

CFD ANALYSIS AND HEAT TRANSFER CHARACTERISTICS OF FINNED TUBE HEAT EXCHANGERS

¹ Máté PETRIK*, ² Gábor SZEPESI, ³ Károly JÁRMAI

^{1,2,3} Institute of Energy Engineering and Chemical Machinery, Faculty of Mechanical Engineering and Informatics, University of Miskolc, H-3515, Miskolc-Egyetemváros, Hungary
e-mail: ¹vegypet@uni-miskolc.hu, ²szepesi@uni-miskolc.hu
³jarmai@uni-miskolc.hu

Received 29 December 2018; accepted 17 May 2019

Abstract: The aim of the paper is to fulfill the parametric analysis on the heating performance of a compact automotive radiator using computational fluid dynamics. The analysis has been carried out at different air velocities with different fins modeling as real fins and as porous media. SC-Tetra computational fluid dynamics software was used for this study. The fluids are incompressible; the flow was three-dimensional and turbulent. The geometry of the fins has a high impact to the heat transfer coefficient and the heat performance, so the shape, the size and the thickness of the fins are compared to each other. The results show that the ratio of the fin pitch, the wall thickness of the fins, the number of the fins, the flow depth and the geometry of the tube are the main factors of the heat transfer. The main goal is to find a dependable Nu-number correlation for this type of heat exchanger. Furthermore with the usage of this function the goal is to find the optimal shape of the radiator, which can decrease the temperature of the cooling liquid to the necessary value and has the smallest weight.

Keywords: Finned tube heat exchanger, Computational fluid dynamics analysis, Heat transfer

1. Introduction

Finned tube heat exchangers are one of the numerous types of heat transfer equipment. With this heat exchanger type the thermal performance can be improved due to the high heat transfer area, but the fins acting like resistance will cause a lower heat transfer coefficient on the air side. Despite of this fact, these devices are commonly used in the air cooling systems, the vehicle industry as an automotive radiator and also in the

* Corresponding Author

household as radiators. Risberg et al. [1], Liping and Wong [2] and Awbi [3] made investigation about the convective heat transfer from household radiators, Wiriyasart and Naphon [4] made investigations about whole workshops. Oliet et al. [5] and Astrouski et al. [6] dealt especially automotive radiators. In the above cases, radiators are the main part of the engine cooling system. The cooling fluid circulates in a pipeline between the engine and the radiator. The material of the fins has also a significant effect to the heat transfer coefficient. In the engine the fluid takes up the heat of the combustion, while in the radiator it sends this heat to the flowing air. Musat and Helerea [7] combined the previous cases: they investigated a Passengers Thermal Comfort (PTC) heater in a vehicle. This heat exchanger is a secondary part of the engine cooling system and used for heating the inner of the car.

These finned tube heat exchangers have also importance in condensation and evaporation systems (Qiu et al. [8], Chen et al. [9]). The latest researchers deal with non-traditional type of ribs, for example micro-fin structure (Wang et al. [10]) or scaly fin pattern (Chen et al. [11]). These types of fins can increase the heat transfer coefficient in every type of heat exchanger equipment, for example in case of scraped surface devices (Varga et al. [12]).

The selection of the right geometric parameters is essential for the engine. If these geometric dimensions are small, the heat performance of the radiator will be not enough, and the engine will overheat. However, in case of an oversized radiator, the mass will be too high, and this will cause higher fuel consumption. This fact does not affect to the conventional gasoline engine, but there is a significant effect for the electric vehicle and planes. In both cases the maximum range will be decreasing. It means that in case of an optimal sizing of the air cooler there is no need fan to achieve a higher air velocity, because the velocity of the vehicle is enough for the necessary heat performance. That means that the fans do not have electrical consumption demand.

In practice and of course in literature there are a lot of finned tube geometries. As in all cases of heat convection the heat transfer coefficient is calculated by empirical correlations. In external forced convection, the Nu-number correlation depends on the shape of the geometry (plane, tubular, rectangular, sphere), the material properties in the medium temperature and the velocity of the fluid. The extended surface will induce turbulent mixing but it will increase the resistance too. The heat transfer between the flowing air and the cooling fluid is definitely different compared to the cases without fin (Bolló [13]).

Numerous studies deal with the effect of the different type of fins to investigate the heat transfer characteristics. Markovic et al. [14] and Jang et al. [15] dealt with three-dimensional plate fin and tube heat exchangers, and made simulations for in-lined and staggered arrangements, which is shown in *Fig. 1*.

They made measurements and simulations for a heat exchanger and showed up that the staggered arrangement is more favorable, because there is a smaller recirculation zone behind the tubes, while the in-line arrangement will cause a dead flow zone, which results a lower heat transfer coefficient. Due to this fact the pressure drop of the finned tube has a higher value, than the staggered arrangement.

The other main type of fins is the louver fins. At this case the fins are between the tubes. That means these fins are warmer from two ways. For louver fin having flat and circular tube configurations, extended experimental data were reported by Chang et al.

[16], Achaichia et al. [17] and Leu et al. [18]. The schematic drawing of the investigated oval tube with fin patterns is shown in *Fig. 2*.

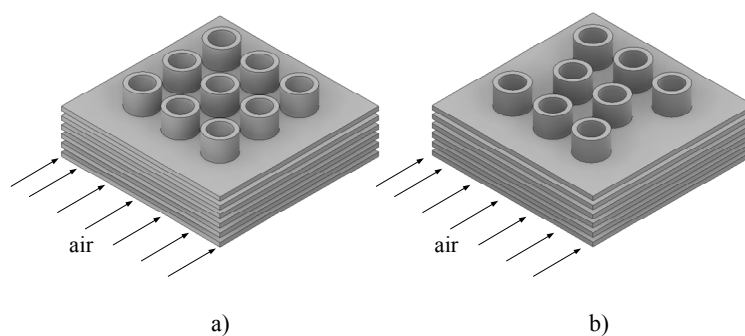

Fig. 1. In-line and staggered tube arrangement

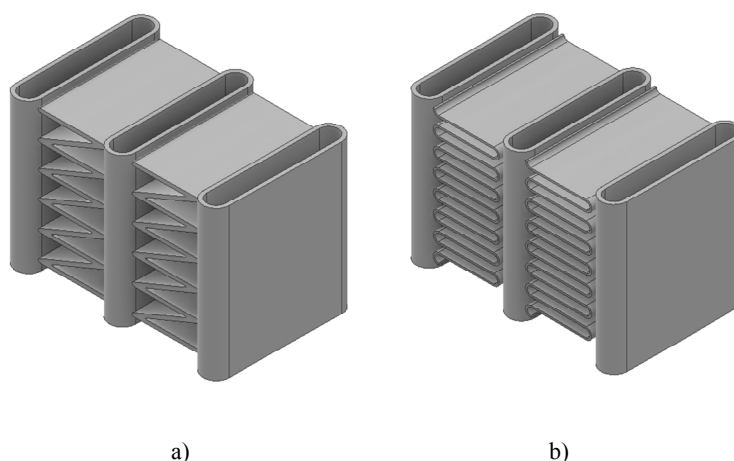

Fig. 2. Louver fin with a) triangular channel and b) rectangular channel

In these studies, lots of louver finned heat exchangers are investigated by regression analysis. They showed that there is no commonly used empirical correlation, but for a given geometry, between narrow ranges there are well used experimental correlations.

Not only the arrangement and shape of the tube have a significant effect to the heat performance, but the shape of the fins also. In an ordinary automotive radiator, the fins are radial to the tubes. That means the heat energy is transferred from the heated cooling liquid into the air. The heat energy is transferred by a complex process: convection inside the tube and outside the fins and by conduction through the fins. The different fin shapes show different behavior. Ereğ et al. [19] investigated the effect of the location of the fin tube center, fin height, distance between the fins, and tube thickness and tube ellipticity on the heat transfer coefficient and pressure drop.

2. Modeling and simulation

2.1. Types of simulations

To investigate a finned tube heat exchange with Computational Fluid Dynamics (CFD) software, there are two different simulation methods: fins modeled as real, physical fins and modeled as porous media. The goal of this study is to compare the two methods with a relatively simple geometry for complex structures, and it can be tested relatively quickly in the future. In case of real fin model, the fins around the tube are physically modeled in the geometry. Advantages of this method are that the model is closer to reality, but disadvantages are the large number of required elements and high running time. *Fig. 3* shows the 3D view of the investigated finned tube.

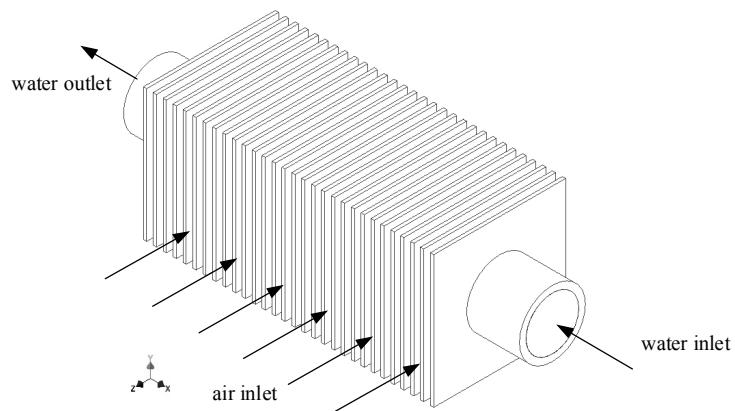

Fig. 3. Physical fin model

The simulated fins were rectangular shape with 20 mm height, 20 mm width and 0.5 mm thickness, and made from aluminum. The inner diameter of the tube was 8 mm, the outer was 10 mm and made from aluminum too. *Fig. 4* shows the schematic drawing of the finned tube and *Table I* shows the specified geometry.

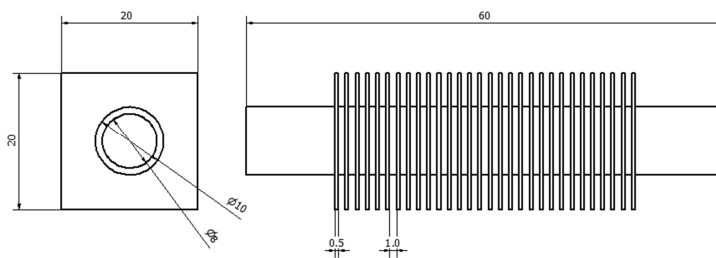

Fig. 4. Finned tube with real sizes

Table I

Dimensions of the simulated finned tube

Geometry	Parameter	Value-unit
Width of fins	W	20 mm
Height of fins	H	20 mm
Thickness of fins	t	0,5 mm
Distance of fins	s	1 mm
Outer diameter of tube	D_o	10 mm
Inner diameter of tube	D_i	8 mm
Numbers of fins	n_b	30
Length of tube	L	60 mm
Total heat transfer area	A_{total}	0.01049 m ²
Heat transfer area of tube	A_{tube}	0.0011 m ²

In contrast the porous media model the drawing of each fin is not necessary, as it is shown in Fig. 5. The geometry and material of the fins are set up into the porous media, and the interaction between the solid fins and flowing fluids is computed by the CFD solver.

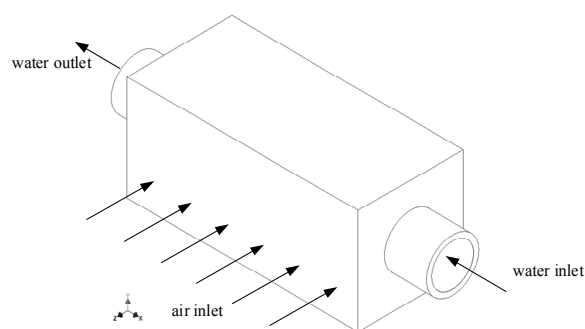

Fig. 5. Porous media model

2.2. Boundary conditions

The ambient air modeled as air with buoyancy, material properties belongs to 20 °C temperature; the gravity is the $-y$ direction. The air flow is considered to be one dimensional, and it flows in the direction of the z axis with velocity of 8 m/s. The radiative heat transfer is neglected at these simulations. The air flow simulated in a rectangular body, and its further four sides have been set up as adiabatic wall.

The coolant fluid is modeled as incompressible water, and its properties also have been set up at 20 °C. This fluid flows normal to the air, in the direction of the x axis, and its velocity is 0.2 m/s. For both fluids, the outlet boundary conditions were static pressure conditions, and all the inlets and outlets the inflow turbulence property was assumed 0.0001 m²/s². The models were simulated with SC-Tetra CFD software. The used turbulence model was the realizable $k-\varepsilon$ and Semi IMPLICIT Linked Equations

Consistent (SIMPLEC) method was used for pressure correction (with further investigations the different turbulence models will be compare to each other).

2.3. Used mesh and results

For the comparison the first simulation has been evaluated with the physical fin model. During the meshing process, the so-called prism layer must be determined in all solid-liquid/air connecting surface. The thickness of this prism layer, 10^{-4} m has been set up in three layers with a 1.1 variable rate of the thickness. For a smoother mesh, hexahedral element types were used. *Fig. 6* shows a mesh section of the physical fin model. With these settings the number of elements was 9.8 million. The calculation time was 2 hours and 45 minutes, and the steady-state condition was satisfied after 162 cycles. At this case, the region averaged temperature of the outlet air was 23.08 °C, while the outlet water was 57.8 °C.

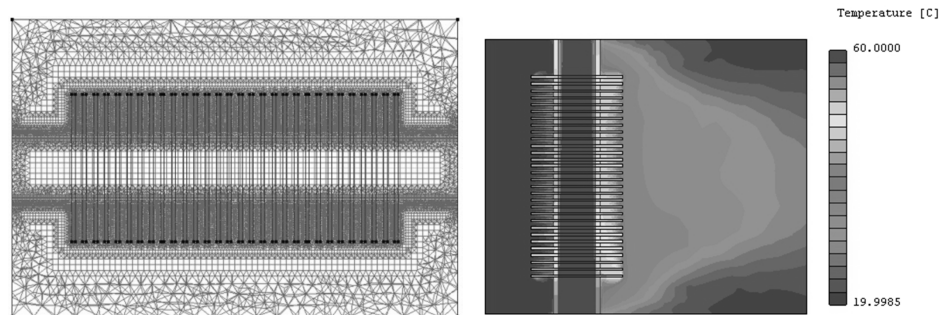

Fig. 6. Used mesh of the physical model (left) and temperature distribution (right)

With the usage of the porous media model, the reduction of the computational time and performance would like to be achieved. In this case the prism layer has been set up to the inner and outer wall of the tube. A relatively high disadvantage of this simulation method is the assumption of the temperature around the fins. In this case, this temperature has been set up at 20 °C, but in the reality in this volume this temperature changes from point to point. With these considerations, smaller mesh was created with a number of elements of 1.465 million. The calculation time was only 35 minutes and it reached a steady state after 299 iterations. *Fig. 7* shows the used mesh and the temperature distribution of the porous media model.

The values of the regional averaged temperatures are 22.33 °C for the air outlet surface and 58.18 °C for the water outlet. The differences in the real fin model are 3.35% for air side and 0.34% of the water side, which are fairly accurate values.

After that step for mesh independence test, a mesh refinement has been executed with a refinement. That causes a mesh with 8.37 million elements. This number is also smaller value than the model with the real fins, so even more exact match was expected. But even this smoother mesh, the simulation does not reach the steady state statement after 850 iterations. Even though it did not converge, the temperatures are available. The temperature of the outlet air is 22.74 °C and the water is 58.00 °C. These values are

closer to the real fin model than the small porous model, but the calculation time was 4 hours and 43 minutes, which is the worst of the three cases, and this fact due to the number of iterations and total number of elements. The temperature distribution of this simulation is shown in *Fig. 8*.

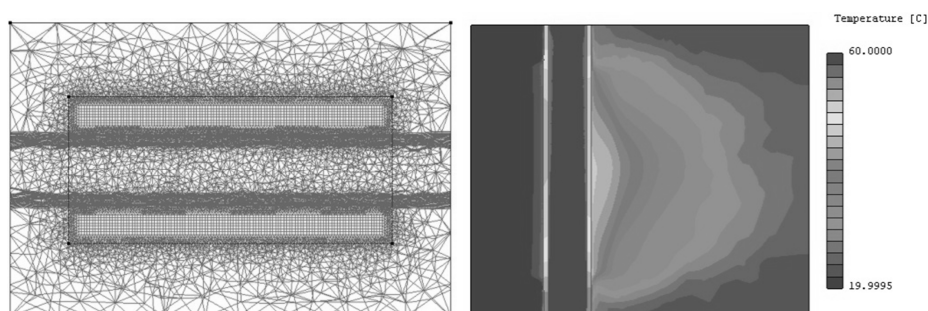

Fig. 7. Used mesh of the porous media model (left) and temperature distribution (right)

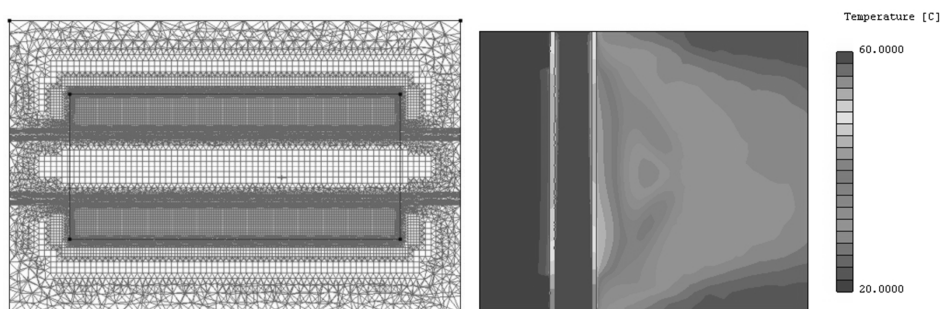

Fig. 8. Used mesh of the porous media model (left) and temperature distribution (right) for the finer mesh

3. Comparison of the CFD results with analytical results

To determine the heat transfer coefficients to the tube side and the air side, empirical Nu-number correlations are used from Cengel's results [20]. To compare the three different simulations, three analytical calculations have been realized/evaluated using the outlet temperatures.

3.1. Calculations of the tube side

The flow of the cooling fluid is a simple internal flow in a circular tube. The used empirical correlation depends only on the Re-number. Despite of the small differences between the simulated results, the calculated condition numbers and heat transfer coefficient are the same. In this case, the inner diameter (D_i) is 8 mm, the Reynolds number is

$$Re_w = \frac{v_w \cdot D_i \cdot \rho_w}{\eta_w} = 3355.068, \quad (1)$$

that means that the flow is in the transient zone. The applied Nu-number correlation is:

$$Nu_w = 0.008 \cdot Re_w^{0.9} \cdot Pr_w^{0.43} = 19.149, \quad (2)$$

where the Pr-number is 3.012. From this, the individual heat transfer coefficient is

$$\alpha_w = \frac{Nu_w \cdot \lambda_w}{D_i} = 1560.2 \frac{\text{W}}{\text{m}^2\text{K}}, \quad (3)$$

where v_w the velocity of the cooling fluid [m/s]; ρ_w is the density [kg/m^3]; η_w the dynamic viscosity [Pa·s]; λ_w the heat conductivity [W/(m·K)] and Pr_w is the Prandtl number [-] of the cooling fluid; α_w is the calculated heat transfer coefficient [W/(m²·K)] to the tube side.

3.2. Calculations of the air side

To determine the heat transfer coefficient in the air side, the effect of the fins needs to be considered. The fin and tube system assumed as a vertical plate for the empirical correlation. The characteristic length is the height of the fins for all condition equation:

$$Re_a = \frac{v_a \cdot H \cdot \rho_a}{\eta_a} = 10621.49. \quad (4)$$

The change of the material properties is also neglected. The Pr-number for the air is 0.708. Using the empirical correlation for this geometry:

$$Nu_a = 0.228 \cdot Re_a^{0.731} \cdot Pr_a^{0.33} = 178.31, \quad (5)$$

where v_a the velocity of the ambient air [m/s]; ρ_a is the density [kg/m^3]; η_a the dynamic viscosity [Pa·s]; λ_a the heat conductivity [W/(m·K)] and Pr_a is the Prandtl number [-] of the air, and H is the height of the fins [m].

This means a 229.207 W/(m²K) heat transfer coefficient, but this value must be corrected with the fin efficiency. For determining this trait, firstly a fin parameter must be calculated, which is the function of the geometry, the heat conduction and the convection:

$$\zeta_f = \left(\frac{W - D_o}{2} + \frac{t_f}{2} \right) \cdot \sqrt{\frac{\alpha_a}{\lambda_f \cdot t_f}} = 0.245, \quad (6)$$

where W is the width of fins [m]; D_o is the outside diameter of the tube [m]; t_f is the thickness of fins; λ_f is the heat conductivity of the fins [W/(m·K)] and α_a is the heat transfer coefficient to the air side [W/(m²·K)].

The fin efficiency comes from a graph, but easy the calculations, polynomial function created:

$$\eta_f = 0.0427 \cdot \zeta_f^5 - 0.3077 \cdot \zeta_f^4 + 0.7902 \cdot \zeta_f^3 - 0.7155 \cdot \zeta_f^2 - 0.3572 \cdot \zeta_f + 1.0005 = 0.8804 \quad (7)$$

This will cause a 201.79 W/(m²K) heat transfer coefficient on the air side.

3.3. Calculations of the heat exchanger

To determine the overall heat transfer coefficient, the ratio of the surfaces should be calculated in the correlation:

$$k = \frac{1}{\frac{1}{\alpha_a} + \frac{A_{total}}{A_{tube}} \cdot \frac{\lambda_{tube}}{S_{tube}} + \frac{1}{\alpha_w}} = 90.1 \frac{\text{W}}{\text{m}^2 \cdot \text{K}} \quad (8)$$

The total heat transfer area is shown in *Table I*, and its value is 0.010498 m². The last step is specifying the logarithmic mean temperature difference. For this step, the results of the real fin tube simulation are used. This means the higher temperature difference is

$$\Delta T_b = T_{w,i} - T_{a,0} = 37.98 \text{ }^\circ\text{C} \quad (9)$$

$$\Delta T_s = T_{w,o} - T_{a,i} = 36.92 \text{ }^\circ\text{C} \quad (10)$$

The logarithmic mean temperature difference is

$$\Delta T_{LOG} = \frac{\Delta T_b - \Delta T_s}{\ln \frac{\Delta T_b}{\Delta T_s}} = 37.45 \text{ }^\circ\text{C} \quad (11)$$

Since the air flows perpendicular to the heat exchanger, the logarithmic mean temperature difference can be calculated as counter current. From these, the calculated heat performance is

$$\dot{Q}_{he} = k \cdot A_{total} \cdot \Delta T_{LOG} = 35.41 \text{ W} \quad (12)$$

while the amount of heat from cooling the water is shown in *Table II* for the three models:

Table II
Heat performances of the numerical simulations

Physical fin model	Porous model	Finer porous model
83.61 W	75.33 W	82.78 W

These results show that the used empirical correlation with the air side is inappropriate in every case. Making multiple calculations with different experiential relationships (assuming the finned tube as a square cross section, elliptical cross section), the results show the featured presumption is closest to the reality. The difference between the analytical and numerical results induces even more numerical simulations and measurements to find an experimental relationship that approximates the heat transfer relationships of the examined geometry.

4. Conclusion and future work

Two different numerical modeling opportunities are presented in this paper. A 60 mm long circular tube with 30 pieces, rectangular shaped fins with 0.5 mm thickness is modeled as physical fins and as porous media. The numerical simulations were performed by SC-Tetra CFD software. The results show that physical fin model is acceptable, but in case of a more complicated geometry, the number of elements will exponentially be increasing, what will increase the calculation time. The porous media model is a useful alternative, when the simulated heat exchanger has a lot of very thin fins (for example an automotive heat exchanger). In this case, the number of elements is eighth of the original one, while the differences between the results are above than 3.5%. The result of the analytical calculation showed a higher difference to the simulations. In the near future, measurements will be carried out in a wind tunnel with different finned tubes to determine the heat transfer coefficient on the air side. This correlation will be very useful when designing industrial air coolers and automotive radiators.

Acknowledgements

The research work is supported by the ÚNKP-18-3 New National Excellence program of the Ministry of Human Capacities.



Open Access statement

This is an open-access article distributed under the terms of the Creative Commons Attribution 4.0 International License (<https://creativecommons.org/licenses/by/4.0/>), which permits unrestricted use, distribution, and reproduction in any medium, provided the original author and source are credited, a link to the CC License is provided, and changes - if any - are indicated. (SID_1)

References

- [1] Risberg D., Risberg M., and Westerlund L. CFD modeling of radiators in buildings with user-defined wall functions, *Appl. Therm. Eng.*, Vol. 94, 2016, pp. 266–273.
- [2] Wang L. Wong N. H. Coupled simulations for naturally ventilated rooms between building simulation (BS) and computational fluid dynamics (CFD) for better prediction of indoor thermal environment, *Building and Environment*, Vol. 44, No. 1, 2009, pp. 95–112.
- [3] Awbi H. B. Calculation of convective heat transfer coefficients of room surfaces for natural convection, *Energy Build*, Vol. 28, No. 2, 1998, pp. 219–227.
- [4] Wiriyasart S., Naphon P. Numerical study on air ventilation in the workshop room with multiple heat sources, *Case Stud. Therm. Eng.*, Vol. 13, 2019, paper. 100405.
- [5] Oliet C., Oliva A., Castro J., Pérez-Segarra C. D. Parametric studies on automotive radiators, *Appl. Therm. Eng.*, Vol. 27, No. 11-12, 2007, pp. 2033–2043.
- [6] Astrouski I., Raudensky M., Krásny I. Polymeric hollow fiber heat exchanger as an automotive radiator, *Appl. Therm. Eng.*, Vol. 108, 2016, pp. 798–803.
- [7] Musat R., Helerea E. Modeling and simulation of the ptc heater used in automotive, *Pollack Periodica*, Vol. 5, No. 2, 2010, pp. 107–118.
- [8] Qiu G., Sun J., Ma Y., Qu J., Cai W. Theoretical study on the heat transfer characteristics of a plain fin in the finned-tube evaporator assisted by solar energy, *Int. J. Heat Mass Transf.*, Vol. 127, Part B, 2018, pp. 847–855.
- [9] Chen J., Zhang J., Ma Z. Falling film mode transitions on horizontal enhanced tubes with two-dimensional integral fins: Effect of tube spacing and fin structures, *Exp. Therm. Fluid Sci.*, Vol. 101, 2019, pp. 241–250.
- [10] Wang D., Tian R., Zhang Y., Li L. L., Shi L. Experimental comparison of the heat transfer of supercritical R134a in a micro-fin tube and a smooth tube, *Int. J. Heat Mass Transf.*, Vol. 129, 2019, pp. 1194–1205.
- [11] Chen Z. Y., Cheng M., Liao Q., Ding Y. D., Zhang J. N. Experimental investigation on the air-side flow and heat transfer characteristics of 3-D finned tube bundle, *Int. J. Heat Mass Transf.*, Vol. 131, 2019, pp. 506–516.
- [12] Varga T., Szepesi G., Siménfalvi Z. Horizontal scraped surface heat exchanger - Experimental measurements and numerical analysis, *Pollack Periodica*, Vol. 12, No. 1, 2017, pp. 107–122.
- [13] Bolló B. Low reynolds number flow around and heat transfer from a heated circular cylinder, *Int. Rev. Appl. Sci. and Eng.*, Vol. 1, No. 1–2, 2010, pp. 15–20.
- [14] Marković S., Jaćimović B., Genić S., Mihailović M., Milovančević U., Otović M. Air side pressure drop in plate finned tube heat exchangers, *Int. J. Refrig.*, Vol. 99, 2019, pp. 24–29.
- [15] Jang J. Y., Wu M. C., Chang W. J. Numerical and experimental studies of threedimensional plate-fin and tube heat exchangers, *Int. J. Heat Mass Transf.*, Vol. 39, No. 14, 1996, pp. 3057–3066.
- [16] Chang Y. J., Wang C. C. A generalized heat transfer correlation for louver fin geometry, *Int. J. Heat Mass Transf.*, Vol. 40, No. 3, 1997, pp. 533–544.

- [17] Achaichia A., Cowell T. A. Heat transfer and pressure drop characteristics of flat tube and louvered plate fin surfaces, *Exp. Therm. Fluid Sci*, Vol. 1, No. 2, 1988, pp. 147–157.
- [18] Leu J. S., Liu M. S., Liaw J. S., Wang C. C. A numerical investigation of louvered fin-and-tube heat exchangers having circular and oval tube configurations, *Int. J. Heat Mass Transf*, Vol. 44, No. 22, 2001, pp. 4235–4243.
- [19] Ereğ A., Özerdem B., Bilir L., İlken Z. Effect of geometrical parameters on heat transfer and pressure drop characteristics of plate fin and tube heat exchangers, *Appl. Therm. Eng*, Vol. 25, No. 14–15, 2005, pp. 2421–2431.
- [20] Çengel Y. A. *Heat transfer - A practical approach*, 2nd Edition, McGraw-Hill, 2002.