



---

## DEVELOPMENT OF 3D PRINTING RAW MATERIALS FROM PLASTIC WASTE

**Author(s):**

A. Oussai, L. Katai and Z. Bártfai

**Affiliation:**

Szent István University, Faculty of Mechanical Engineering Institute of Mechanics and Machinery  
Szent István University, Páter K. u. 1., Gödöllő, H-2100 Hungary

**Email address:**

alaoussai@gmail.com

---

**Abstract:** Having studied the applied plastic recycling technologies, materials for 3D printing and the 3D printing technologies it is realized that the quantity and quality of plastic waste differs from country to country and from company to other, PET is recycled quite frequently and has the number "1" as its recycling symbol, and after drying PET prepared for extrusion, then material is shredded and dried, its ready to be extruded. The 'Next filament extruder' was used for the extrusion of PET (shredded format), with 3 different diameters of shredded material and constant range of temperature heater and speed of fan speed, the measurement can be ready after 3 or maximum 5 tests. After testing and measuring with different diameters, making filament from shredded PET will work better if it's made with a diameter of 1.75mm which means a thicker diameter is used, the filament will probably collapse under its own weight, causing the filament to swirl and jam in the filament sensor.

**Keywords:** recycling, 3D printing, plastic, waste management

### 1. Introduction

Having studied the applied plastic recycling technologies, materials for 3D printing and the 3D printing technologies it is realized that the quantity and quality of plastic waste differs from country to country and from company to other. In the case of waste plastics that are recyclable and reusable, the most widely used are polyethylene terephthalate (PET, used for synthetic fibres and water bottles), and second high-density polyethylene (HDPE, used for jugs, bottle caps, water pipes).

The current applications for using recycled plastics in fabrication and design are fairly limited, on a small scale, plastics (such as ABS, HDPE, or PET) are shredded and formed into pellets, and then either extruded into filament to be used in existing 3D printers, or injection moulded into small parts and pieces of larger components. At a large scale, recycled HDPE is melted into sheets and either used directly as sheets in construction, or then heat formed from a sheet into components for construction. These methods of fabrication using recycled plastics are the norm because of their affordability and straightforward processes, yet each method leaves some complexity to be desired.[1].

Regarding the recycling technology, the previous methods of recycling and recovery routes for solid plastic waste are detailed and discussed covering:

- re-extrusion
- mechanical treatment
- chemical treatment
- energy recovery

Based on the previous research I performed on this field, the main objective of my project is the contribution to the development of sustainable, effective technologies on the field of plastic recycling, both from the economic and ecological point of view

## 2. Methods and materials

Recycling technology: PET plastic waste aggregate was prepared by grinding waste PET plastic bottles. The preparation process of PET plastic waste aggregate includes the following steps:

- Collecting the PET bottles wastes.
- Removing the cover and trade label.
- Washing and drying the bottles.
- Shredding and grinding the PET bottles to the specified particle size

The grinding process was carried out in the FKF ZRT. (see in Fig. 1):



Figure 1. PET plastic recycling steps

Contacting FKF.ZRT which is recycling company of plastic in Budapest, they provide a table, that shows the types and the ratio of the collected selective waste from the last year. These numbers are based on their monthly sorting.

By selecting few months from all year, it shows the importance and the highest quantity of clean, blue or coloured PET which the main material for the research.

Table 1. Types and ratio of the collected selective waste during 2018

2018		January		February		March	
		Kg	m/m%	Kg	m/m%	Kg	m/m%
PET	Clean	30,4	12,2	27,0	10,6	30,2	11,9
	Blue	38,5	15,4	30,4	11,9	32,6	12,8
	Coloured	10,9	4,4	16,0	6,3	18,9	7,4
Foil	Dyed	6,3	2,5	8,6	3,4	5,6	2,2
	Natural	4,1	1,6	7,3	2,9	5,0	2,0
Flacon		36,5	14,6	25,4	10,0	22,4	8,8
Hungarocell		0,3	0,1	1,0	0,4	1,4	0,6
Metal	Tinned metal	6,0	2,4	6,2	2,4	3,0	1,2
	Aluminium	6,1	2,4	6,4	2,5	3,3	1,3
Other Waste		111,1	44,4	126,3	49,6	131,8	51,8
Altogether		250,2	100,0	254,6	100,0	254,2	100,0
Recyclable		138,8	55,5	127,3	50,0	121,0	47,6
Non-Recyclable		111,4	44,5	127,3	50,0	133,2	52,4

The main production for PET is for the applicability of synthetic fibres (in excess of 60%) with bottle production accounting for around 30% of global demand. In terms of textile applications, PET is generally referred to as simply "polyester". The terminology "PET" is used generally for packaging applications. The polyester industry makes up about 18% of world polymer production and is third largest industry after polyethylene (PE) and polypropylene (PP). [2].

PET is recycled quite frequently and has the number "1" as its recycling symbol. The first PET was patented in 1941 by John Rex Winfield, James Tennant Dickson and their employer the Calico Printers' Association of Manchester and the PET bottle was patented in 1973 by Nathaniel Wyeth. PET is also used as substrate in thin film and solar cell.[3].

Table 2. Thermal properties for PET

Material	Polyethylene Terephthalate
Melting point [°C].	225
Drying time [hours]	4-5
Drying temperature [°C]	160

Some tests will be provided in laboratory of mechanical engineering in Szent Istvan University, probably around 3 to 5 measurement.

First drying PET prepared for extrusion, after the material is shredded and dried, its ready to be extruded. The 'Next filament extruder' was used for the extrusion of PET (shredded format).



Figure 2. Example of extrusion machine

Three tests will be done with different diameter of shredded material

With 3 different diameters of shredded material and constant range of temperature heater and speed of fan speed, our measurement can be ready after 3 or maximum 5 tests. Table 3 shows the settings used for every test.

Filaments product for 3D printing: The following materials were used in this research:

–recycled polyethylene terephthalate (rPET), supplied by FKF ZRT

–polyethylene terephthalate (PET).

For the test, it starts by filament quality control contain the measurement of diameter of recycled polyethylene terephthalate and the filament in interval of 1 meter, after will be test the surfaces and cross section of the materials and then find the melting point which shows the thermal properties. Second test will be tensile testing for raw materials

Table.3 Setting and parameters using during the test

TEST	Diameter of shredded material(mm)	Temperature range[°C]	Filament fan speed (%) and extruder(rpm)
1	2,85	240-245	80-5
2	2	240-245	80-5
3	1,75	240-245	80-5

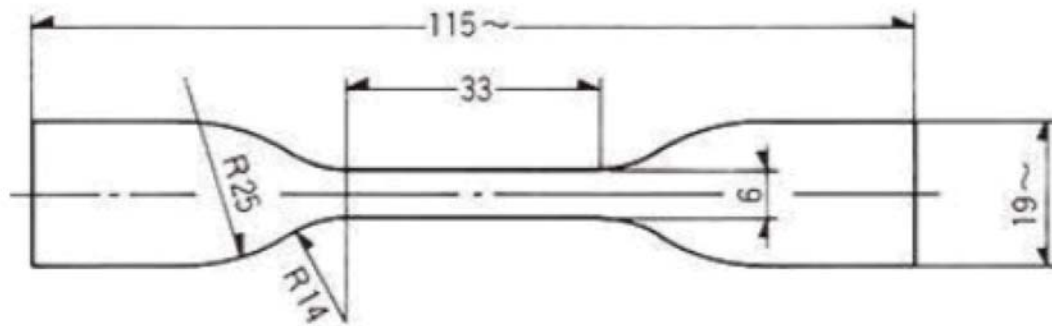

Figure 3. Sample type of tensile testing

Tensile testing was performed by using a material testing machine, Testometric M 350- 5CT see Figure 4 (faculty of mechanical engineering SZIE).



Figure 4. Material testing machine, Testometric

### 3. Results

Recycling technology: Recent research points the way towards chemical recycling methods with lower energy requirements, compatibilization of mixed plastic wastes to avoid the need for sorting, and expanding recycling technologies to traditionally non-recyclable polymers. We mentioned the recycling technologies from which we concluded that mechanical recycling is the only widely adopted technology for large-scale treatment of plastic solid waste. The main steps were the removal of organic residue through washing, followed by shredding, melting, and remoulding of the polymer, which is often blended with virgin plastic of the same type to produce a material with suitable properties for manufacturing. In my previous research supervised by Dr Zoltán Bártfai, It found solution for grinding and extruding plastic using machines with two different parts: crusher, extruder and mixed it together.

The crusher consisted of 12 blades twelve anvil-blades, right axis, left axis, cover, sieve, fourteen casing spacers, four nuts, two pins and crank. [4].

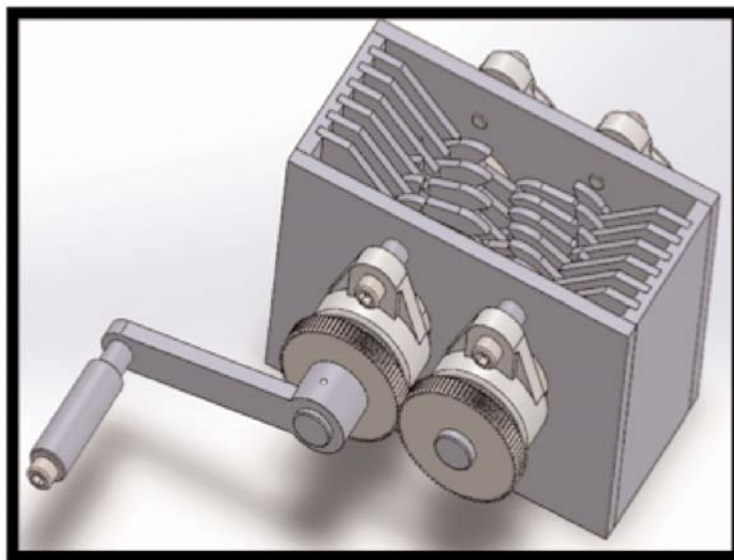

Figure 5. Overview of the complete design of the crusher

Current technologies that move beyond mechanical recycling include pyrolysis (thermolysis) to selectively produce gases, fuels, or waxes through the use of catalysts; are referred to as chemical recycling. Chemical recycling is not a widespread recycling practice, mainly because of energy costs. A further option is the incineration of materials and collection of energy in the form of heat. Incineration is convenient for the treatment of mixed waste because it avoids the need for sorting, but it does not allow for the recovery and reuse of the starting components once burned. It also does not save as much energy as recycling.

Filament product for 3D printers: Within the frame of this research project, performing adequate laboratory test processes we are going to cooperate with the FKF ZRT. This company works in a strong connection with the faculty of mechanical Engineering. They have well equipped laboratory for testing recycled plastic waste.

Previous test show that conductive anti-static ABS has advantages with excellent mechanical strength, impact resistance, dimensional stability, high flow creep resistance and excellent heat and low temperature resistance.

Several trial tests were run but optimal conditions for the rPE extrusion process were not found. The outcome of rPE filament was good. PET filament was better. The main problem during rPET extrusion is the stoppage of the material flow.

In the middle of the extrusion, extrudate stopped coming out of the die that caused rHDPE filament to thin out and eventually to break. Pristine HDPE extrusion went without any complications.



*Figure 6.* Produced filament from PET

## Conclusions

The aim is to test if normal plastic bottles can be turned into 3D printing filament. The following is a quick summary of our tests to turn around 30 bottles into filament. Water bottles were collected, cleaned (properly) and any external caps or seals were also removed, the bottles were then vacuum sealed and heated to reduce their size, once cooled the bottles were cut into smaller chunks with a saw and a pair of scissors, after that, the pieces were shredded into tiny pieces, the pieces were then dried at a temperature of 160°C for 4 hours, The PET was then fed into next filament extruder, after multiple tests at different nozzle diameters and temperatures, our team ended up with a great result of PET filament, Recently, the US Department of Defence (DoD) is exploring 3D printing feedstock made from plastic containers that have been left on the battlefield, which can hopefully be reproduced in other government sectors. There's also Ethical Filament, a company focused on promoting the concept of recycling to produce ethical 3D printing filament that is sold to improve the livelihoods of waste pickers and their communities worldwide. Then there's the Perpetual Plastic Project (PPP), which is an installation which can directly recycle old plastic drinking cups into 3D printing gadgets as well as other plastic products if needed.

While there is more and more aware of using recycled filament for 3D printing, we still have a long way to go. Hopefully, with the rise in 3D printing over the last few years, more emphasis is being placed on plastic recycling.

## Nomenclature

PET: PolyEthylene Terephthalate

ABS: Acrylonitrile butadiene styrene

PLA: Polylactic acid

rPET: Recycled polyethylene terephthalate

FKF: Public service company owned by the Municipality of Budapest.

PE: Polyethylene

HDPE: High density polyethylene

MPa: pressure measured in megapascal

## References

- [1] Albano, C., Camacho, N., Hernández, M., Matheus, A., & Gutiérrez, A. (2009). Influence of content and particle size of waste pet bottles on concrete behavior at different w/c ratios. *Waste Management*, 29(10), 2707–2716. <https://doi.org/10.1016/J.WASMAN.2009.05.007>

- [2] **Al-Salem, S. M., Lettieri, P., & Baeyens, J.** (2009). Recycling and recovery routes of plastic solid waste (PSW): A review. *Waste Management*, 29(10), 2625–2643. <https://doi.org/10.1016/J.WASMAN.2009.06.004>
- [3] **Bornak, R.** (2013). Different Methods of PET Production and Its Economy Different Methods of PET Production and Its Economy. *European Journal of Scientific Research*, (December), 2–3.
- [4] **Choi, Y.-W., Moon, D.-J., Chung, J.-S., & Cho, S.-K.** (2005). Effects of waste PET bottles aggregate on the properties of concrete. *Cement and Concrete Research*, 35(4), 776–781. <https://doi.org/10.1016/J.CEMCONRES.2004.05.014>
- [5] **Frigione, M.** (2010). Recycling of PET bottles as fine aggregate in concrete. *Waste Management*, 30(6), 1101–1106. <https://doi.org/10.1016/J.WASMAN.2010.01.030>
- [6] **Hannawi, K., Kamali-Bernard, S., & Prince, W.** (2010). Physical and mechanical properties of mortars containing PET and PC waste aggregates. *Waste Management*, 30(11), 2312–2320. <https://doi.org/10.1016/J.WASMAN.2010.03.028>
- [7] **Hopewell, J., Dvorak, R., & Kosior, E.** (2009). Plastics recycling: challenges and opportunities. *Philosophical Transactions of the Royal Society B: Biological Sciences*, 364(1), 2115–2126. <https://doi.org/10.1098/rstb.2008.0311>
- [8] **Ismail, Z. Z., & AL-Hashmi, E. A.** (2008). Use of waste plastic in concrete mixture as aggregate replacement. *Waste Management*, 28(11), 2041–2047. <https://doi.org/10.1016/J.WASMAN.2007.08.023>