



Improving the ductility and heat deflection temperature of injection molded Poly(lactic acid) products: A comprehensive review

Tamás Tábi^{a,b,*}, Tatyana Ageyeva^{a,c}, József Gábor Kovács^{a,c}

^a Department of Polymer Engineering, Faculty of Mechanical Engineering, Budapest University of Technology and Economics, Műgyetem rkp. 3., H-1111, Budapest, Hungary

^b MTA-BME Research Group for Composite Science and Technology, Műgyetem rkp. 3., H-1111, Budapest, Hungary

^c MTA-BME Lendület Lightweight Polymer Composites Research Group, Műgyetem rkp. 3., H-1111, Budapest, Hungary

ARTICLE INFO

Keywords:

Poly(lactic acid)
Blends
Impact modification
Nucleation
Stereocomplexation
Bio-composites

ABSTRACT

The widely used plastic products which became a part of our everyday life are produced almost entirely from crude oil. There are various estimates on oil resources, but there is an increasing need to use other, preferably renewable resources to produce plastic products. Although plastics from renewable resources, bio-based, and inherently biodegradable plastics, or so-called bioplastics/biopolymers, are already on the market, their properties are not always adequate compared to those of “ordinary” petroleum-based plastics, which the bioplastic is supposed to replace. One of the most promising bioplastics nowadays is Poly(lactic acid) (PLA). Despite the great potential of PLA to replace petroleum-based engineering plastics, such as Acrylonitrile Butadiene Styrene (ABS), Polypropylene (PP), and others, the inherent brittleness and low Heat Deflection Temperature (HDT) hinders the widespread application of PLA. Many methods have been developed to improve the properties of PLA, but its widespread industrial application is still rather an exception than the rule. The current study aims to survey the progress in the modification of the properties of PLA. We focused on the most effective additives to improve the properties of injection molded PLA products, which we selected from a comprehensive literature review. Most of the modification possibilities presented in this review can also be used for other processing technologies, but in the discussion, we focused on their use in injection molding.

1. Introduction

Today biodegradable polymers extracted from biomass attract more and more attention due to requirements of eco-design and sustainable development. Poly(lactic acid) (PLA) is one of the most widely used and studied biodegradable polymers [1–5]. Its annual production reached almost 300,000 tons in 2019, which is approximately 14% of all biodegradable plastics produced [6]. Moreover, it is expected that PLA production will triple in the next few years. The leading role of PLA is ensured by its good mechanical and functional properties, flexible processability, and reasonable cost [1].

PLA can potentially replace Polypropylene (PP), Polyamide (PA), Acrylonitrile Butadiene Styrene (ABS), and some other petroleum-based plastics in various applications [1,7]. Neat PLA exhibits a higher Young's modulus than PP, ABS, or PA (Fig. 1), and its tensile strength is higher than that of PP and ABS but lower than PA. The production of

PLA generates a far smaller carbon dioxide footprint than the production of conventional petroleum-based plastics. The average price of PLA is slightly higher than that of conventional plastics and amounted to 2.1–4.7 USD/kg in 2020 [8]. However, the main drawback of PLA is its inherent brittleness and relatively low Heat Deflection Temperature (HDT) [9].

Its favorable properties make PLA suitable for a broad range of applications. Excellent biocompatibility, together with its high mechanical performance, offers many applications in the medical field (drug delivery systems, orthopedic devices, etc.) [10–12]. High stiffness and transparency, together with flavor and aroma barrier characteristics, make PLA a perfect alternative for packaging [5,13]. Excellent insulation properties accompanied by moisture resistance makes PLA suitable for use in the construction sector [14]. High mechanical performance, together with light weight, should ensure ubiquitous use of PLA in automotive structural parts [15].

* Corresponding author. Department of Polymer Engineering, Faculty of Mechanical Engineering, Budapest University of Technology and Economics, Műgyetem rkp. 3., H-1111, Budapest, Hungary.

E-mail address: tabi@pt.bme.hu (T. Tábi).

<https://doi.org/10.1016/j.polymeresting.2021.107282>

Received 7 April 2021; Received in revised form 22 June 2021; Accepted 25 June 2021

Available online 14 July 2021

0142-9418/© 2021 The Authors.

Published by Elsevier Ltd.

This is an open access article under the CC BY-NC-ND license

(<http://creativecommons.org/licenses/by-nc-nd/4.0/>).

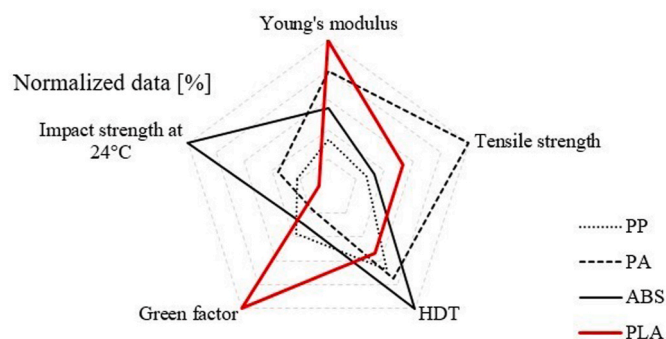

Fig. 1. Comparison of the normalized properties of PLA and conventional petroleum-based polymers (Data are normalized by means of dividing each value by the maximum value in the row; the “green factor” is the inverse value of CO₂ footprint). (For interpretation of the references to colour in this figure legend, the reader is referred to the Web version of this article.)

Nevertheless, the inherent brittleness and low HDT of PLA hinder its widespread application and it is especially challenging to improve both in an injection molded part. At the same time, the properties of PLA can be widely modified by different methods, thus the ductility of PLA can be increased with various plasticizers, impact modifiers, and by blending, co-polymerization, etc., while the HDT of PLA can be improved by increasing crystallinity. Adding bio-based reinforcements and thus producing biocomposites increase the overall mechanical performance of PLA as well as its HDT. Considerable progress in the area of PLA modification has been achieved in the last few decades, which is proved by the increasing number of scientific publications dedicated to the modification of the properties of PLA (Fig. 2).

Although the science community are developing a number of methods to modify the properties of PLA, its widespread use in the industry is still more the exception than the rule. Therefore, this study aims to survey the progress in the field of PLA properties modification and will be useful for the scientific and industrial community. This study covers the following modification methods: plasticizing, the addition of different impact modifiers, blending, copolymerization, nucleation, stereocomplexation, and, finally, the addition of bio-based reinforcement. We focused on presenting the most effective additives and reinforcing agents to enhance the properties of injection molded PLA. At the

same time, most of the modification possibilities and additives (selected from a comprehensive literature review that covers a 20-year timespan) presented are also applicable for other processing technologies as well. In our review, we concentrated on introducing all these literature results from an injection molding processing point of view. Accordingly, the data presented can effectively help engineers bring the properties of PLA closer to those of engineering plastics and thus widen the range of its industrial applications.

2. Synthesis of PLA

PLA is a linear, thermoplastic, and aliphatic polyester. Its monomer, lactic acid (C₃H₆O₃) or also known as 2-hydroxy propionic acid, has one asymmetric carbon atom resulting in two types of stereoisomers (Fig. 3).

Two lactic acid compounds create lactic acid's dimer (with the expulsion of water), which is a cyclic compound named lactide. According to the variety of lactic acid, three types of lactides can be distinguished (Fig. 4).

lactic acid was first isolated by Carl Wilhelm Schele in 1780. It can be found in nature, for example, in intestines (guts) or in the mouth, having a weak fertilization effect, but also in milk or muscle tissues in the case of muscle cramps. Previously, lactic acid was synthesized from petrochemical compounds for a long time but since the 1980s, it has been mass-produced from agricultural plants through fermentation. Nowadays, lactic acid can be entirely produced from renewable resources like starch and thus plants containing glucose (corn, wheat, rice, potato, tapioca, etc.) and from plants containing saccharose (sucrose) (e.g. sugar

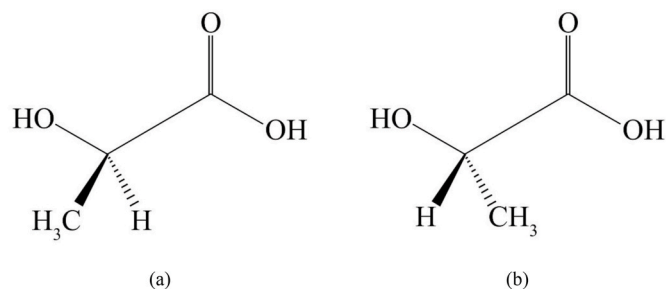

Fig. 3. Stereoisomers of lactic acid: D-lactic acid (a) and L-lactic acid (b).

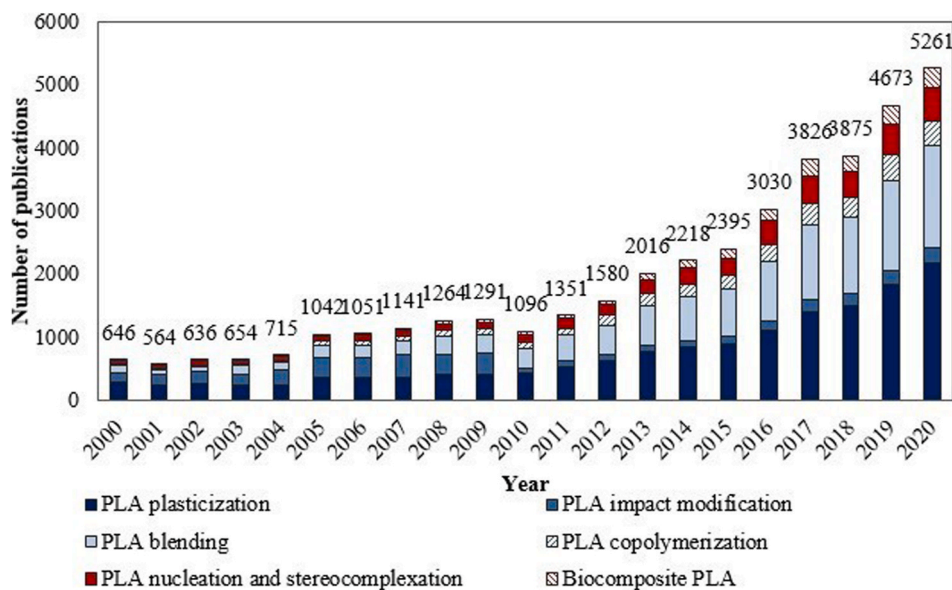

Fig. 2. Number of scientific articles published since 2010 based on the Science Direct search using keywords PLA plasticization; PLAbending; PLA impact modification; PLA copolymerization; PLA nucleation and stereocomplexation; and Biocomposite PLA.

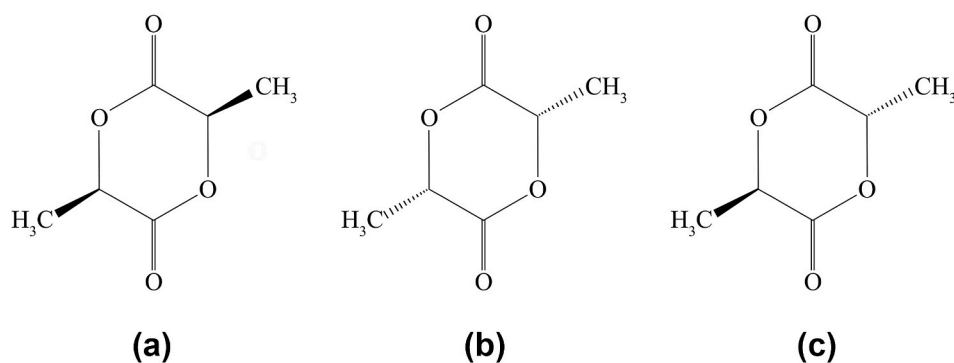

Fig. 4. Lactide types: L-lactide (a), D-lactide (b), D,L-lactide or meso-lactide (c).

beet). Being an antioxidant, lactic acid is an important food industry compound (E270) as a preservation agent, therefore it is produced in high amounts.

PLA can be produced from lactic acid or lactide, in mainly three ways: direct polycondensation (from lactic acid), azeotropic condensation (from lactic acid), and ring-opening polymerization (from lactide) (Fig. 5). The resulting PLA has the roughly same properties independently of the process used.

PLA can be considered the copolymer of L-lactic and D-lactic acid, in most cases of L-lactic acid as the main component since the bacteria used for fermentation usually produce this type of lactic acid. When PLA is made entirely from L-lactic or D-lactic acid, it is referred to as PLLA and PDLA, respectively. PLA refers to a general Poly(lactic acid) grade containing typically about 1–15% of D-lactic acid (or D-lactide). Most properties of PLA (mechanical, thermal, crystallization, degradation properties), change with L-lactic acid (or lactide) content.

3. Properties of PLA

3.1. Main mechanical and thermal properties

We compared the basic properties, such as mechanical, thermal,

HDT, Vicat softening, and shrinkage properties of amorphous and annealed PLA, to those of PP, ABS, and Polycarbonate (PC) (Table 1). Note that the properties may vary according to the various grades (primarily due to molecular weight (M_w)). Still, we can use these data to compare these thermoplastics.

3.2. Crystal structure

Related to its crystal structure, PLA can be crystallized into α , β , γ and η (also called stereocomplex) crystalline forms [16–24]. The most common and stable crystal form is α with an orthorhombic unit cell. This form develops when PLA is cooled from a melt or solidified from a solution [17,18]. The β form with a trigonal unit cell can be obtained by the recrystallization of the α form with the use of a high drawing force and a high temperature [19,20], while the γ form with an orthorhombic unit cell develops by epitaxial crystallization on a hexamethyl benzene substrate [21]. Most papers examine the α crystal form, since this polymorph develops during the melt processing of PLA. Accordingly, this form has the most practical significance from a processing point of view. Besides the α form, there is a less ordered, less stable form called α' with greater lattice spacing.

Many authors have examined the structure of the α' and α form, how

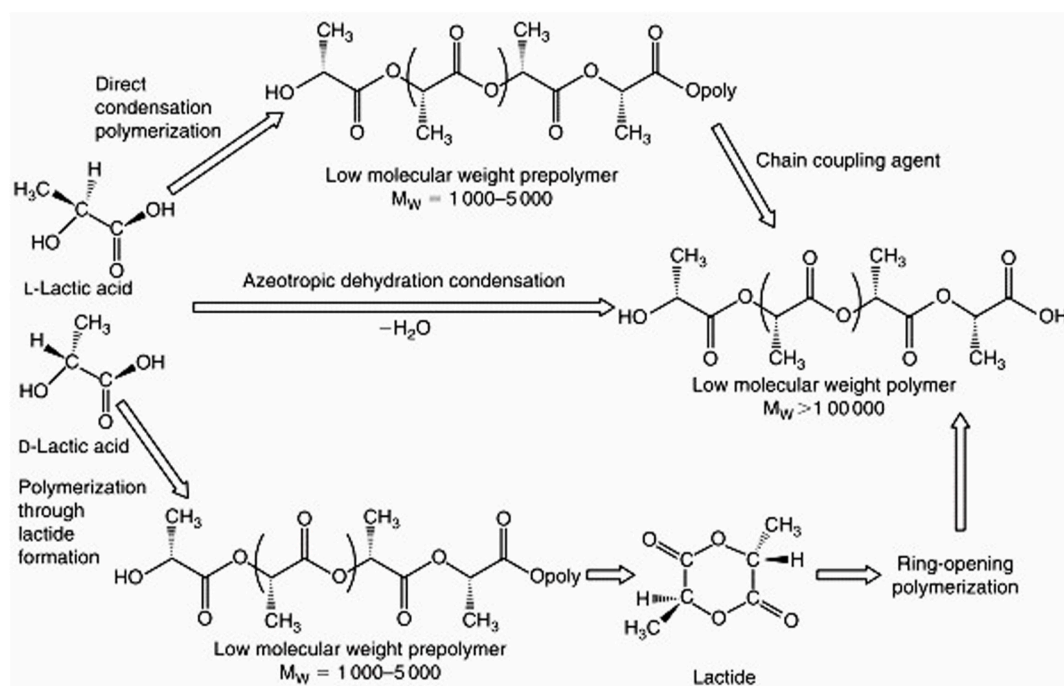

Fig. 5. Producing techniques for PLA (reprinted from “L.T. Lim, R. Auras, M. Rubino, Processing technologies for poly(lactic acid), Prog. Polym. Sci., 33 (2008), 820–852”, Copyright (2008), with the permission from Elsevier).

Table 1
Main properties of PLA compared to PP, ABS, and PC [33].

Property/Material	PP	ABS	PC	Amorphous PLA	Annealed PLA
Density, g/cm ³	0.9	1.06	1.20	1.24	1.29
Tensile strength, MPa	30	50	65	59	66
Tensile modulus, MPa	1600	2400	2400	3750	4150
Elongation at break (ϵ), %	>150%	40	6	2.2	2.0
Flexural strength, MPa	40	75	85	106	119
Flexural modulus, MPa	1400	2500	2400	3650	4150
Charpy impact strength (unnotched), kJ/m ²	45	60	not broken	20	35
Charpy impact strength (notched), kJ/m ²	10	22	70	3	7
Glass transition temperature, °C	0	110	150	55	55
Melting temperature, °C	165	220	250	155	155
Heat Deflection Temperature (HDT at 0.45 MPa load), °C	65	95	130	55	120
Vicat softening, °C	62	85	118	53	115
Shrinkage, %	0.8	0.5	0.6	0.4	0.4

they develop, and how the crystallization temperature (T_c), crystallization time (t_c) and molecular weight (M_w) influence the melting behavior of PLA [25–30]. They used Differential Scanning Calorimetry (DSC), Wide-Angle X-ray Diffraction (WAXD) and Fourier Transformation Infrared Spectroscopy (FTIR). According to our current knowledge, the development of the α and α' forms is highly dependent on T_c (Fig. 6).

Only the less ordered α' and only the more ordered α crystal form develops when PLA is crystallized below 100 °C or above 120 °C, respectively. When PLA is crystallized between these two temperatures, a mixture of the α' and α forms will be generated, and as T_c is increased, the higher the α to α' ratio will be. When examining the melting of these crystal forms, we found that depending on T_c , and thus the α' and α crystal form content, a multiple melting behavior exists. A small exothermic peak appeared just before melting when T_c was below 100 °C. This could be related to the α' to α phase transition, directly followed by the melting of the newly formed α phase. This small exothermic peak just before melting—representing the α' to α transition—was found not to be a melt-recrystallization process but a solid phase transition without the melting of the α' phase [26]. On the other hand, this small exothermic peak disappears, and an additional melting endothermic peak appeared when T_c was between 100 °C and 120 °C. Accordingly, the melting process becomes bimodal. Both endothermic

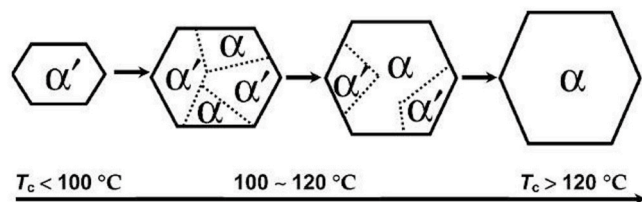

Fig. 6. Proposed model for the crystal modifications acquired under various crystallization temperatures (reprinted from “J. Zhang, K. Tashiro, H. Tsuji, A.J. Domb, Disorder-to-order phase transition and multiple melting behavior of poly (L-lactide) investigated by simultaneous measurements of WAXD and DSC, *Macromolecules*, 41 (2008), 1352–1357”, Copyright (2008), with the permission from American Chemical Society).

peaks were considered to relate with the melting of the α phase, while the height of this newly appeared endothermic peak increases with increasing T_c . The lower temperature endothermic peak is related to the synchronous melting of the original α form crystals and the α' to α crystalline phase transition (in this case, in a melt-recrystallization process and not in a solid state), while the higher temperature endothermic peak is related to the melting of the crystals formed during the α' to α crystalline phase transition. Only one melting endothermic peak appeared when T_c was above 120 °C, which was due to the melting of the α phase.

Finally, by melt mixing optically pure PLLA and PDLA, the η or stereocomplex crystal structure develops with a triclinic unit cell. The stereocomplex PLA crystal structure has unique properties including increased melt temperature, increased heat deflection temperature (as a product) or hydrolysis resistance, just to name a few. Its properties, and the methods for developing a stereocomplex crystal structure are discussed in Chapter 5.2.

3.3. Thermomechanical properties

The thermomechanical properties, and mainly the storage modulus of PLA as a function of temperature, are very important because they directly relate to its practical usability. In most cases, thermomechanical properties are measured by Dynamic Mechanical Analysis [397]. The storage modulus of injection molded and thus practically amorphous PLA can be seen in Fig. 7.

As can be seen, PLA has a storage modulus of around 3 GPa, which sharply drops right above the glass transition temperature (T_g , ~60 °C) to an unacceptable level of a few MPas. In this region, the material is rubber-like. Interestingly, when the temperature is further increased, the modulus of PLA increases, which can be explained by cold crystallization. During cold crystallization, the crystallinity of the specimen increases, resulting in a higher modulus. Finally, as crystallization finishes and the temperature is further increased, the PLA ends up in a molten (plastic) state—its modulus drops around 140–150 °C (for PLLA, it is around 170 °C). If cold crystallization is exploited as an annealing process to increase crystallinity, the storage modulus curve of the specimens will be different based on the crystalline ratio developed during annealing (Fig. 8).

If PLA specimens are annealed, thus their crystallinity is increased, a huge drop in modulus above T_g can be avoided (there will always be a certain drop), and therefore, almost a constant modulus can be maintained in the region of 80 °C–120 °C. Accordingly, and most importantly, the main advantage of crystalline PLA compared to amorphous PLA is an increase in HDT, since amorphous PLA only has an HDT around

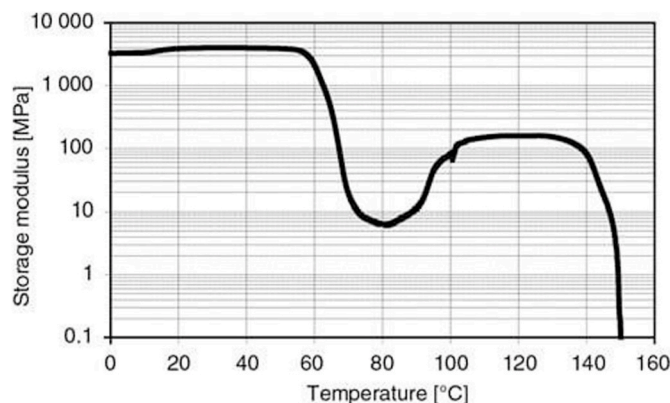

Fig. 7. The storage modulus of injection-molded PLA specimen (reprinted from “T. Tábi, I.E. Sajó, F. Szabó, A.S. Luyt, J.G. Kovács, Crystalline structure of annealed poly(lactic acid) and its relation to processing, *Express Polym. Lett.*, 4 (2010), 659–668”, Copyright (2010), with the permission from Express Polymer Letters).

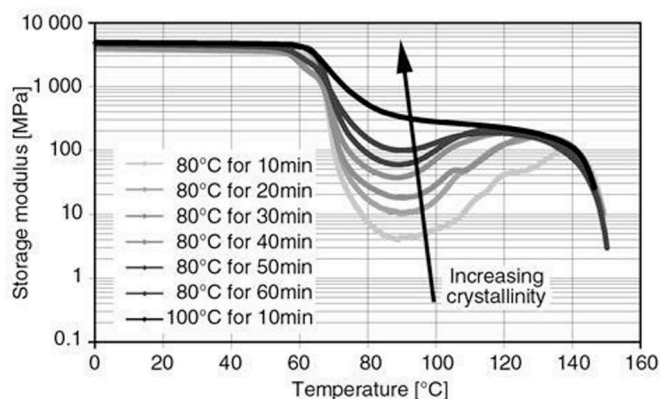

Fig. 8. The storage modulus of injection-molded PLA specimen as a function of annealing time (crystallinity) (reprinted from “T. Tábi, I.E. Sajó, F. Szabó, A.S. Luyt, J.G. Kovács, Crystalline structure of annealed polylactic acid and its relation to processing, *Express Polym. Lett.*, 4 (2010), 659–668”, Copyright (2010), with the permission from Express Polymer Letters).

50–55 °C. In comparison, fully crystallized (annealed) PLA has a much higher HDT, even above 100 °C. Unfortunately, injection-molded PLA products cannot simply be annealed above T_g for a high HDT, due to three reasons:

- The stiffness of the PLA part will drop, so it will lose dimensional accuracy.
- All the molding internal stresses will be relieved, resulting in loss of dimensional accuracy.
- During cold crystallization, as crystallinity increases, the density of PLA increases, which leads to slightly shrunken parts and again a loss of dimensional accuracy.

In the literature, the relationship between crystallinity and HDT is only reported a few times. Tábi et al. [31] measured the connection between crystallinity and HDT using crystallized (annealed) samples (Fig. 9).

They found that up to 35% crystallinity, the HDT of 3001D grade PLA, only slightly improves, from 55 °C to 58 °C. A further increase in crystallinity, up to its maximum of 44% (for 3001D and annealing at 80 °C), the HDT linearly increased from 58 °C to 97 °C. Additionally, they also investigated the effect of crystallization temperature (T_c), and

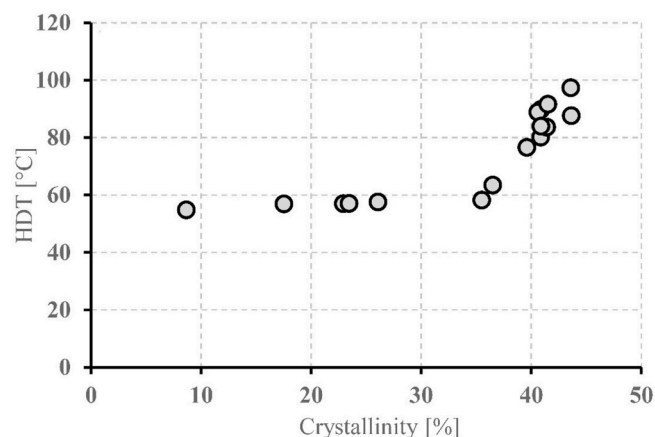

Fig. 9. HDT and a function of crystallinity for 3001D grade PLA annealed at 80 °C for various times (reprinted from “T. Tábi, S. Hajba, J.G. Kovács, Effect of crystalline forms (α' and α) of poly(lactic acid) on its mechanical, thermo-mechanical, heat deflection temperature and creep properties, *Eur. Polym. J.*, 82 (2016), 232–243”, Copyright (2016), with the permission from Elsevier).

found that despite practically the same crystallinity reached, the HDT further improved from 97 °C up to 151 °C, due to the gradual change in the crystal structure from the less ordered α' to the more ordered α crystal form (Fig. 10).

4. Methods to enhance the ductility of PLA

Since PLA is an inherently brittle polymer, its ductility needs to be improved for wider applicability. There are two groups of methods to achieve this. The first includes physico-chemical ways of improving the ductility of PLA through plasticizers, impact modifiers, blending, or copolymerization. However, PLA can be made more ductile by mechanical modification techniques, such as stretching (uni- or bi-axial), for instance. All these possibilities are discussed in this Section.

4.1. Plasticizing

The use of plasticizers has two effects. Firstly, PLA is a high-strength, high-stiffness, but low impact strength material. Thus, it behaves as a rigid polymer when it is exposed to dynamic effects. In this case, plasticizers are used to make the polymer behave in a more plastic way and make it tougher, increasing its impact strength and elongation at break. However, this can only be achieved at the cost of some strength and stiffness reduction. Moreover, elongation at break usually only increases at higher plasticizer content (>10 wt%). Secondly, plasticizers can also be used to enhance the molecular chain mobility of the given polymer by diffusing into the polymer chains and decreasing the glass transition temperature (T_g). Thus, in this case, the purpose of a plasticizer is to improve the overall crystallization of the base polymer. Moreover, crystallization is also enhanced by the widened crystallization window between T_g (decreased by the plasticizer) and the melting temperature (T_m). Note that T_m is also decreased by the plasticizer, but usually, the temperature difference between T_g and T_m increases [32,33]. For PLA, both reasons for using a plasticizer are essential.

In general, all plasticizers are carbon-based compounds with a linear or cyclic carbon chain. The smaller molecular size of a plasticizer compared to the that of the base polymer allows it to occupy intermolecular spaces between the base polymer chains, reducing secondary forces among them and thus leading to increased molecular chain mobility. The lower the M_w , the higher the plasticizing effect is, and generally, the better miscibility/solubility is. However, low M_w compounds tend to migrate out of the polymer over time. Higher M_w compounds, like oligomers, are less likely to migrate out of the polymer, but

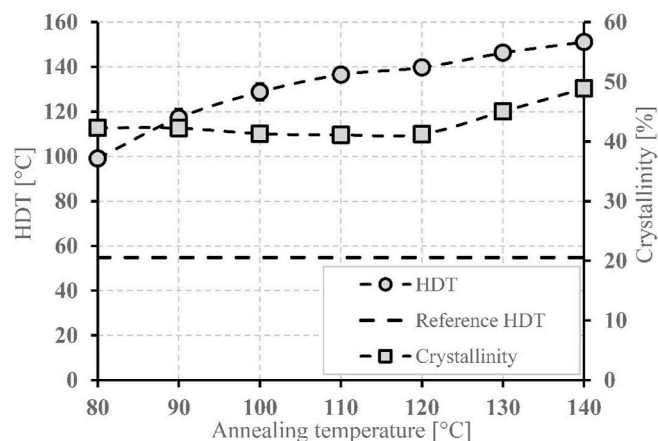

Fig. 10. HDT and a function of annealing temperature for 3001D grade PLA annealed at 1 h (reprinted from “T. Tábi, S. Hajba, J.G. Kovács, Effect of crystalline forms (α' and α) of poly(lactic acid) on its mechanical, thermo-mechanical, heat deflection temperature and creep properties, *Eur. Polym. J.*, 82 (2016), 232–243”, Copyright (2016), with the permission from Elsevier).

they have a far reduced plasticizing effect and are less miscible/soluble in the polymer (higher possibility of phase separation) as well.

Typically, the amount of plasticizer necessary for both a substantial reduction of T_g of PLA and good mechanical properties is 10–20 wt% but adding more than 20–30 wt% plasticizer to the polymer usually leads to phase separation (depending on the M_w of the plasticizer). Plasticization is thus limited by the amount of plasticizer to be compounded with PLA. Moreover, plasticizing efficiency depends on miscibility with the host polymer, M_w and the amount of plasticizer used.

A suitable plasticizer for PLA should reduce the T_g and increase elongation at break while being renewable resource-based, biodegradable, non-volatile, non-toxic (for food packaging), and biocompatible (for medical applications) and it should have minimal leaching or migration during storage. When plasticized PLA is used to make injection molded parts, an inadequately selected plasticizer may migrate out of the base polymer, causing product safety problems, which is unacceptable in food contact applications. Accordingly, one of the goals of the literature review was to find out what kind of plasticizers have been used for PLA, how effective they have been, and, most importantly, which ones can be used in applications where migration is not allowed. We found a large number of papers on PLA plasticization [32–50], [51–71], [72–92], [93–113], [114–133]. The most investigated plasticizers are listed in Table 2.

A thorough examination of the literature revealed that a great number of plasticizers were tested. However, a truly suitable plasticizer for PLA must satisfy many criteria such as compatibility, miscibility (solvation), low volatility, resistance to migration (stability over time), being non-toxic, and others. Compatibility between plasticizer and polymer is vital for effective plasticization, and various parameters can indicate this feature, including polarity, hydrogen bonding, dielectric constant, and solubility parameters. Another essential factor is solvation, as plasticizers with solubility parameters close to those of the base polymer require less energy to fuse or solvate the polymer. If a plasticizer is soluble in the polymer, the plasticized polymer will show a single T_g in a DSC test. Moreover, permanence is related to volatility and resistance to migration and extraction in water, solvents, and oils. Finally, a suitable plasticizer should not crystallize over time, should not be hydrophilic (migration upon contact with water), and should not be polar (water-soluble).

Low M_w plasticizers (<500–1000 g/mol) have the problem of migrating, owing to their high mobility within the PLA. Therefore, plasticizers with relatively high M_w and low mobility are desirable because of their higher stability. Consequently, oligomers appear to be ideally suited to be blended with PLA to provide enough plasticization and to avoid migration. However, even if the plasticizer meets all requirements, the crystal structure of PLA can still cause problems.

PLA is a semi-crystalline polymer, and plasticizers are incorporated primarily into the amorphous regions. Thus an increase in crystallinity over time can change the compatibility of the plasticizer with PLA and induce phase separation and/or migration of the plasticizer. Generally, any factor influencing the crystallinity or crystalline behavior of PLA can disturb distribution and the compatibility of plasticizers with PLA. This includes the crystallization of the plasticizer over time, for example, in the case of PEG. Unfortunately, PLA can crystallize over time as it is susceptible to physical aging, where the amorphous structure rearranges and crystallinity increases. Aging is a well-known phenomenon typical of glassy materials like PLA and is responsible for a change in properties over time. It happens when the glassy polymer is stored at a temperature near T_g . For PLA, the temperature difference between storage temperature (~20–25 °C) and T_g (50–55 °C) is only 25–35 °C, while plasticizers can decrease T_g even more, decreasing this temperature difference and speeding up physical aging. Physical aging of the amorphous phase can induce phase separation or the migration of the plasticizer, which increases brittleness to the brittleness of neat PLA. Moreover, a plasticizer will most likely migrate at elevated temperatures (>100 °C), which is called thermally induced migration. The main question is whether the

Table 2
The most investigated plasticizers for PLA.

Plasticizer	Reference
Single plasticizers	
Acetyl Glycerol Monolaurate (AGM)	[57]
Acetyl Tributyl Citrate (ATB)	[43,44,58,61–72,118]
Acetyl Triethyl Citrate (ATC)	[38,61,62,72]
Adipate ester	[120]
Cardanol oil	[124]
Citrate Ester (CE)	[39]
Coconut oil	[122]
Di(Isonyl) Cyclohexane-1,2-Dicarboxylate (DICD)	[73]
Di- or Bis(2-ethylhexyl)-adipate (known as Dioctyl Adipate (DOA))	[84,85,87]
Diethyl Bishydroxymethyl Malonate (DBM)	[77,94]
Dibutyl Sebacate (DBSE)	[57]
Diethyl Adipate (DEA)	[62]
Diethyl Hexyl Phthalate (DEHP)	[54]
Diethyl Bishydroxymethyl Malonate reacted with adipoyl dichloride	[94]
Diethyl Bishydroxymethyl Malonate reacted with succinyl dichloride	
Diisodecyl Adipate (DIA)	[62]
Dioctyl Terephthalate (DOTP)	[98]
Epoxidized cardoon seed oil	[127]
Epoxidized jathropa oil	[125]
Epoxidized Karanja Oil (EKO)	[131]
Epoxidized Linseed Oil (ELO)	[95,96,258]
Epoxidized Palm Oil (EPO)	[99]
Epoxidized rubber seed oil	[126]
Epoxidized Soybean Oil (ESO)	[258,259]
Epoxidized Palm and Soybean Oil mixture (EPSO)	[99]
Glucose Monoester (GM)	[260]
Glycerol	[39]
Glycerol Triacetate (also known as Triacetine) (GTA)	[37,72,74,83,84]
Isosorbide Dioctoate (ISDO)	[98]
Lapol (trade name, industrial polyester plasticizer)	[101]
Limonene	[88–90]
Maleinized cottonseed oil	[128]
Maleinized hemp seed oil	[130]
Maleinized linseed oil	[128,129]
Monoglyceride	[37]
N-Octyl Lactate (NOL)	[102]
Oligomeric Lactic Acid (OLA)	[132,133]
Oligomeric Malonate Esteramide (OME)	[103]
Partial fatty acid ester	[53]
Poly(1,3-Butylene Adipate) (PBA)	[67,97]
Poly(Ethylene Adipate) (PEA)	[97]
Poly(Ethylene Glycol) (PEG)	[37–40,42–60,113,117,259,261–263]
Poly(Ethylene Glycol) (PEG) monolaurate	[39]
Poly(Propylene Glycol) (PPG)	[51,52]
Poly(1,3-Butanediol) (PBOH)	[57]
Poly(Diethylene Adipate) (PDEA)	[97]
Poly(Hexamethylene Adipate) (PHMA)	[97]
Polymeric adipate	[84–87]
Rice bran oil	[123]
Ricinelic acid	[60]
Soybean oil	[123,258]
Sunflower oil-based oligoester	[264]
Thymol	[91–93]
TriButyl Citrate (TBC)	[37,61,62,72–77]
Tributyrin	[265]
Triethyl Citrate (TEC)	[119]
Triphenyl Phosphate (TPP)	[105]
Various oils including linseed oil	[258]
β -carotene	[106]
Reactive blended plasticizers	
Reactive blended ATB	[107]
Reactive blended PEG	[47]
Reactive blended Poly(Ethylene Glycol MonoAcrylate) (PEGA)	[109]
Reactive blended TBC	[108]
Copolymer or mixed plasticizers	
Mixture of GTA and Oligomeric Poly(1,3-Butylene Glycol Adipate) (OBGA)	[109]
PDLLA-Poly(Ethylene Glycol) (PEG) copolymer	[76]

(continued on next page)

Table 2 (continued)

Plasticizer	Reference
Poly(Ethylene Glycol-co-Citric Acid) copolymer (PEGCA)	[110]
Poly(Ethylene Glycol-co-Propylene-Glycol) copolymer (PEPG)	[55]
Lactic acid and Ethylene Oxide copolymer (PMDO)	[111]

plasticizer migrates at room temperature during storage (aging) or at an elevated temperature (during crystallization). Luckily, increasing the crystalline ratio or decreasing the D-lactide content of PLA will reduce aging (including enzymatic and hydrolytic degradation) of the final product [134,135]. Accordingly, to avoid the change of crystallinity of PLA caused by the plasticizer migration, the highest possible crystalline ratio needs to be developed during the processing of PLA.

To date, various monomers and oligomers have been investigated as potential plasticizers for PLA. However, only a few studies report on the change of properties with time. Even fewer systematically address the related phenomena of phase separation and aging, and their correlation with the resulting macroscopic properties. Based on only their effectiveness in decreasing T_g , we chose the most effective plasticizers. We compared them based on T_g reduction at a plasticizer content of 10 wt%. When plasticizer content was not exactly 10 wt%, we calculated T_g reduction by interpolation or extrapolation. The most effective plasticizers are listed in Table 3.

The results presented in Table 3 are difficult to compare since various PLA grades (M_w , D-lactide content) were used. Nevertheless, we found several plasticizers to be effective. Among them are PEG, PEG monolaurate, reactive blended PEG, OLA, PPG, PEPG, DBSE, ATB, DEA, TBC, GTA, polymeric adipate, limonene, and ELO (in these cases, the plasticizers decreased the T_g of PLA by more than 20 °C when added in 10 wt %). At the same time, most of the selected plasticizers fails the storage test according to their stability over time (migration), or there was no information about it because it was not investigated in the given paper. Evidence of migration or phase separation was found in multiple papers for ATB, DBM, DOA, GTA, NOL, PEG, PEPG, polymeric adipate, PPG, reactive blended ATB, TBC, TEC, and thymol, which were thus rejected from further investigations. What is left as potentially suitable plasticizers are DBSE, DEA, ELO, limonene, OLA, PDEA copolymer, PEG monolaurate, reactive blended PEG, and reactive blended TBC. Unfortunately, these plasticizers only passed because there was no data on their migration except for OLA and reactive blended TBC, which were not only effective, but also exhibited no migration in the investigated 90 days (at 23 °C) and 6 weeks (also at 23 °C) of storage time. Although these plasticizers are the most suitable (as discussed previously), there is still a risk of migration at elevated temperatures or during the physical aging of PLA (the latter effect should be minimized if adequate crystallinity has already developed during injection molding).

As a short conclusion, oligomeric lactic acid (OLA) seems to be a good or maybe the best choice as a PLA plasticizer due to its similar chemical structure, relatively high molar mass, and renewable source (OLA is also produced during PLA production). On the other hand, reactive blended TBC also seems to be a good choice. It uses a different approach, namely to chemically bond the very effective but migrating TBC plasticizer onto the backbone of PLA to avoid migration and phase separation.

4.2. Impact modification

In this subsection, the effect of impact modifiers on the impact properties of PLA is discussed. We define impact modifiers as elastomeric-like materials to distinguish them from blends, where the latter is the mixture of two or more thermoplastics. In this subsection, we review the effect of Natural Rubber (NR), Ethylene-Vinyl Acetate (EVA), and commercially available impact modifiers like Elvaloy and

Table 3

The selected most effective plasticizers of PLA.

Plasticizer (M_w , g/mol)	ΔT_g °C (at 10 wt% plasticizer content)	Migration (or phase separation)	Elongation at break, %	Ref.
ATB (402)	-17	Unknown	240 (at 15 wt%)	[43]
	-34	Unknown	2	[61]
	-15	Unknown	-	[65]
ATB (-)	-18	Thermally-induced migration (125 °C)	-	[64]
	-16	Unknown	50	[67]
	-17	Unknown	-	[68]
	-16	Unknown	85	[71]
	-16	Unknown	-	[72]
DBM (220)	-15	Phase separation and migration during storage (6 weeks, 23 °C)	-	[77]
	-15	Unknown	-	[94]
	-20	Unknown	2.3	[57]
	-24	Unknown	-	[62]
DOA (371)	-17	Phase separation above 5 wt%	-	[84]
ELO (-)	-17	No phase separation (no ageing test was performed)	259	[87]
	-25	Unknown	-	[95]
	-23	Unknown	-	[225]
GTA (218)	-23	Phase separation above 25 wt%, migration during storage	-	[72]
GTA (-)	-17	Phase separation above 25 wt%, migration during storage	-	[72]
Limonene (136)	-20	Migration during storage	355 (at 15 wt%)	[74]
	-20	Unknown	258 (at 20 wt%)	[90]
NOL (-)	-18	Phase separation above 10 wt%	267	[102]
OLA (671)	-15	Unknown	243 (at 15 wt%)	[78]
OLA (706)	-15	Unknown	235 (at 15 wt%)	[78]
OLA (1340)	-15	No migration during storage (90 days, 25 °C)	183 (at 15 wt%)	[80]
OLA (-)	-21	Unknown	32	[39]
	-15	Unknown	-	[46]
	-15	Unknown	750 (at 20 wt%)	[97]
PDEA (2000)	-15	Unknown	220 (at 20 wt%)	[76]
PDLLA-PEG (750) copolymer	-17	Unknown	2	[57]
PEG (200)	-23	Phase separation	2	[57]
PEG (300)	-23	Phase separation	10 (at 15 wt %)	[43]
PEG (400)	-28	Phase separation	9	[39]
PEG (600)	-26	Unknown	-	[47]
	-19	Unknown	2.4	[57]
	-26	Unknown	-	[58]
	-21	Unknown	-	[40]
	-22	Unknown	-	[53]
PEG (1000)	-15	Phase separation	97 (at 20 wt %)	[49]
	-19	Phase separation	3	[57]
	-24	Phase separation	3	[59]

(continued on next page)

Table 3 (continued)

Plasticizer (M _w , g/mol)	ΔT _g °C (at 10 wt% plasticizer content)	Migration (or phase separation)	Elongation at break, %	Ref.
		Phase separation above 10 wt%		
PEG (1500)	-28	Unknown	-	[50]
PEG (2000)	-18	Unknown	-	[58]
PEG (3400)	-16	Unknown	-	[58]
PEG (8000)	-25	Phase separation during ageing (30 days, 23 °C)	-	[46]
	-22	No phase separation	200	[45]
	-21	Phase separation during ageing at 30 wt%	180	[46]
PEG (10000)	-19	Phase separation during storage (2 month, 23 °C)	190	[55]
PEG monolaurate (400)	-24	Unknown	18	[39]
Poly(Ethylene Glycol-co-Propylene-Glycol) copolymer (PEPG) (12000)	-20	Phase separation during storage (2 month, 23 °C)	340	[55]
Polymeric adipate (2000)	-22	Unknown	-	[84]
	-21	Unknown	148	[85]
Polymeric adipate (3400)	-21	Unknown	-	[84]
	-18	Phase separation above 20 wt%	50	[85]
Polymeric adipate (1532)	-19	Migration above 10 wt% during storage (150 days, 23 °C)	5	[86]
	-19	No phase separation (no ageing test was performed)	5	[87]
Polymeric adipate (2565)	-16	Migration above 10 wt% during storage (150 days, 23 °C)	7	[86]
	-16	No phase separation (no ageing test was performed)	7	[87]
PPG (425)	-23	Unknown	524	[51]
PPG (1000)	-22	Phase separation above 10 wt%	473	[52]
Reactive blended ATB (402)	-18	Migration during storage (6 months, 23 °C)	-	[107]
Reactive blended PEG (400)	-27	Unknown	-	[47]
Reactive blended TBC (360)	-19	No migration during storage (6 months, 23 °C)	-	[107]
TBC (360)	-19	Unknown	6	[61]
	-15	Unknown	10	[62]
	-21	Unknown	7	[73]
	-17	Unknown	-	[75]
	-18	Phase separation and	-	[77]

Table 3 (continued)

Plasticizer (M _w , g/mol)	ΔT _g °C (at 10 wt% plasticizer content)	Migration (or phase separation)	Elongation at break, %	Ref.
TBC (-)	-17	migration during storage (6 weeks, 23 °C) Phase separation above 25 wt%, migration during storage	-	[72]
	-20	Migration during storage	350 (at 15 wt%)	[74]
	-20	Unknown	320 (at 20 wt%)	[76]
TEC (276)	-17	Unknown	21	[61]
TEC (-)	-15	Phase separation above 25 wt%	-	[72]
Thymol (-)	-17	Thermally induced migration (100 °C)	13	[92]

Biomax Strong.

4.2.1. Natural rubber

One of the most suitable ways to enhance the impact strength or ductility of PLA is to add another renewable resource-based material, which is ductile [136]. One of these bio-materials is *cis*-1,4-Poly(isoprene), which is the main component of Natural Rubber (NR) and Isoprene Rubber (IR) [137]. NR is still the most important material in the rubber industry, used for the production of tires, among other products, while Synthetic Rubber (SR) is used to substitute NR. The sap of the “rubber-tree” (*Hevea brasiliensis*) is called latex, which is obtained by tapping. Latex is a water suspension of *cis*-1,4-Poly(isoprene) (Fig. 11), where the Poly(isoprene) ratio is around 30–38 wt%.

Nowadays, NR is still mainly obtained from the “rubber tree” by tapping and making a solid material from the suspension. In its unprocessed state, NR is an amorphous elastomer with a density of 0.934 g/cm³. It has poor mechanical properties, and is combustible. It is usually cross-linked (cured) or vulcanized, as it is called in the rubber industry, usually with sulphur. The degree of curing influences mechanical properties and divides rubbers into soft and hard rubbers. The excellent properties of NR, including high toughness, low modulus, biocompatibility, a renewable source, and low cost, make it a perfectly suitable candidate for toughening rigid polymers like PLA [138].

Examining the morphology of PLA/NR blends, we found that there are “island-like” phases of NR in the PLA matrix, and the adhesion between the two phases is weak. The cross-section of PLA/NR and PLA/epoxidized NR (ENR) blends was investigated by Santawitee et al. [139] (Fig. 12). The authors found that the epoxidation of NR leads to better

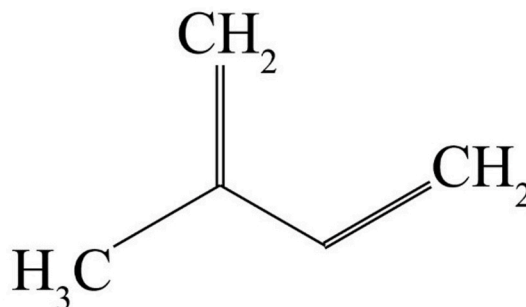
Fig. 11. The repeating unit of *cis* 1,4-Poly(isoprene).

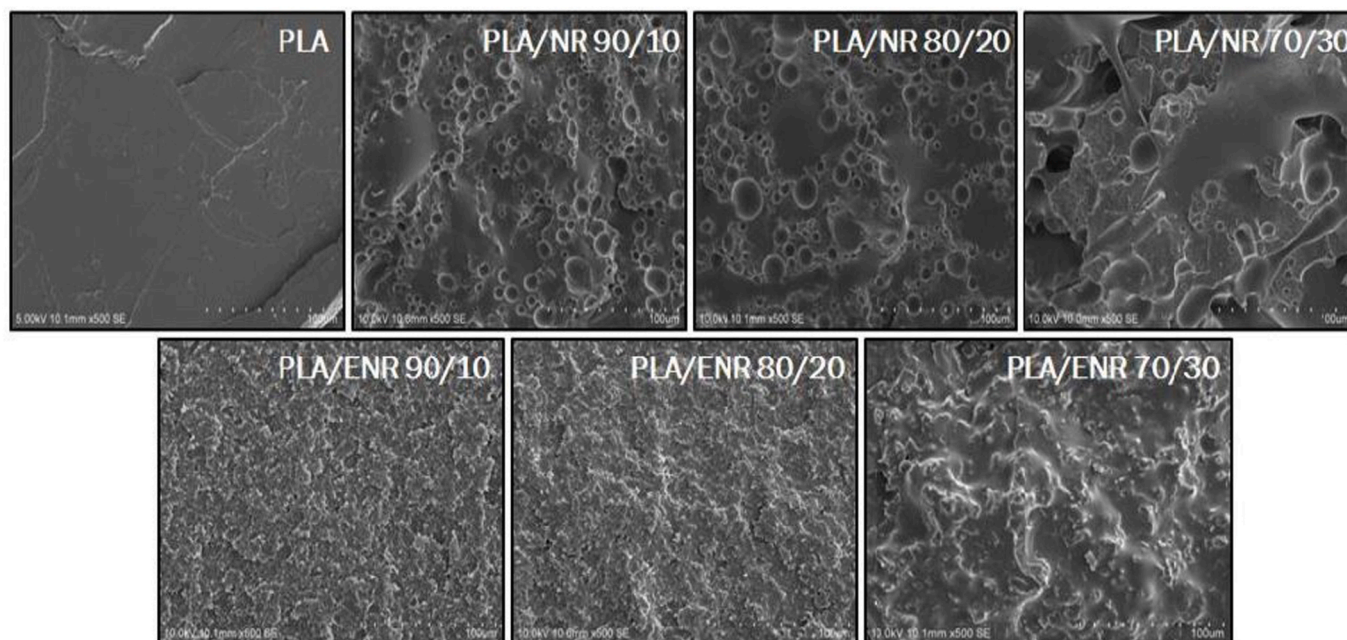

Fig. 12. The fracture surface of PLA/NR and PLA/ENR blends at various NR content (reprinted from “K. Pongtanayut, C. Thongpin, O. Santawitee, The effect of rubber on morphology, thermal properties and mechanical properties of PLA/NR and PLA/ENR blends, Energy Procedia, 34 (2013), 888–897”, Copyright (2013), with the permission from Elsevier).

size distribution (smaller droplets) due to partial compatibility between PLA and ENR. In another study, the morphology of 80/20 wt% and 65/35 wt% PLA/NR blends was investigated. The authors found that the blend which contained 35% NR, had superior mechanical properties, for example, seven times higher impact strength compared to pristine PLA. It is believed that this effect was caused by the web-like structure developed by the NR. This structure was shown by etching the NR content for 1 and 4 min (Fig. 13) [140].

Lopez-Manchada et al. [138] also found that NR forms a droplet-like dispersed phase in PLA, and the processing parameters can influence the diameter of the droplets. For instance, an increase in melt temperature during internal mixing caused the size of the NR droplets to increase, which was the effect of lower PLA viscosity causing the NR droplets to fuse. With this internal mixing technique, an average NR droplet of 1–2 µm was reached. When a cross-linking (or curing) agent is also added to the compound, the 80/20 wt% PLA/NR blend vulcanized

with dicumyl peroxide increased adhesion between the phases. Moreover, the NR phase formed a web-like structure in the PLA, which highly improved the blend's mechanical properties [141]. This web-like, or so-called co-continuous structure is advantageous for high impact resistance and high strain, not only in PLA/NR but also in PLA/other biopolymer blends as well.

It was shown that the addition of NR to PLA improves the crystallization kinetics of the resulting PLA/NR blends. NR has some nucleating effect on PLA, and due to the very slow crystallization of PLA, there was only a minor increase in the final crystallinity of PLA [138–142].

We found that the addition of NR to PLA significantly reduced tensile strength and tensile modulus but highly increased strain at break (Table 4).

As Table 4 shows, above 10 wt% NR content, strain significantly decreased, which was the effect of too large NR droplets, since increasing NR content leads to the fusion of the NR droplets. We found

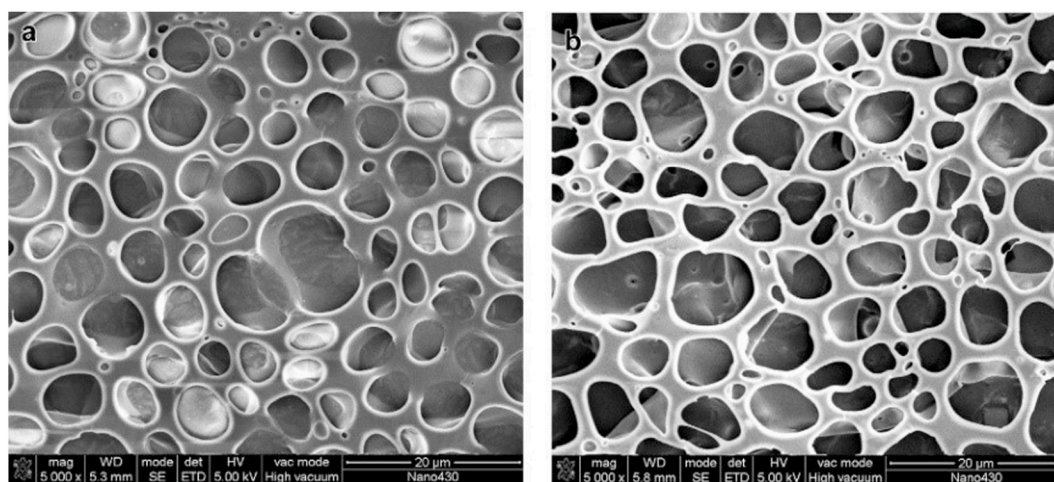

Fig. 13. Scanning electron micrograph of 65/35 wt% PLA/NR blends etched with dichloride-methane for 1 (a) and 4 (b) minutes (reprinted from “C. Xu, D. Yuan, L. Fu, Y. Chen, Physical blend of PLA/NR with co-continuous phase structure: Preparation, rheology property, mechanical properties and morphology, Polym. Test., 37 (2014), 94–101”, Copyright (2014), with the permission from Elsevier).

Table 4
Mechanical properties of PLA/NR blends [141].

Material	Tensile modulus, GPa	Elongation at break, %	Tensile strength, MPa
PLA	3.1 ± 0.04	5.3 ± 0.7	58.0 ± 1.5
PLA + 5 wt% NR	2.5 ± 0.06	48 ± 22	50.4 ± 1.6
PLA + 10 wt% NR	2.0 ± 0.05	200 ± 14	40.1 ± 1.5
PLA + 20 wt% NR	1.8 ± 0.08	73 ± 45	24.9 ± 0.9

that optimal NR content is 10 wt% concerning mechanical properties, crystallization and thermal stability in the investigated 0–30 wt% range [138–140,143,144]. This ductility-increasing effect was also visible on the SEM images (Fig. 14).

Tanrattanukul et al. [143] investigated the mechanical properties of PLA/NR and PLA/ENR blends, and found that ENR had better compatibility with PLA. However, the blend with NR had higher impact strength. They also investigated the effect of the mastication of the NR. During mastication, the M_w and the viscosity of NR decrease, and as a result, particle size decreases. Masticating of the NR significantly increased impact strength when NR droplet size was optimal, around 0.5–1 μm . Below this droplet size, impact strength decreased. Modarress et al. [145] demonstrated that adding 3 wt% ENR increases the elongation at break and impact strength of PLA 45 and 16 times, respectively. The compatibility of PLA/ENR blends compatibility can be improved even more by grafting with maleic anhydride [146]. Another possible compatibilizer for PLA/ENR blends is liquid natural rubber [147]. Chen et al. [141] investigated PLA/NR blends of 80/20 wt% and 60/40 wt% with and without dicumyl peroxide as a vulcanization additive (Fig. 15).

Fig. 15 shows the use of dynamic vulcanization resulted in a PLA/NR (65/35 wt%) blend with a very significant impact strength of $\sim 60 \text{ kJ/m}^2$, while the impact strength of pristine PLA was around 3 kJ/m^2 . Moreover, the same blend did not only have high impact strength but also very high strain ($>200\%$) [142]. Tessian et al. [148] mixed PLA with 10 wt% epoxidized hydrogenated NR that contained 29.84 mol% epoxide and 20.19 mol% hydrogen. The experimental results showed that impact resistance increased to 32.4 kJ/m^2 , and elongation at break increased to 348%, whereas neat PLA has an impact strength of 3.6 kJ/m^2 and an elongation at break of 7.1%. At the same time, tensile strength decreased from 60.0 MPa to 41.8 MPa.

Chen et al. [142] demonstrated that PLA/ENR blends have somewhat better thermal stability than PLA/NR blends, due to the better interfacial adhesion.

The compatibility of NR and PLA can be improved by modifying the

surface of NR particles. For example, Phromma and Magaraphan [149] created a shell on NR particles by admicellar polymerization of the ϵ -caprolactone monomer (NR-ad-PCL). The authors demonstrated that only 5% of NR-ad-PCL increases the impact strength of PLA more effectively than unmodified NR particles (12.5 kJ/m^2 and 9.8 kJ/m^2 , respectively). Moreover, modified NR particles generated better crystals in PLA that readily transformed into perfect crystals of high melting temperature.

Lopez-Manchado et al. [138] investigated the degradation of a PLA/NR blend (90/10 wt%) based on laboratory composting according to the ISO 20200 standard (Fig. 16). Fig. 16 shows that the PLA/NR blend took longer to degrade than pristine PLA, which can be explained by the slower degradation rate of NR, which reduced the overall degradation rate of the PLA/NR blend.

As a short conclusion, NR is a useful bio-based polymer to increase the ductility of PLA. There are NR droplets a dispersed phase in PLA at lower NR content ($<30 \text{ wt}\%$), but with NR content of about 35 wt%, a co-continuous PLA–NR phase structure developed with significantly enhanced impact strength of 60 kJ/m^2 (the impact strength of pristine PLA is 3 kJ/m^2).

4.2.2. Ethylene-vinyl acetate

Ethylene-Vinyl Acetate (EVA) (Fig. 17) is a copolymer of Ethylene and Vinyl Acetate (VA), and a thermoplastic elastomer (not vulcanized) material with high flexibility and toughness.

EVA is a widely used copolymer in the plastic industry. The weight percent of VA in EVA usually varies from 10% to 40%, with the remainder being Ethylene. With increasing VA content, EVA changes from a semi-crystalline thermoplastic polymer (Low-Density Polyethylene (LDPE)) into rubber and again into an amorphous thermoplastic polymer (Poly(Vinyl Acetate) (PVA)). Since PLA shows miscibility with PVA and phase separation when blended with LDPE, the compatibility between PLA and EVA can be tuned with the VA content of EVA, without the need for a further compatibilizer. For high-toughness PLA-based blends, compatibility between the phases is essential. EVA is currently produced from crude oil like “ordinary” plastics and not from biomass, like PLA. However, since both bio-based Ethylene and VA are already on the market, EVA can also be made from renewable resources [150].

Ma et al. [151] examined the VA content in PLA/EVA (80/20 wt%) blends. They found that in a specific range of VA content (between 40 and 70%), both impact strength (from 3 kJ/m^2 to $50\text{--}60 \text{ kJ/m}^2$) and strain at break (from 4% to 300–350%) significantly increased. With lower ($<40\%$) or higher ($>70\%$) VA content EVA, the PLA/EVA blend is brittle (Fig. 18). As Fig. 18 shows, impact strength considerably increases above 15 wt% EVA content (50% VA content EVA), even higher than the impact strength of ABS ($\sim 20 \text{ kJ/m}^2$). The usability of high VA

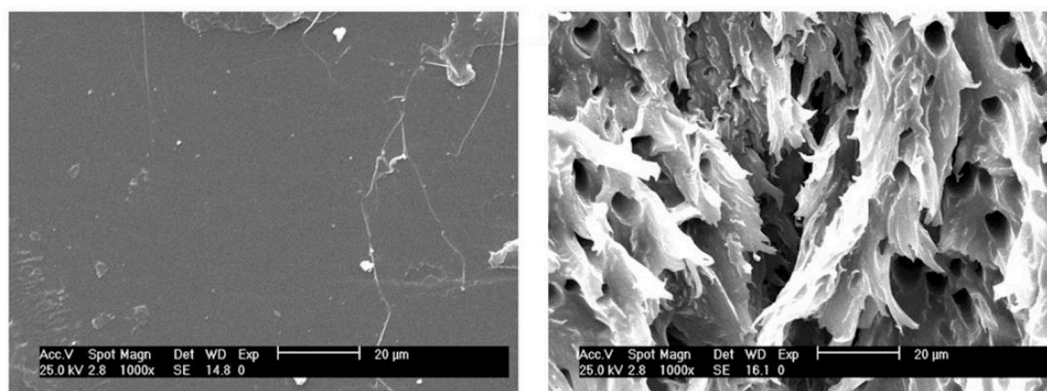

Fig. 14. Scanning electron micrograph of the fracture surface of pristine PLA (a) and PLA/10 wt% NR blend (b) (reprinted from “N. Bitinis, R. Verdejo, P. Cassagnau, M.A. Lopez-Manchado, Structure and properties of polylactide/natural rubber blends, *Mat. Chem. Phys.*, 129 (2011), 823–831”, Copyright (2011), with the permission from Elsevier).

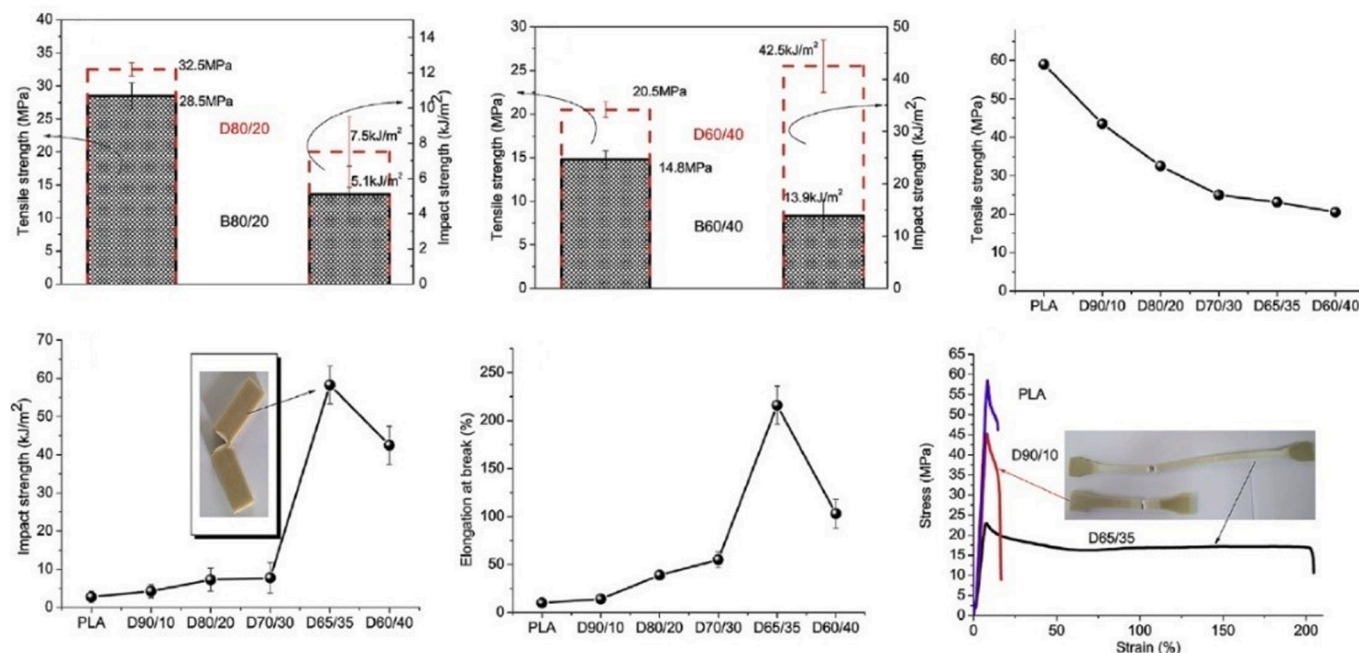

Fig. 15. Mechanical properties of blended PLA/NR (abbreviated as “B”) and dynamically vulcanized PLA/NR (abbreviated as “D”) blends (reprinted from “D. Yuan, C. Xu, Z. Chen, Y. Chen, Crosslinked bicontinuous biobased polylactide/natural rubber materials: Super toughness, “net-like”-structure of NR phase and excellent interfacial adhesion, *Polym. Test.*, 38 (2014), 73–80” Copyright (2014), with the permission from Elsevier).

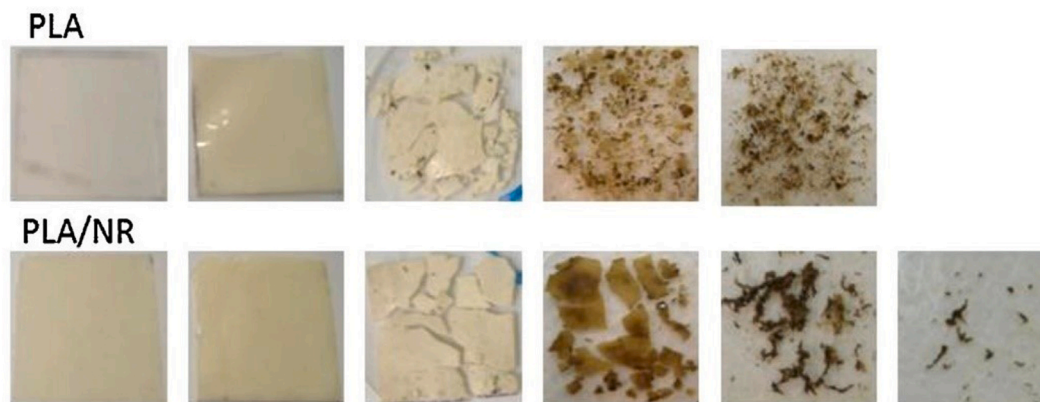

Fig. 16. Composting decomposition of PLA and 90/10 wt% PLA/NR blends. The images of the columns from left to right represent day number 1; 2; 10; 15; 17; 23, and 28 from the start of composting (reprinted from “N. Bitinis, E. Fortunati, R. Verdejo, J. Bras, J.M. Kenny, L. Torre, M.A. López-Manchado, Poly(lactic acid)/natural rubber/cellulose nanocrystal bionanocomposites. Part II: Properties evaluation, *Carbohydr. Polym.*, 96 (2013), 621–627”, Copyright (2013), with the permission from Elsevier).

content EVA in increasing the ductility of PLA was also demonstrated by the same research group not only on compression molded specimens [151] but also on films [152,153]. Yoon et al. [154] pointed out that the strain at break of blends of PLA and high VA content EVA only started to significantly increase above 50 wt% EVA content. This can be explained by the very high VA content of EVA.

Cong et al. [155] investigated the mechanical properties and biodegradation of PLA/EVA (80/20 wt%) blends. In this case, the EVA used had 18% VA content. Ma et al. [151] found that higher VA content EVA is needed for highly ductile PLA/EVA blends, thus with this EVA only moderate results were achieved. 20 wt% EVA content was not enough to increase the strain at break of PLA, and even 40 wt% EVA content only increased the strain of the blend to four times that of neat PLA.

In another set of studies [156–159], scientists used compatibilizers to enhance the compatibility between PLA and EVA. However, Ma et al.

[151] found that PLA shows good miscibility with PVA, thus also when EVA has high VA content. In these studies, various materials were used as compatibilizers, such as Elvaloy (DuPont) [156], 2,5-dimethyl-2,5-di(tert-butylperoxy)hexane (AD) for dynamic vulcanization [157,158] and titanium propoxide or titanium phenoxide for reactive extrusion through transesterification [159]. Elvaloy in 2.5 wt% and 5 wt% [156] did not change the strain of the PLA/EVA (75/25 wt%) blends noticeably. Thus the ductility of PLA only increased when 85–95% EVA was used (Fig. 19). Note that in this study, 18% VA content was used, which is too low to enhance the ductility of PLA at low EVA contents effectively.

Zhang and Lu [157] used the 2,5-dimethyl-2,5-di(tert-butylperoxy)hexane compatibilizer for dynamic vulcanization of the PLA/EVA (70/30 wt%) with 28% VA content in EVA. The authors found that adding 0.3 wt% compatibilizer highly increased the impact strength of the blend. They also found that with 0.3 wt% compatibilizer content, at

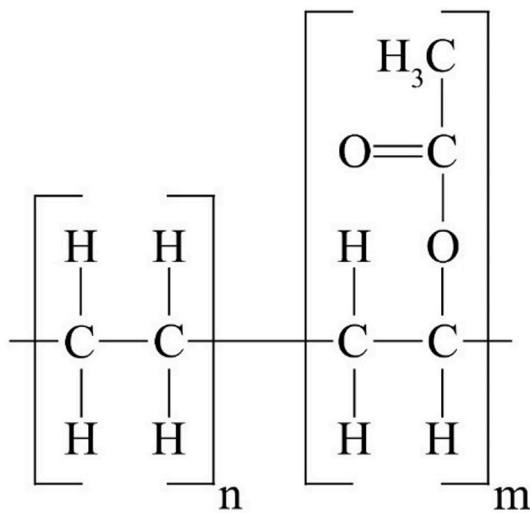

Fig. 17. Structure of ethylene-vinyl acetate (EVA).

least 30 wt% EVA was needed to significantly increase ductility (Fig. 20).

Moura et al. [159] used titanium phenoxide for reactive extrusion through transesterification between PLA and EVA. The researchers used very high EVA content (60 wt%). Even though the applied reactive extrusion made the component compatible, due to the very high EVA content, this blend lacks practical uses.

Finally, Tábi [160] investigated the effect of annealing on the properties of PLA/EVA blends in 0–20 wt% EVA content range with 60% VA content. When PLA was unannealed, even 20 wt% EVA only increased impact strength from 2.3 kJ/m² to 8.7 kJ/m². When pure PLA was annealed at 100 °C, its impact strength increased from 2.3 kJ/m² (unannealed) to 15.2 kJ/m² due to the crystal structure that developed. However, annealed PLA/EVA blends had a very high impact strength of over 65 kJ/m² (Fig. 21). Tábi proved the existence of a toughening mechanism and a positive cross-effect between the crystal structure of PLA and impact modifiers. This finding can be used to achieve very high (even 60 kJ/m²) notched Charpy impact strength with a certain VA content EVA grade and a certain crystal structure of PLA, developed through annealing.

The results indicate that EVA is a very effective impact modifier, and at certain VA contents (between 40% and 70%), it is inherently

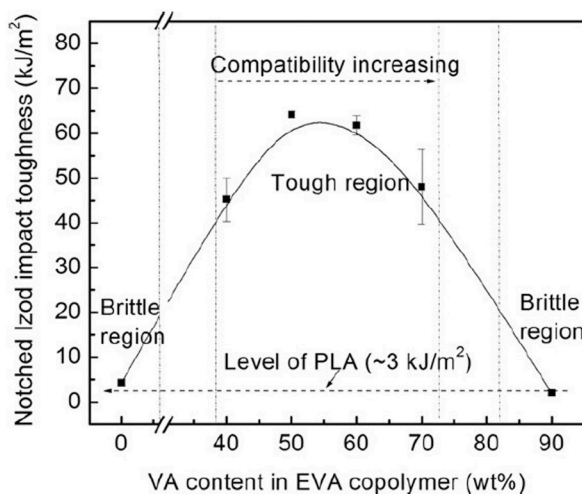

compatible with PLA. However, for maximum impact modification effect, the PLA must be crystallized (annealed), which activates a toughening mechanism of a positive-cross effect between the crystal structure of PLA and EVA. In this case, over 65 kJ/m² notched Charpy impact strength can be achieved with only 15 wt% EVA.

4.2.3. Elvaloy

Elvaloy is the trade name of an impact modifier produced by DuPont. It is a terpolymer of ethylene, butylacrylate, and Glycidylmethacrylate (GMA), or in other literature, it is referred to as Ethylene-Vinyl-Acetate-Glycidylmethacrylate (EVA-GMA). There is a limited number of publications in this field. Pracella et al. [161] added Elvaloy to PLA, and investigated its mechanical properties (Fig. 22). Fig. 22 shows that at least 30 wt% Elvaloy was needed to improve elongation at break significantly, but it came at the cost of a huge loss in strength and modulus.

Aghjeh et al. [162] used Elvaloy more like a compatibilizer between EVA and PLA, but unfortunately, did not measure mechanical properties. They did not only use EVA-GMA to improve the ductility of PLA, but also used Poly(Ethylene-Glycidylmethacrylate) (EGMA) [163], which increased the elongation at break of PLA to over 200%. Furthermore, after EGMA was added, the Charpy notched impact strength of PLA increased several times. The impact strength of PLA with EGMA increased even more after post-production crystallization (annealing) and reached 72 kJ/m², which is significantly higher than even that of ABS (~20 kJ/m²) (Fig. 23).

4.2.4. BioMax Strong

BioMax Strong is the trade name of another impact modifier produced by DuPont. It is an Ethylene-Acrylate Copolymer (EAC). There are only a few publications investigating the use of BioMax Strong for enhancing the ductility of PLA [164–166]. Afrifah and Matuana [166] examined its effect on the ductility of PLA with various D-lactide contents (1.4%, 4%, and 14%). The authors demonstrated that BioMax Strong improved the ductility of low D-lactide content PLA more than the ductility of PLA grades with high D-lactide content. Moreover, 15 wt% of this impact modifier highly increased the impact strength of PLA, and during the tensile tests, the impact-modified PLA showed yielding and improved strain at break (Fig. 24).

4.3. Blending

A polymer blend (thermodynamically stable and compatible) or an

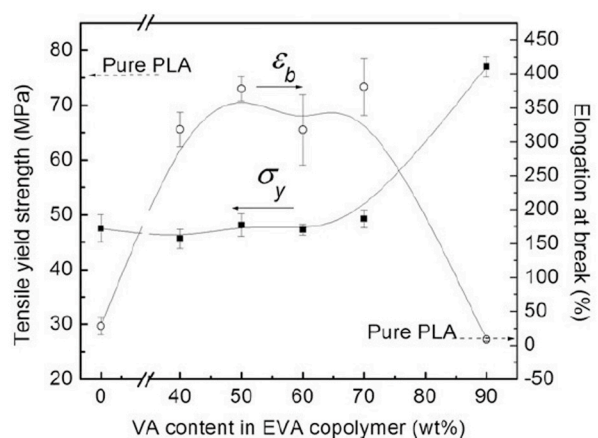

Fig. 18. Mechanical properties of PLA/EVA (80/20 wt%) blends in a function of VA content (reprinted from “P. Ma, D.G. Hristova-Bogaerds, J.G.P. Goossens, A.B. Spoelstra, Y. Zhang, P.J. Lemstra, Toughening of poly(lactic acid) by ethylene-co-vinyl acetate copolymer with different vinyl acetate contents, Eur. Polym. J., 48 (2012), 146–154”, Copyright (2012), with the permission from Elsevier).

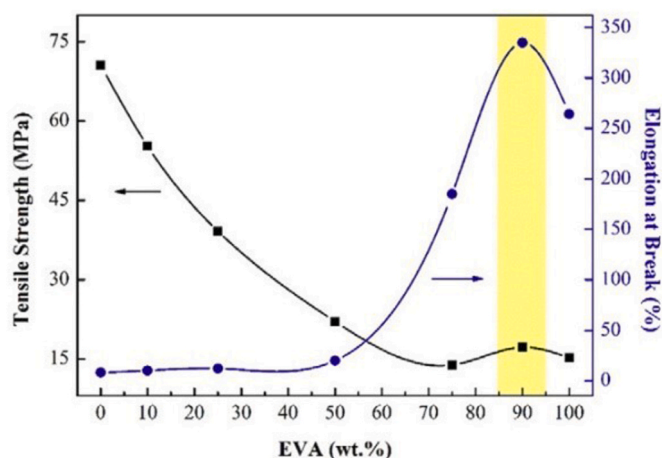
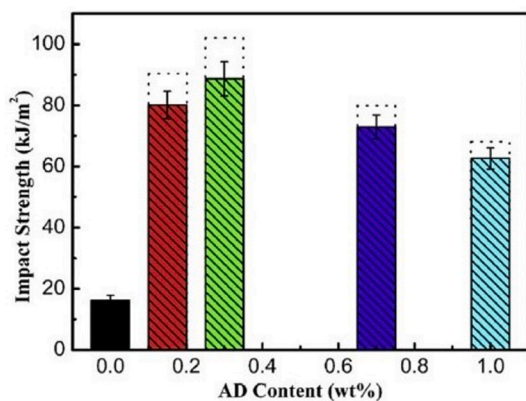

Fig. 19. Tensile strength and elongation at break of PLA/EVA blends with various EVA content (18% VA content EVA was used) (reprinted from “M.R. Aghjeh, M. Nazari, H.A. Khonakdar, S.H. Jafari, U. Wagenknecht, G. Heinrich, In depth analysis of micro-mechanism of mechanical property alternations in PLA/EVA/clay nanocomposites: A combined theoretical and experimental approach, *Mat. Des.*, 88 (2015), 1277–1289”, Copyright (2015), with the permission from Elsevier).

alloy (neither thermodynamically stable, nor compatible) is the physical mixture of two or more thermoplastic polymers, where there is intermolecular interaction between the molecular chains of the mixed polymers. By blending, the main goal is to improve the disadvantageous properties of the components [167,168]. Also, it is a far less complicated and faster process than copolymerization. Our literature review focuses on biopolymer blends, where all of the components are biodegradable polymers, and one of the components is PLA. We found studies on various PLA-based biopolymer blends, where the second component was [3,34]:

- Poly(Butylene Succinate) (PBS) and its copolyesters (Poly(Butylene Succinate-co-Adipate) (PBSA) with the trade name Bionolle [169], Poly(Butylene Succinate-co-L-Lactate) (PBSL) with the trade name GS PLA by Mitsubishi Chem.) [170].
- Aliphatic polyesters and their copolyesters (Poly(ϵ -Caprolactone) (PCL))



(a)

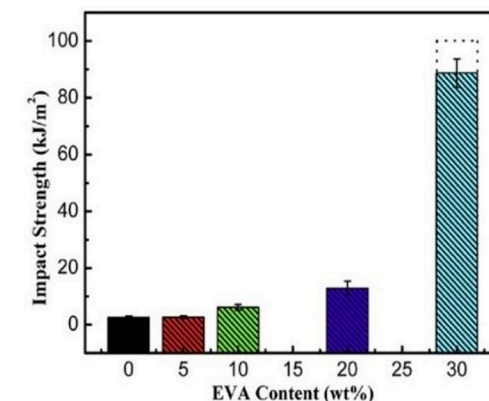

(b)

Fig. 20. The impact strength of PLA/EVA blends with various compatibilizer content (AD) for fixed, 30 wt% EVA content (a) and the impact strength of PLA/EVA blends with various EVA content with fixed 0.3 wt% of compatibilizer content (b) (reprinted from “N. Zhang, X. Lu, Morphology and properties of super-toughened bio-based poly(lactic acid)/Poly(ethylene-co-vinyl acetate) blends by peroxide-induced dynamic vulcanization and interfacial compatibilization, *Polym. Test.*, 56 (2016), 354–363”, Copyright (2016), with the permission from Elsevier).

- Poly(HydroxyAlkanoate) (PHA) [171,172] and its copolyesters (Poly(HydroxyOctanoate) (PHO))
- Poly(Hydroxy Butyrate) (PHB) [173] and its copolymers (Poly(Hydroxy Butyrate-co-Valerate) (PHBV))
- Aliphatic-Aromatic Copolyesters (Poly(Butylene Adipate-co-Terephthalate) (PBAT))

The main properties of the most important biopolymers, namely PBS, PCL, PHA, PHB, PHBV, and PBAT, are collected in Table 5 and compared to PLA.

4.3.1. PLA/PBS blends

PLA/PBS blends are thermodynamically immiscible, and phase separation occurs [174–178]. PBS can be well dispersed into the PLA phase below 8.4 wt%, while in the 8.4–42 wt% range, PLA and PBS develop a co-continuous phase. Above 42 wt%, crystallization induced phase separation occurs, where the PLA will take the role of the dispersed phase [174,175,179,180].

Due to the immiscibility of the components, adhesion between the

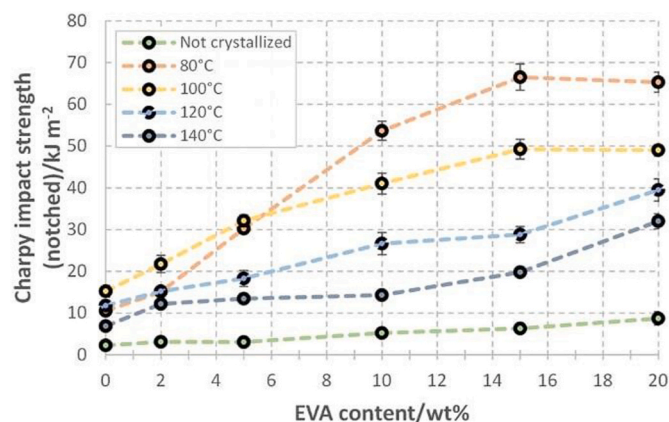

Fig. 21. The Charpy impact strength of PLA/EVA blends as a function of EVA content and annealing conditions (reprinted from “T. Tábi, The application of the synergistic effect between the crystal structure of Poly(Lactic Acid) (PLA) and the presence of Ethylene Vinyl Acetate copolymer (EVA) to produce highly ductile PLA/EVA blends, *Journal of Thermal Analysis and Calorimetry*, 138 (2019), 1287–1297”, distributed under the terms of the Creative Commons CC BY and does not require permission to reuse).

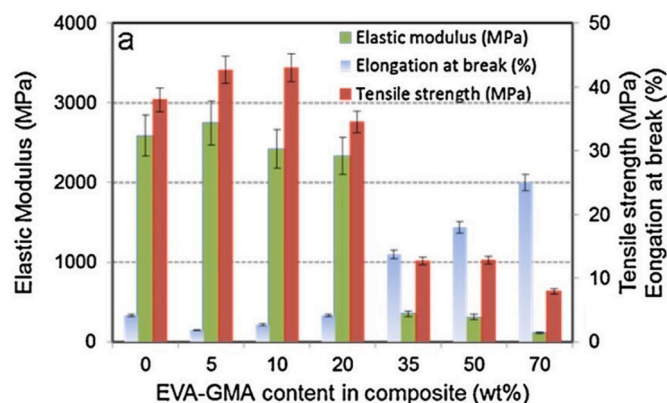

Fig. 22. Mechanical properties of PLA/Elvaloy (EVA-GMA) blends (reprinted from “M. Pracella, M.M.-U. Haque, M. Paci, V. Alvarez, Property tuning of poly(lactic acid)/cellulose bio-composites through blending with modified ethylene-vinyl acetate copolymer, Carbohydr. Polym., 137 (2016), 515–524”, Copyright (2016), with the permission from Elsevier).

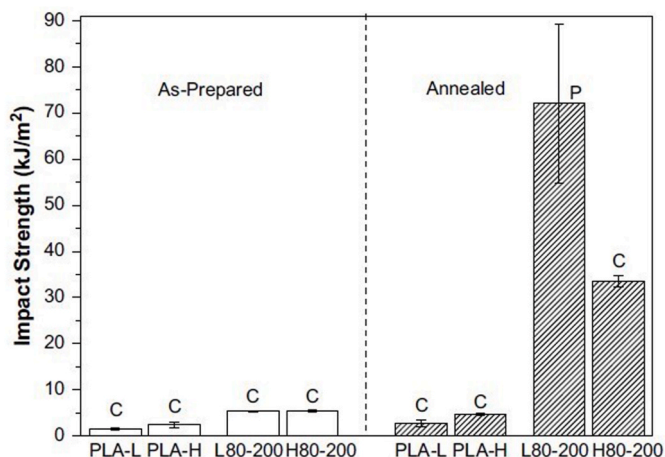

Fig. 23. Impact strength of not crystallized and crystallized PLA with 20 wt% of EGMA content. PLA-L and PLA-H refers to low and high M_w PLA grades (reprinted from “H.T. Oyama, Super-tough poly(lactic acid) materials: Reactive blending with ethylene copolymer, Polym., 50 (2009), 747–751”, Copyright (2009), with the permission from Elsevier).

two phases is low [180]. Qu et al. [181] tested various additives (nanoparticles, molecular chain extenders and compatibilizers) to increase adhesion between the two phases. They found that calcium sulfate can increase the flexural strength and modulus of PLA by 5% and 15%, respectively. At the same time, 2 wt% of the chain extender Triphenyl Phosphite (TPH) and 10 wt% of the copolyester PBSA improved the impact strength of NatureWorks 2002D grade PLA from 6.76 kJ/m² to 16.4 kJ/m² [182].

Researchers found that 0.15 wt% of the reactive processing agent Lysine Triisocyanate (LTI) in a blend of 90/10 wt% PLA/PBS produced an impact strength of 60 kJ/m², while the same amount of LTI in a 80/20 wt% PLA/PBS blend prevented breakage during impact tests altogether [183–186].

4.3.2. PLA/PCL blends

The PLA and PBS are immiscible as well, and there is only weak adhesion between the phases [187,188]. Washburn et al. [187] found that above 50 wt% PLA content, the PLA forms a continuous phase, while PCL is in the form of isolated droplets. At 50 wt% PLA and PCL content, the blend has co-continuous morphology. Elongation at break increases, while tensile strength and modulus significantly decrease

with increasing PCL content (Fig. 25).

Shin and Han [189] tested numerous agents to improve the compatibility between PLA and PCL. One of them is a widely used reactive compatibilizer named Glycol Methacrylate (GMA) [189]. GMA increased the tensile strength of an 80/20 wt% PLA/PCL blend by 150%.

Another compatibilizer tested was LTI, and it improved the flexural strength and modulus of an 85/15 wt% PLA/PCL blend by 15%; at the same time, it increased impact strength significantly even when it was used in small amounts [190,191] (Table 6).

Also, Chavalitpanya and Phattanasuddee [192] improved interfacial adhesion with the PEG/PPG block copolymer. 7.5 wt% of PEG/PPG in an 80/20 wt% PLA/PCL blend increased the crystallinity of the blend from 23.8% to 33.5%.

Bai et al. [193] added 20 wt% PCL and 1 wt% of the nucleating agent TMC-328, and injection molded the compound into a cold and a hot mold to achieve various degrees of crystallinity of PLA. Interestingly, they found that with a cold mold, they achieved the highest impact strength when the average particle size of PCL was around 1 μ m, while with a hot mold, the highest impact strength was measured when the average PCL particle size was around 0.4 μ m.

We found that crystallized PLA/EVA blends had higher impact strength [160]. Also, in another study, Bai et al. [194] added 5, 10, 15 and 20 wt% of PCL and 1 wt% of the nucleating agent TMC-328 to PLA, and injection molded the compound into molds of various temperatures between 50 °C and 130 °C to vary the crystallinity of PLA. They found that PLA/PCL compounds with highly crystalline PLA have greatly improved impact properties.

4.3.3. PLA/PHA blends

Poly(hydroxy alkanooates) (PHA) are ductile, aliphatic, semi-crystalline, thermoplastic bio-polyesters. PHA polymers can be processed with conventional processing equipment and are ductile and more or less elastic, depending on their composition. They differ in their properties due to their chemical composition. Processability, impact strength, and flexibility improve with a higher percentage of valerate in the material. PHB is similar in its material properties to PP. It has good resistance to moisture, and good aroma barrier properties, while PHBV is tougher and less stiff, and it may be used as a packaging material. The T_g of PHBV is around 5 °C, while its T_m is around 150 °C, which makes it a tough polymer at room temperature with a tensile modulus of 900 MPa and an elongation at break of around 15%. These properties make it similar to PP. Amor et al. [195] investigated PLA/PHBV blends with added OLA as plasticizer. Adding 10 wt% PHBV to PLA did not change elongation at break significantly, but an additional 1% of OLA increased elongation to 15%.

4.4.4. PLA/PBAT blends

Poly(butylene adipate terephthalate) (PBAT) is a ductile, aliphatic, semi-crystalline, thermoplastic bio-polyester, which is generally marketed as a fully biodegradable alternative to low-density polyethylene. They have many similar properties, including low elastic modulus and stiffness, but high flexibility and toughness, making PBAT suitable for many similar applications, such as plastic bags. It can be blended with the stiff and high-strength PLA, resulting in biopolymer blends with properties in between those of the two polymers.

Jiang et al. [196] produced PLA/PBAT blends with 5, 10, 15, and 20 wt% PBAT content. They found the components incompatible and a typical two-phase blend developed with the PBAT evenly dispersed in the PLA matrix. With increasing PBAT content, the blend showed decreasing strength and modulus but increasing impact strength. Unfortunately, this increase in impact strength was rather small, and again the cross-effect between crystallized PLA and the presence of the PBAT was not investigated. In another study, Zhang et al. [197] prepared PLA/PBAT blends using GMA as a reactive compatibilizer. They added 1 wt% GMA to PLA/PBAT blend containing 30 wt% PBAT, and the Charpy impact strength of the blend increased from 15 kJ/m² to 32 kJ/m².

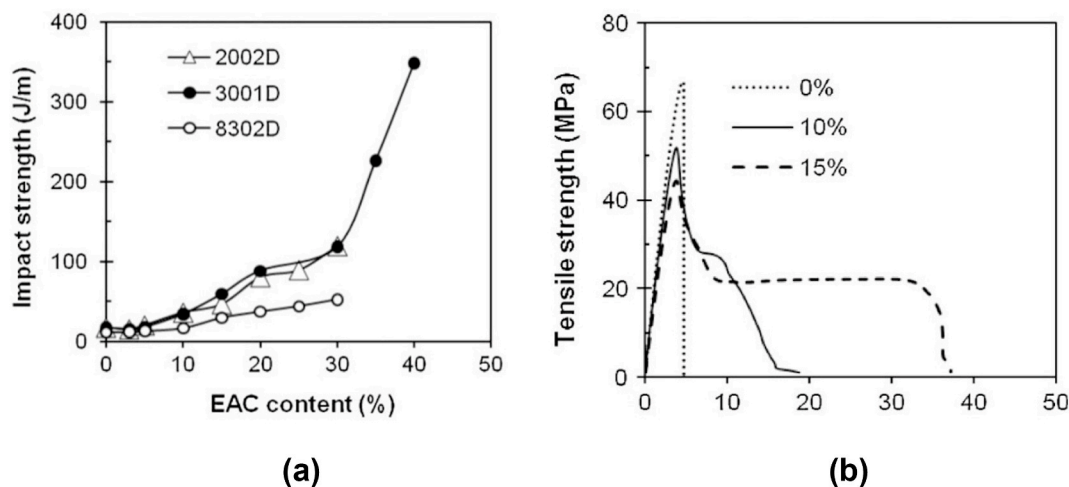

Fig. 24. Impact strength (a) and tensile curve (b) of PLA impact modified with BioMax Strong. EAC refers to the BioMax Strong being an Ethylene-Acetate Copolymer (reprinted from “K.A. Afrifah, L.M. Matuana, Impact modification of polylactide with a biodegradable ethylene/acrylate copolymer, *Macromol. Mat. Eng.*, 295 (2010), 802–811”, Copyright (2010), with the permission from John Wiley and Sons).

Table 5
The most important properties of PBS, PCL, and PLA biopolymers (based on [266–271]).

Property/Material	PBS	PCL	Amorphous PLA	Annealed PLA	PHA	PHB	PHBV	PBAT
Density, g/cm ³	0.9	1.06	1.24	1.29	1.25	1.25	1.25	1.22
Tensile strength, MPa	30	50	59	66	15–40	15–45	18–40	21
Tensile modulus, MPa	1600	400	3750	4150	2000	400–3800	1200–4600	85
Elongation at brake (ε), %	>150%	400	2.2	2.0	1–15	6–27	2.5 to 50	670
Flexural strength, MPa	40	75	106	119	–	–	~62	7.5
Flexural modulus, MPa	1400	2500	3650	4150	–	–	~3300	126
Charpy impact strength (unnotched), kJ/m ²	45	60	20	35	–	–	–	not broken
Charpy impact strength (notched), kJ/m ²	10	22	3	7	–	3	–	–
Glass transition temperature, °C	0	–110	55	55	2	–10 to 15	–10 to 25	–
Melting temperature, °C	165	60	155	155	160–175	153 to 175	145 to 180	115–125
Heat Deflection Temperature (HDT at 0.45 MPa load), °C	65	95	55	120	–	–	105	55
Vicat softening, °C	62	85	53	115	–	53 to 148	143	91
Shrinkage, %	0.8	0.5	0.4	0.4	–	–	–	–

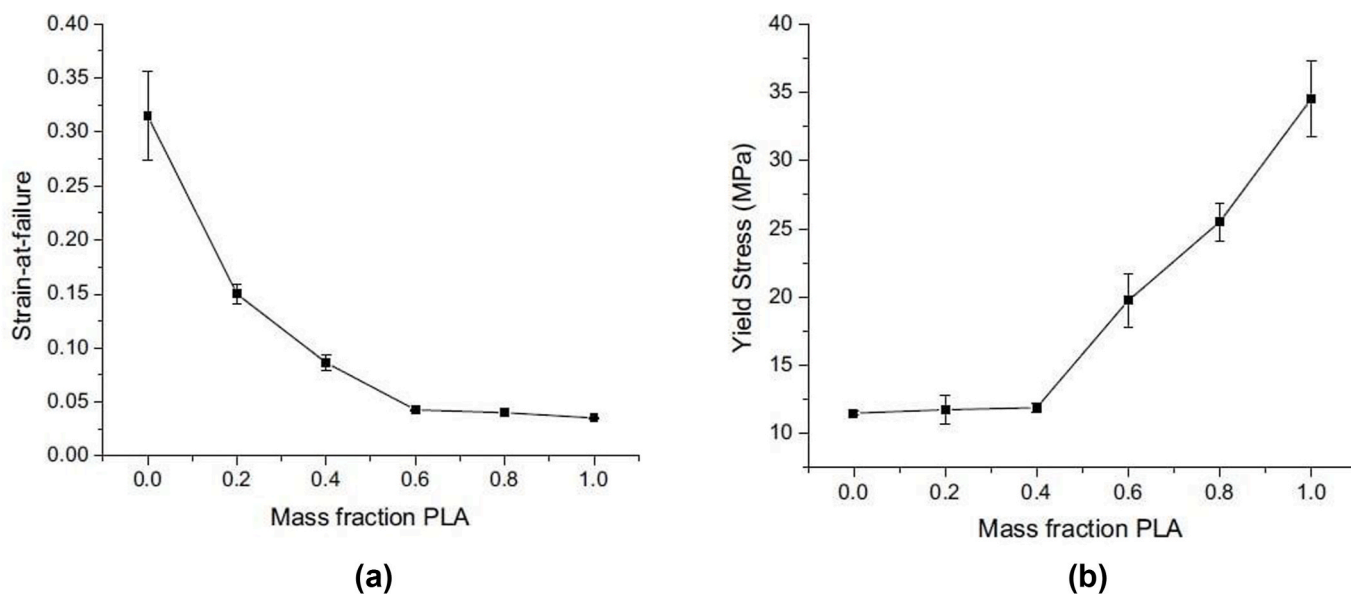

Fig. 25. Elongation at failure (a) and yield stress (b) for PLA/PCL blends (reprinted from “M.E. Broz, D.L. VanderHart, N.R. Washburn, Structure and mechanical properties of poly(D,L-lactic acid)/poly(ε-caprolactone) blends, *Biomaterials*, 24 (2003), 4181–4190”, Copyright (2003), with the permission from Elsevier).

Table 6

Effect of various isocyanates as compatibilizers on the impact strength of 80/20 wt% PLLA/PCL blends [191].

Reactive compatibilizer	Charpy impact strength, kJ/m ²
None	17
L-Lysine Triisocyanate	64
L-Lysine Diisocyanate	Not broken
1,3,5-tris-(6-izocyantohexil)-1,3,5-triazin-2,4,6-trion	58
1,3,5-tris-(6-izocyantohexil)-biuret	30
trimethylolpropane-triglycidil-ether	17

Table 7 contains all the relevant data of the biopolymer blends.

To sum it up, using an inherently tough biopolymer to increase the impact properties of PLA is the best way to keep the final blend “green”. However, the phases in PLA-based biopolymer blends are incompatible. At the same time, some moderate improvements in impact and strain properties can still be achieved without compatibilizing agents. The toughness of PLA-based biopolymer blends can be significantly increased without compatibilization with the appropriate ratio of the phases; In the right ratio, they develop a co-continuous phase. Finally, annealing can also be a powerful way to increase toughness by exploiting the synergistic effect between the crystal structure of PLA and a second, inherently tough phase.

4.4. Copolymerization of PLA-based biopolymer blends

Usually, the disadvantages of a particular polymer can be compensated for by copolymerization. However, in most cases, simply making a polymer blend will not solve the problems since polymer blends as usually not compatible or miscible. In this case, copolymerization is the solution. It can be done in two ways. Either the different monomers are united before polymerization and then polymerized together, or the polymers are combined with the use of an additional reactive compatibilization agent. The former method requires whole polymerization plants (or if performed in laboratories, only small amounts can be produced), while the latter method is a much simpler process, where block or graft copolymers are produced ‘in-situ’ in an extruder during continuous processing. Below we will discuss the latest developments in the copolymerization of PLA.

4.4.1. Copolymerization of PLA/PBS blends

Harada et al. [183] copolymerized a 90/10 wt% PLA/PBS blend by using 0.15 wt% of the reactive processing agent Lysine Triisocyanate (LTI). The authors found that with the addition of LTI, the impact strength of PLA/PBS blends increased from 18 kJ/m² to 60 kJ/m². The 80/20 wt% PLA/PBS blend with LTI did not even break during the impact test. Wang et al. [198] used dicumyl peroxide (DCP) as a reactive compatibilization agent for PLA/PBS blends. They found that the addition of only 0.1 wt% DCP increased the impact strength of the 80/20 wt % PLA/PBS blend from 3.7 kJ/m² to 30.0 kJ/m² and the elongation at break was also higher than 200%. Hu et al. [199] found that elongation at break reached approximately 400% when 1 wt% Poly(Butylene Succinate) (PBS) was added to an 80/20 wt% PLA/PBS blend.

4.4.2. Copolymerization of PLA/PCL blends

Tuba [191] used an LTI processing agent to copolymerize an 80/20 wt% PLA/PCL blend. He found out that the impact strength of the blend increased significantly even when LTI was used in small amounts. Harada et al. [200] also used LTI as a compatibilizer for 80/20 wt% PLA/PCL blends. The impact strength of the blends increased from 2 kJ/m² to 17.3 kJ/m² with the use of 0.5 wt% LTI. Odent et al. [201] investigated the effect of the co-addition of the rubber-like Poly(ϵ -caprolactone-co-lactide) (P(CL-co-LA)) copolymer as an impact modifier and N,N'-Ethylene Bis (12-Hydroxystearamide) (EBS) as nucleating

agent. The authors used 10 wt% (P(CL-co-LA)) and various amounts of EBS between 0 and 5 wt% in 4032D grade PLA with 1.4% D-lactide content. When 10 wt% copolymer was added to PLA, its notched Izod impact strength of 2.7 kJ/m² increased to 11.4 kJ/m². However, when 4 wt% EBS was also added, impact strength further increased to 30.5 kJ/m² (Fig. 26). This could be explained by a strong cross-effect between the impact modifier and the crystalline structure of PLA, as Tábi [160] proved for PLA toughened by EVA.

Wang et al. [202] demonstrated that a PLLA/PCL blend compatibilized with 3.5 phr poly(D-lactide)-poly(ϵ -caprolactone)-poly(D-lactide) (PCDL) exhibited an elongation at break of 43%, compared to 18% of uncompatibilized PLLA/PCL.

4.4.3. Copolymerization of PLA/PBAT blends

Zhang et al. [197] used GMA as a reactive compatibilizer for PLA/PBAT blends. They demonstrated that the addition of 1 wt% GMA to a PLA/PBAT blend containing 30 wt% PBAT, increased the Charpy impact strength from 15 kJ/m² to 32 kJ/m². Zhao et al. [203] found that the addition of 0.75 wt% multifunctional epoxy oligomer reactive compatibilizer to a 60/40 wt% PLA/PBAT blend increased elongation at break and notched impact strength to 579.9% and 29.6 kJ/m², which were 75.3 and 12.3 times that of neat PLA, respectively. Ji et al. [204] added 3 wt% monomethoxy poly(ethylene glycol)-polylactide (MPEG--PLA) di-block copolymer as compatibilizer to a 70/30 wt% PLA/PBAT blend. The addition of MPEG-PLA helps to increase the elongation at break from 30% (uncompatibilized blend) to 296%. Torre et al. [205] used epoxidized and maleinized cottonseed oil (ECSO and MCSO, respectively) to compatibilize a 80/20 wt% PLA/PBAT blend. They obtained maximum elongation at break (about 320%) for the PLA/PBAT blend compatibilized with 7.5 wt% MCSO.

In sum, studies found that compatibilized blends were far tougher than uncompatibilized blends. In most cases, LTI, DCP or GMA is used as a reactive compatibilizing agent in typical amounts of 0.1–1.0 wt%. These were found highly effective in enhancing compatibility between PLA and the second biopolymer phase. An enormous increase in impact strength was achieved, which could not have been achieved without the compatibilizing agents, by simple blending. However, non-green compatibilizers are not the best choice in biopolymer blends. Thus the direction of development is bio-based and biodegradable compatibilizing agents.

4.5. Stretching of PLA at a high temperature

Uniaxial or biaxial stretching of semi-crystalline PLA at temperatures between T_g and T_m influences the structure of the polymer and can therefore help improve the mechanical performance of PLA without any additives [206–212]. The strain-hardening behavior of PLA is explained by the molecular orientation and the transformation of the crystal structure that occurs during drawing. The deformation behavior of stretched PLA is primarily the result of a synergetic effect of the stretching temperature and strain rate. Thus the α' -form crystals, which usually develop when PLA is crystallized below 120 °C, can be transformed to the more ordered α -form crystals when PLA is uniaxially drawn in the temperature range between 80 °C and 90 °C [207]. Hsu et al. [208] proved that at the drawing below 80 °C, the α' - α transformation did not occur, although crystallinity and the degree of deformation greatly improved. Sawai et al. [209] demonstrated that α -form crystals gradually transform into β -form crystals, and the relative amount of the β -form crystals increases with increasing drawing temperature from 80 °C to 140 °C reaching a maximum (~0.8) at 130 °C. The authors also proved that the amount of β -form crystals increases with increasing M_w of PLA. Takahashi et al. [213] showed that increasing strain rate (draw rate) increases the stress and improves the uniformity of the drawing of PLA. The influence of the strain rate on the ductility of PLA is more complex. Thus the draw ratio of PLA increased gradually from 1 to 3 as the strain rate was increased from 0.5 to

Table 7
Properties of biopolymer blends.

PLA used	second bio-polymer phase used	Amount of second phase, wt%	Max. X _c of PLA, %	Results	Comment	Ref.
4032D, Natureworks, l-lactide content not shown (M _w = -)	G4460 EnPol, Ire Chemicals (M _w = -)	0, 10, 20, 50, 80, 90, 100	-	σ = 42 MPa, E = 800 MPa (20 wt % PBS)	Elongation at break of blends is quite similar to neat PLA	[179]
4032D, Natureworks, l-lactide content 98.6% (M _w = 94.000 g/mol)	EnPol G4560-M, Ire Chemicals, (M _w = 88.000 g/mol)	0, 20, 40, ..., 100	16% (20 wt% PBS)	σ = 45 MPa, E = 1200 MPa (20 wt % PBS)	Crystallinity increases up to 20 wt% PBS content	[180]
- , Korea Inst of Sci and Tech. D-lactide content not shown (M _w = 367.000 g/mol)	- , Saehan Industries (M _w = 120.000 g/mol)	0, 10, ..., 100	41.6 (10 m% PBS)	PBS component was expelled out of the interlamellar regions of PLA (Small-angle X-ray)	Less than 30 wt% PBS large number of small spherulites	[174]
LACEA, Mitsui Chemicals, D-lactide content not shown (M _w = 350.000 g/mol)	GsPLA, Mitsubishi Chemical (M _w = 150.000 g/mol)	5, 10, 20, 100	-	Crystallization peak intensity increases with increasing PBS content (DSC, cooling curve)	Applied 0.5 wt% thermal stabilizer (Ciba Irganox 1010, Ciba Irgafos 168)	[175]
3051D, Natureworks, D-lactide content not shown (M _w = -)	- , Mitsubishi Chemical (M _w = -)	0, 10, 20, ...50, 100	50.8% (50 wt% PBS)	σ = 40 MPa, E = 1200 MPa (20 wt % PBS)	Immiscible and exhibited phase separation	[176]
EcoPLA, Cargill, D-lactide content not shown (M _w = -)	B1001 Bionolle B3010 Bionolle, Showa Highpolymer Co Ltd. (M _n = - g/mol)	5, 10, 20, ..., 50	43.97 (40 wt% B3010 PBS)	-	-	[177]
2002D, Natureworks, l-lactide content <0.3% (M _n = 100.000 g/mol)	Bionelle 1001, Showa Highpolymer Co Ltd. (M _n = 60.000 g/mol)	20, 30, ..., 80	-	G' dynamic storage modulus shows the phase inversion point of the blend at 50 wt% PBS	Elongated fibrous structure of the discrete phase (PBS 40 wt%)	[178]
4032D, Natureworks, l-lactide content - (M _n = -)	- , Anqing Hexing Chemical (M _n = -)	0,10, 20,30, 40, 60, 80, 100	23.8% (10 wt % PBS)	Thermal stability of PLA/PBS (60/40 wt%) is higher compared to the neat PLA	Tg of PLA decreased when content of PBS increased	[272]
2032D, Natureworks, l-lactide content not shown (M _w = -)	GS Pla FZ91PD, Mitsubishi Chemical (M _w = -)	0, 40, 50, 60, 100	31.95% (40 wt% PBS+ Sb 0.1 phr)	σ = 38 MPa, ε = 3%, Energy at break = 0.5 J (40 wt% PBS)	Nucleating agents: Sodium benzoate (SB), calcium carbonate (NPCC201)	[273]
4032D, Natureworks, l-lactide content - (M _n = -)	B1001 MD Bionolle ,Showa Highpolymer Co Ltd. (M _n = -)	10, 30, 50, 70, 90, 100	23.8% (10 wt % PBS)	5 wt% calcium sulfate whiskers effect heterogenous nucleation	Phase separation at 50 wt% PBS content	[181]
2002D, Natureworks, D-lactide content 4% (M _w = 235 kg/mol)	3001 Bionolle, Showa Highpolymer Co Ltd. (M _w = 190 kg/mol)	10, 30, 40, 50	39.5 (30 wt% PBS+6 wt% TPP)	E = 2300 MPa, ε = 20%, Impact energy = 11.4 kJ/m ² (30 wt% PBS+2 wt% TPP)	Compatibilized blends showed improved toughness	[182]
40529 PLA, Toyota Motors, D-lactide content: - (M _n = -)	1020 Showa Highpolymer Co Ltd (M _n = -)	0, 10, 20, 100+ lysine triisocyanate (LTI),	-	Impact strength increased 2–4 times that of PLA (10 wt% PBS+0.15 wt% LTI)	Isocyanate as reactive processing agent	[183]
Lacty 5000, Shimadzu Co Ltd., D-lactide content: - (M _w = 145.000 g/mol)	GS Pla AZ PBSL, Mitsubishi Chemical (M _w = 147.000 g/mol)	0, 10, 20, 30, 100	46.7 (30 wt% PBS)	σ = 45 MPa E = 1540 MPa, ε = 90%, (30 wt% PBS)	Phase-separated system with the dispersed PBSL phase having a spherical shape	[184]
LACEA H-100 PLLA, Mitsubishi Chemical, D-lactide content: - (M _w = -)	GS Pla AZ PBSL, Mitsubishi Chemical (M _w = 147.000 g/mol)	0, 1, 5, 10, 20, 40, 60, 80, 100	12.0 (10 wt% PBSL)	σ = 58 MPa E = 2500 MPa, ε = 180%, (10 wt% PBSL)	Higher elongation at break than PBS	[185]
LACEA H-100 PLLA, Mitsubishi Chemical, D-lactide content: - (M _w = -)	1020 Bionolle, PBS Showa Highpolymer Co Ltd (M _w = -)	0, 1, 5, 10, 20, 40, 60, 80, 100	18.6 (10 wt% PBS)	σ = 65 MPa E = 2800 MPa, ε = 100%, (10 wt% PBS)	Decreasing Tg ΔT = 2 °C	[185]
-PLLA, BoehringerIngelheim, D-lactide content: - (M _n = 180.000 g/mol)	3001 Bionolle, PBSA Showa Highpolymer Co Ltd (M _n = 46.000 g/mol)	0, 20, 40, 60, 80, 100	-	-	Two independent T _g	[186]
PLA, Polysciences D-lactide content: - (M _w = 100.000 g/mol)	PCL, Aldrich (M _w = 80.000 g/mol)	0, 20, 40, 60, 80, 100	-	σ = 25 MPa E = 2000 MPa, ε = 5%, (20 wt% PCL)	Morphology changing at 50 above wt% PLA content	[187]
4042D PLA, Natureworks D-lactide content: - (M _w = - g/mol)	6400 Capa PCL, Perstorp (M _w = -g/mol)	0, 50, 100	-	σ = 29 MPa E = 800 MPa, ε = 7%, (50 wt% PCL)	Incompatible blend	[188]
PLA, - D-lactide content: - (M _w = - g/mol)	PCL, - (M _w = -g/mol)	0, 10, 20, 30	25.53 (10 wt % PCL)	-	Degree of crystallinity of PLA decreasing increasing PCL content	[274]
2002D PLA, Natureworks D-lactide content: 4% (M _w = - g/mol)	6500 Capa, Southern Chemicals in	0, 30, 50, 70, 100 (+1, 3, 5 wt% TiO2)	-	-	TiO2 improved the thermal stability of PLA	[275]

(continued on next page)

Table 7 (continued)

PLA used	second bio-polymer phase used	Amount of second phase, wt%	Max. X _c of PLA, %	Results	Comment	Ref.
2002D PLA, Natureworks D-lactide content: 4% (M _w = - g/mol)	Joannesburg (M _w = -g/mol) 6500 Capa, Southern Chemicals in Joannesburg (M _w = -g/mol)	0, 30, 50, 70, 100 (+1, 3, 5 wt% TiO ₂)	-	-	PCL glass transition peaks increased using TiO ₂	[276]
2002D PLA, Natureworks D-lactide content:- (M _w = - g/mol)	TONE-787 Dow/Union Carbide (M _w = -g/mol)	20 (3 phr glycidyl methacrylate GMA)	-	GMA good monomeric compatibilizer	Electron-beam irradiation process improved the interfacial adhesion	[189]
Lacty 9030, PLA Shimadzu Co Ltd. D-lactide content:- (M _w = - g/mol)	CelgreenH7 Daicel Chemistry Ind. Co Ltd. (M _w = -g/mol)	15	-	Dramatic improvement of the mode I fracture energy	used lysine trisocanate (1 wt%)	[190]
4042D PLA, Natureworks D-lactide content: 4% (M _w = - g/mol)	PCL, Sigma Aldrich (M _w = 70.000–90.000 g/mol)	20 (+0, 2.5, 5.0, 7.5, 10 phr PEG-PPG)	-	σ = 25 MPa E = 1400 MPa, ε = 74.4%, (20 wt% PCL+7.5 PEG-PPG)	polyethylene glycol (PEG), Polypropylene glycol (PPG)	[192]

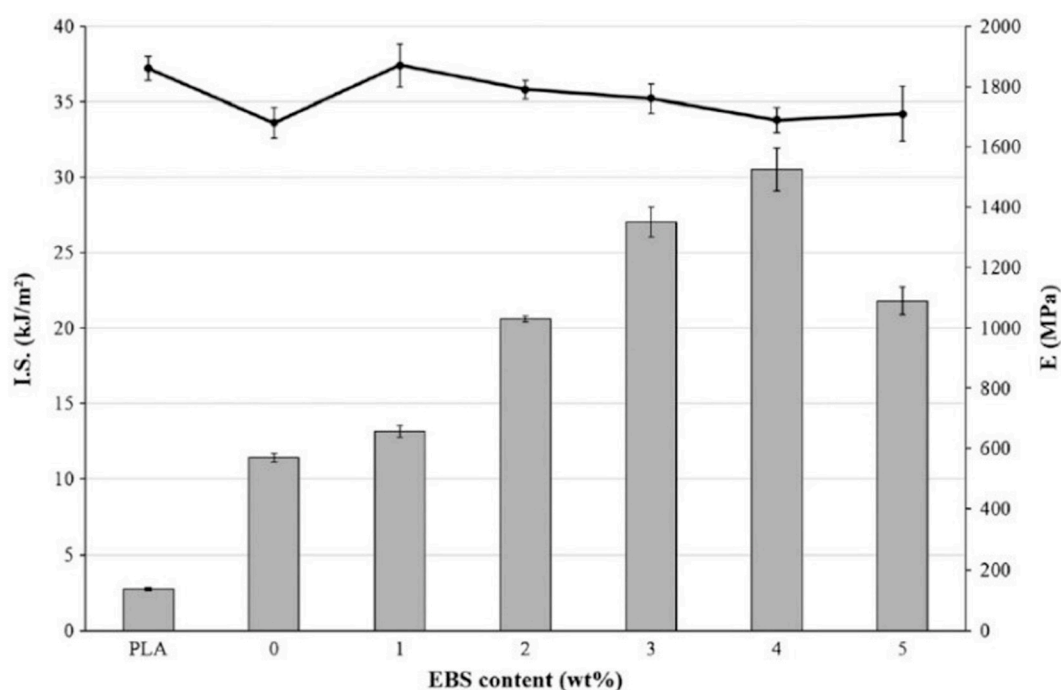

Fig. 26. Notched Izod impact strength (I.S.) and elasticity modulus (E) of PLA with 10 wt% of P(CL-co-LA) copolymer and various EBS nucleating agent content (reprinted from “J. Odent, J.-M. Raquez, P. Leclère, F. Lauro, P. Dubois, Crystallization-induced toughness of rubber-modified polylactide: combined effects of biodegradable impact modifier and effective nucleating agent, Polym. Adv. Tech., 26 (2015), 814–822”, Copyright (2003), with the permission from John Wiley and Sons).

50/min. However, a further increase of the strain rate reduces the ductility of PLA.

Stam et al. [206] proposed a schematic representation of the deformation-induced formation of superstructure (molecular orientation and crystallization) as well as morphology change (cavitation) in amorphous PLA at various strain rates (Fig. 27). To exclude the effect of temperature on crystal formation, they chose a drawing temperature of 75 °C, at which the crystallization of PLA is severely depressed. The authors suggested that during drawing, the structure of PLA develops in three stages. In the first stage, when the stretching strain is lower than 100%, the molecular chains start to be oriented in one direction, and some regions of amorphous PLA start to crystallize. In the range of strain from 100% to 160%, the orientation of polymer molecules further progresses while some of the crystals start to break, and therefore cavities are formed. When stretching strain exceeds 160%, the polymer molecules get disentangled, and thus, more oriented chains are formed

in the amorphous region, which promotes the further crystallization of PLA.

Although it is believed that the most important factors that improve the crystallization of drawn PLA are stretching temperature and strain rate, several recent studies [211,214,215] have proved that the D-lactide content can also have a significant influence on stretching-induced crystallinity. Chen et al. [214] showed that the elongation at break of PLA increased to 145%, 175%, and 190% at the pre-stretching ratio of 0.5 for PLA with 2%, 4%, and 12% D-lactide content, respectively, which is 26–33 times greater than that of undrawn PLA. Tábi et al. [215] also demonstrated that the tensile behavior of PLA films exposed to uniaxial deformation greatly differs due to the difference in D-lactide content. The crystallinity of 1.4% D-lactide content PLA films increased from 5–6% to 45–47%, and that of 4.3% D-lactide content PLA from 1–2% to 33–36%, as a result of elevated temperature stretching. Tábi et al. [215] investigated the effect of the annealing of unstretched PLA films, with

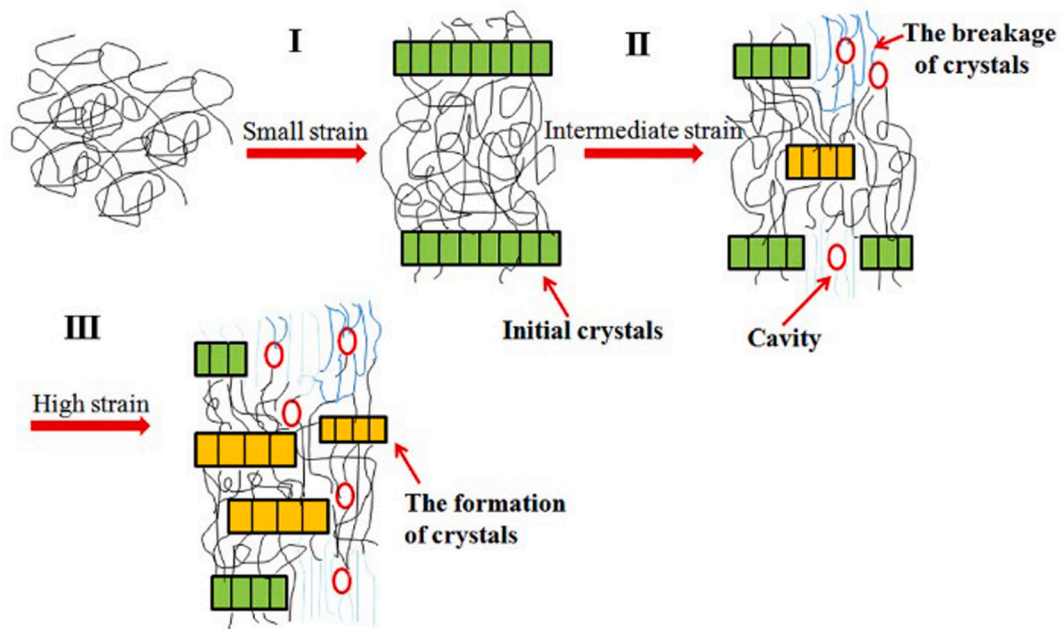

Fig. 27. Schematic representation of structure evolution of amorphous PLA at different strain rates (reprinted from “X. Zhang, K. Schneider, G. Liu, J. Chen, K. Bruning, D. Wang, M. Stamm, Structure variation of tensile-deformed amorphous poly(L-lactic acid): Effects of deformation rate and strain, *Polymer*, 52 (2011), 4141–4149”, Copyright (2011), with the permission from Elsevier).

the same thermal history as stretched films. They annealed the unstretched films for about 2 min, and they stretched the other set of films at a high temperature for the same time. They found that the effect of annealing (only the influence of temperature), was much smaller than the effect of stretching at elevated temperatures. This means that the increase in the crystallinity of PLA films was the result of a synergetic effect of stretching and an elevated temperature.

To sum up, uniaxial and biaxial stretching at high temperatures has been proved to be an effective method of improving the ductility and crystallinity of PLA without additives and thus it is a very important technique in blow molding.

5. Methods to increase the HDT of PLA

Since the HDT of injection-molded PLA product (with the use of general processing parameters, like a mold temperature of 20–40 °C) is around 50–60 °C. It needs to be increased so that PLA products can be used in more engineering applications. There are basically two routes to increase the HDT of PLA parts. The first adding reinforcements. In this case, high reinforcement content should be used to improve the lowest modulus (the lowest value is found above T_g but before cold crystallization takes place) to an acceptable level (Fig. 7). Usually, this means a high reinforcement content of at least 40 wt% even with the use of rigid fibers, like basalt. This possibility is discussed in Section 6. There are two other methods to increase the HDT of PLA. The first one is post-production crystallization (PPC), or annealing, where the final part is put into a heat chamber for crystallization. The disadvantage of this method is that the part will first deform due to shrinkage, released residual stresses, changing density, and low modulus, and then this deformed shape will be fixed as a crystalline structure develops. Another possibility is to use efficient nucleating and/or stereocomplex agents and create this crystalline structure during production by in-mold crystallization (IMC) with a mold temperature above the T_g of PLA. The disadvantage of this method is increased cycle time. In our literature review, we focused on using nucleating agents and stereocomplexation of PLA.

5.1. Nucleation

Crystallinity plays an essential role in the HDT of PLA. The crystalline structure, including the crystallization rate and the overall crystallinity (or crystalline ratio) of PLA, is highly dependent on its D-lactide content and M_w . The lower the D-lactide content, the higher the crystallization rate (and the price of PLA). The rule of thumb is that with every wt% of D-lactide, the time needed for complete crystallization increases by 40–45%. The dependency of crystallinity on M_w can be seen in Fig. 28.

The ability of semi-crystalline thermoplastics to crystallize is characterized by the crystallization half-time ($t_{1/2}$) (Fig. 29 (a)), referring to the time needed to develop half the possible maximum crystallinity (Fig. 29 (b)). Naturally, the lower $t_{1/2}$ is, the faster crystallization is. As can be seen in Fig. 29 (a), for a conventional PLA with 1–4% D-lactide

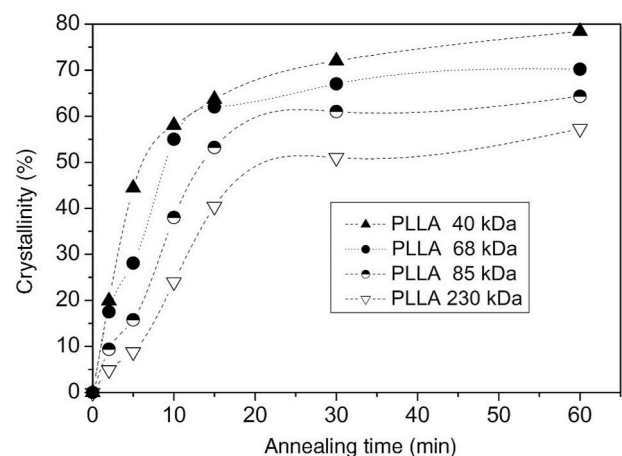

Fig. 28. The crystallinity of PLLA grades with various M_w (reprinted from “R. Auras, L.T. Lim, S.E.M. Selke, H. Tsuji, *Poly(Lactic Acid): Synthesis, Structures, Properties, Processing, and Applications*, John Wiley & Sons, Inc., Hoboken, New Jersey, USA, 2010”, Copyright (2010), with the permission from John Wiley and Sons).

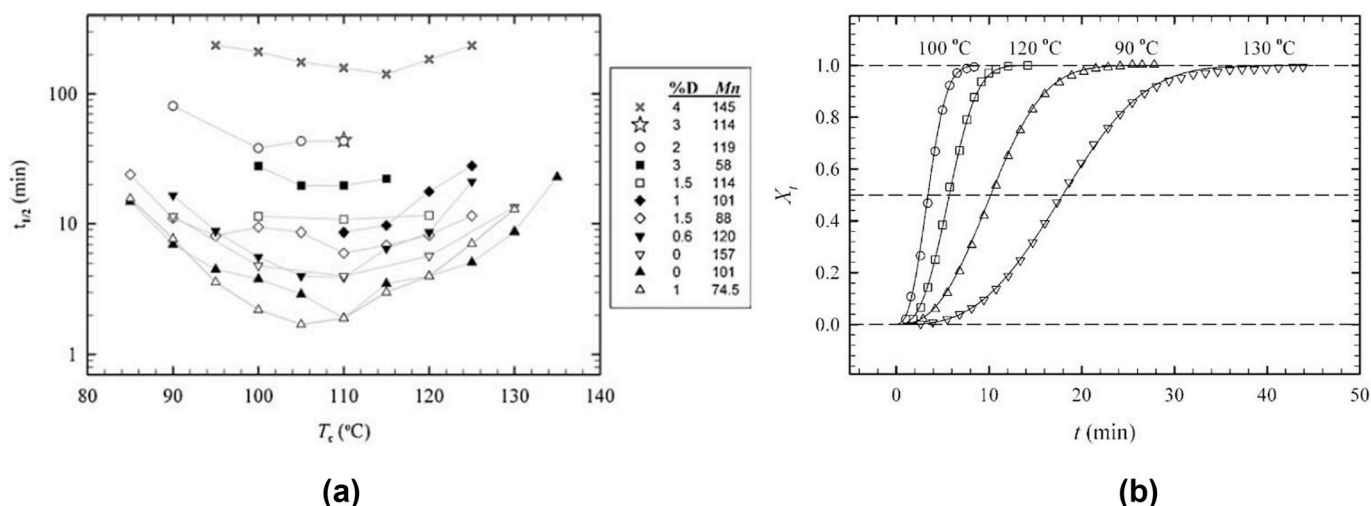

Fig. 29. Crystallization half-time of PLA with various M_w and D-lactide content as a function of crystallization temperature (a) and relative crystallinity in the function of time and temperature (b) (reprinted from “S. Saiedlou, M.A. Huneault, H. Li, C.B. Park, Poly(lactic acid) crystallization, Prog. Polym. Sci., 37 (2012), 1657–1677”, Copyright (2012), with the permission from Elsevier).

content, this value is a few minutes, and even the lowest value is around 2–3 min (PLLA), which is still unacceptably long for rapid processing technologies, like injection molding.

As it was demonstrated, the overall crystallization rate of PLA during homogeneous crystallization is relatively low. At the same time, nucleating agents produce nuclei, which start to grow before they could appear from the homogenous melt. Nucleating agents can decrease $t_{1/2}$ dramatically (below 2 min). These nucleating agents can be physical or chemical. Physical nucleating agents can be categorized into mineral, organic and mineral-organic hybrids. A considerable number of single nucleating agents have been tested for PLA (Table 8) (in decreasing order of the number of papers found and in alphabetical order if the same number of papers were found). In some cases, two or more nucleating agents were used simultaneously (Table 9).

There are numerous papers in the literature focusing on the nucleation of PLA. However, it is difficult to compare these results because various PLA grades (with various M_w and D-lactide content), various amounts of nucleating agents, and various measurement conditions (cooling rate for non-isothermal mode and crystallization temperature for isothermal mode) were used. Nevertheless, we selected the most effective nucleating agents based on crystallization temperature (T_c , °C) (the higher the better), and crystallization half-time (the shorter the better) (Table 10). The literature analysis showed that the most effective nucleating agents were Zinc PhenylPhosphonate (PPZn), Ecopromote and Ecopromote HD (commercially available nucleating agents for PLA).

Finally, we also investigated the combined use of nucleating agents and plasticizers, and found that these materials have a positive synergistic effect on crystallinity. The crystallization of a polymer shows a bimodal aspect because in the higher temperature range, it is driven by the growth of the nucleus, while in the lower temperature range, it is driven by nucleation (appearing of a nucleus). The combined use of nucleating agents and plasticizers enhances both low and high-temperature driving forces, since nucleating agents promote the appearance of nuclei in the high-temperature range (when the driving force for homogenous nucleation is weak), while plasticizers promote the growth of nuclei in the low-temperature range (when it is hindered by the lack of chain mobility). Li and Huneault [38] examined the combined use of Talc (nucleating agent) and PEG (plasticizer). They demonstrated the positive synergistic effect between these two additives on the crystallization of PLA (Fig. 30).

In sum, effective nucleating agents promote the crystallization of PLA during cooling from melt starting in the 120–130 °C temperature

range and have a crystallization half time of a minute or less, opening the possibility of in-mold crystallization for a continuous injection molding cycle with an increased, but reasonable cycle time.

5.2. Stereocomplexation

By melt mixing semi-crystalline PLLA and PDLA grades, a special crystalline structure, a so-called stereocomplex can develop [22–24,32, 33,216–228]. Stereocomplex crystallites typically exhibit a T_m of 220–230 °C, which is 50 °C higher than that of PLLA and PDLA. Moreover, the stereocomplex crystallization rate is faster than that of homocrystallization. Thus, PLA parts can crystallize even without further heterogeneous nucleating agents. Stereocomplexation improves mechanical performance and HDT [229], hydrolytic/thermal degradation resistance [230], and gas barrier properties [226]. The stereocomplex crystal structure most effectively forms when around 50 wt% of PLLA is blended with about 50 wt% of PDLA, and either PLLA or PDLA has low M_w (one order of magnitude lower than the M_w of the other type of PLA). Thus the crystal structure is highly dependent on the optical purity (thus the L-lactide and D-lactide content) of PLLA and PDLA (Fig. 31) as well as on M_w .

As Fig. 31 shows, if the PLA grades to be blended contain more than 10% D-isomers, the blended PLA can only be amorphous. For stereocomplex crystallization, both enantiomers must have high optical purity. Other variations such as homocrystals and amorphous regions, or stereocomplex, homocrystals, and amorphous regions, can also develop if PLA grades with suitable isomer contents are chosen.

As for the M_w aspect, simply melt mixing high molecular weight PLLA and PDLA is not likely to promote stereocomplex crystallization. The maximum threshold M_w for stereocomplexation is dependent on processing: If PLA is produced from melt its M_w is around 6 000 g/mol, while it increases to 40,000 g/mol and 400,000 g/mol in the case of solution casting and precipitation, respectively [33]. Thus, by increasing M_w , stereocomplexation is hindered by the homocrystallization of PLLA and PDLA. To promote stereocomplex crystallization, stereoblock PLA, a block polymer of PLLA and PDLA, can also be used produced by either solid-state polycondensation of the mixture of medium molecular weight PLLA and PDLA, or the stepwise ring-opening polymerization of D- and L-lactides.

If a stereocomplex crystalline structure is successfully developed, another peak appears during a DSC heating scan around 230 °C, which is related to the melting of the stereocomplex crystallites (the homocrystallites may also melt around 180 °C for PLLA) [217].

Table 8
Single nucleating agents used for PLA.

Nucleating agent	Reference
Talc	[277–292]
Multiwalled carbon nanotubes and derivatives	[293–300]
Hydrazide compounds	[301–306]
PDLA	[216,282,286,307,308]
Ethylene-Bis-Stearamide compounds	[278,301,309–311]
Montmorillonite derivatives	[286,295,312–314]
Multiamide compound (TMC-328)	[315–319]
Phenylphosphonate derivatives including zinc, calcium, barium, zirconium phenylphosphonates (PPZn, PPCa, PPBa, PPZr)	[282,312,320–325]
Polyhedral oligomeric silsesquioxane derivatives (POSS)	[326–331]
Starch or thermoplastic starch and derivatives	[284,286,332–334]
Cellulose derivatives	[286,335–338]
Graphene or graphite oxide derivatives	[339,340]
P-tert-butylcalixarene (TBC) based compounds (TBC8-eb, TBC8-t)	[279,341]
Titanium Dioxide (TiO ₂) derivatives	[342,343]
Aromatic Phosphonate (commercialized under trade name EcoPromote)	[344]
Alumina (Al ₂ O ₃)	[345]
Amide ammonium acetate organic vermiculite	[346]
Barium Sulfate (BaSO ₄)	[342,347]
Bisurea compounds	[348]
Cadmium phenylmalonate	[349]
Calcium Carbonate (CaCO ₃)	[342]
Carbon black derivatives	[350]
Cashew gum	[351]
Cellulose nanocrystals	[352]
Cellulose nanocrystal-g-PLLA	[353,354]
Cellulosic fibers and Poly(Ethylene Glycol) (PEG)	[355]
Chitin, chitosan	[286]
Clay nanoparticles	[356]
Cyanuric acid	[357]
Dilithium Hexahydrophthalate (HHPA-Li)	[358]
Fluorohectorite	[313]
Fullerene	[286]
Fulvic acid amide	[359]
Fulvic acid – thiourea amide derivative grafted polystyrene	[360]
Graphene nanosheet	[361,362]
Graphene oxide	[363]
Guanine, adenine, cytosine, thymine	[287]
HNT	[56]
Immersion into acetone	[364]
Multiamide compound (TMC-300)	[365]
Kraft lignin	[366]
LAK-301 (Commercially available nucleating agent for PLA)	[56,367]
Mixture of PPZn (15%) and Zinc Oxide (ZnO) (85%)	[323]
Multi-branched PLA	[368]
Myo-inositol	[369]
Nanoclay, nanosilica	[290]
Nanocrystalline hydroxyapatite	[370]
N-Aminophthalalimide compound (NA-S)	[371]
NT-20 (commercial nucleating agent)	[292]
Nucleating agent for PET	[316]
Nucleator consisting of aluminium complex of phosphoric ester and hydrotalcite (NA)	[289]
N,N'-bis(2-hydroxyethyl)terephthalamide	[372]
Octamethylenedicarboxylic di(2-hydroxybenzohydrazide)	[373]
Organosolv lignin	[366]
Orotic Acid	[367,374]
Oxalamide based organic compound	[375]
PEG-grafted-graphene oxide	[376]
Poly(Ethylene Glycol) (PEG)	[41,50]
Polyglycolide	[377]
Phtalimide	[378]
Rectonite	[379]
Uracil	[287]
Sepiolite	[312,313]
Silicon Dioxide (SiO ₂)	[295]
Sodium benzoate	[288]

Table 8 (continued)

Nucleating agent	Reference
Star-structured PLLA	[224]
Talc	[56,366,367,380]
TMP-5	[367]
TMC-306	[367]
Xylan propionate, butyrate	[381]
Zinc citrate derivatives	[283]
α-cyclodextrin complex	[382]

Table 9

Two or more nucleating agents used for PLA at the same time.

Nucleating agent	Ref.
PDLA and Talc	[286,383]
Talc and PEG	[38,285,292]
EBHSA and Talc	[305]
NT-20 + PEG	[292]
NT-20 + PEG + EBS	[292]
NT-20 + PEG + Talc	[292]
PBS + Talc	[384]
PDLA and Aromatic Phosphonate (Ecopromote)	[343]
PDLA and Aromatic Phosphonate (Ecopromote) and PEG	[343]
PDLA and fullerene; montmorillonite	[286]
PDLA and Nucleator consisting of an aluminium complex of phosphoric ester and hydrotalcite (NA)	[289]
1,3:2,4-dibenzylidene D-sorbitol (DBS) and PEG	[383]

Table 10

The most effective nucleating agents for PLA.

Nucleating agent	Crystallization temperature (T _c), °C	Crystallization half-time (t _{1/2}), min	Reference
TBC8-eb	134	1.6	[279]
TBC8-t	133	no data	[341]
Zinc PhenylPhosphonate (PPZn)	130	0.6	[341]
Zinc Citrate Complex (ZnCC)	126	0.8	[283]
Uracil	122	1.0	[287]
Talc	107	0.6	[278]
PDLA	135	1.3	[308]
Hydrazide compound	131	no data	[301]
OMBH	120	0.6	[305]
TMC-306	131	no data	[306]
TMC-328	128	1.3	[319]
Aromatic phosphonate (Ecopromote)	127	no data	[344]
NT-20 (commercial nucleating agent)	119	no data	[292]
Cadmium phenylmalonate	128	no data	[349]
Orotic Acid	124	0.7	[385]
EBS	no data	0.8	[310]
Xylan butyrate	94	0.8	[381]
Xylan propionate	110	1.0	[381]
PDLA with Talc	139	no data	[286]
PDLA with EcoPromote	128	no data	[344]
PDLA with EcoPromote and PEG	129	no data	[344]
Talc with PEG	105	0.9	[386]
EBHSA with Talc	120	1.0	[305]
Long-chain branched PLA with DBS and PEG	123	0.6	[383]
NT-20 with PEG	122	no data	[292]
NT-20 with PEG and EBS	120	no data	[292]
NT-20 with PEG and Talc	120	no data	[292]

A “full” stereocomplex develops when an equimolar (or close to equimolar) PLLA and PDLA blend is produced as indicated by one melting peak around 230 °C, while in other blending ratios a mixture of stereocomplexes and homocrystals develop indicated by two melting

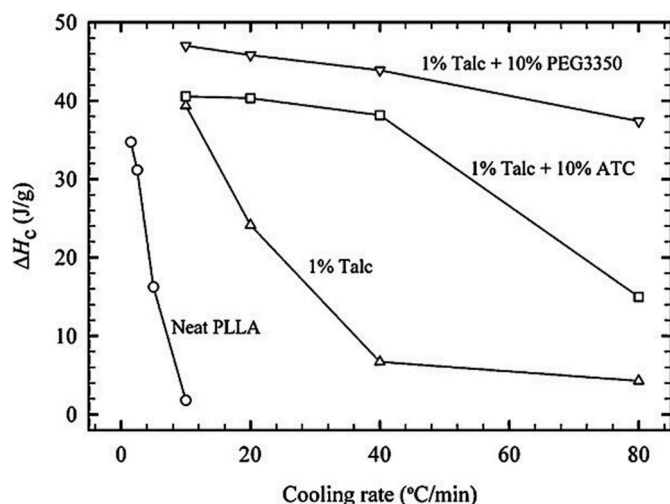

Fig. 30. Crystallinity as a function of cooling rate for various nucleated PLA materials) (reprinted from “S. Saeidlou, M.A. Huneault, H. Li, C.B. Park, Poly (lactic acid) crystallization, Prog. Polym. Sci., 37 (2012), 1657–1677”, Copyright (2012), with the permission from Elsevier).

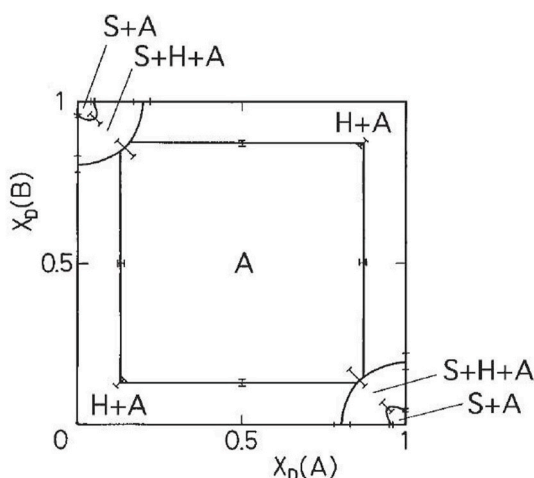

Fig. 31. Amorphous (A), stereocomplex crystalline (S), and homocrystalline (H) phases in 50-50 wt% PLA blends. XD (A and B) represents the D-lactide ratio for the A and B PLA used for blending (reprinted from “H. Tsuji, Poly(lactide) stereocomplexes: formation, structure, properties, degradation, and applications, Macromol. Biosci., 5 (2005), 569–597”, Copyright (2005), with the permission from John Wiley and Sons).

peaks around 230 °C and 180 °C. Naturally, pure PLLA or PDLA will only give one homocrystal melting peak [23].

Several studies [24,219,220,231] proved that the crystallization behavior of a PLLA/PDLA blend depends on the melt state (processing). PLLA and PDLA chains preserve their interactions like a “melt memory” effect, and thus this heterogeneous melt crystallizes easily, while at higher temperatures or longer residence times, a homogenous melt develops, which prevents stereocomplex crystallization. Narita et al. [24] analyzed the crystallization behavior of a 10 wt% PDLA/90 wt% PLLA blend prepared by simple melt extrusion. They found that stereocomplex crystallization is highly dependent on the state of the stereocomplex crystallites, and thus on the processing temperature. Since stereocomplex crystallites melt in the range of 211–227 °C, the melted and recrystallized stereocomplex crystals crystallize in the temperature range of 228–238 °C and have the strongest nucleation effect, while at higher temperatures, crystallization upon cooling does not occur (Fig. 32).

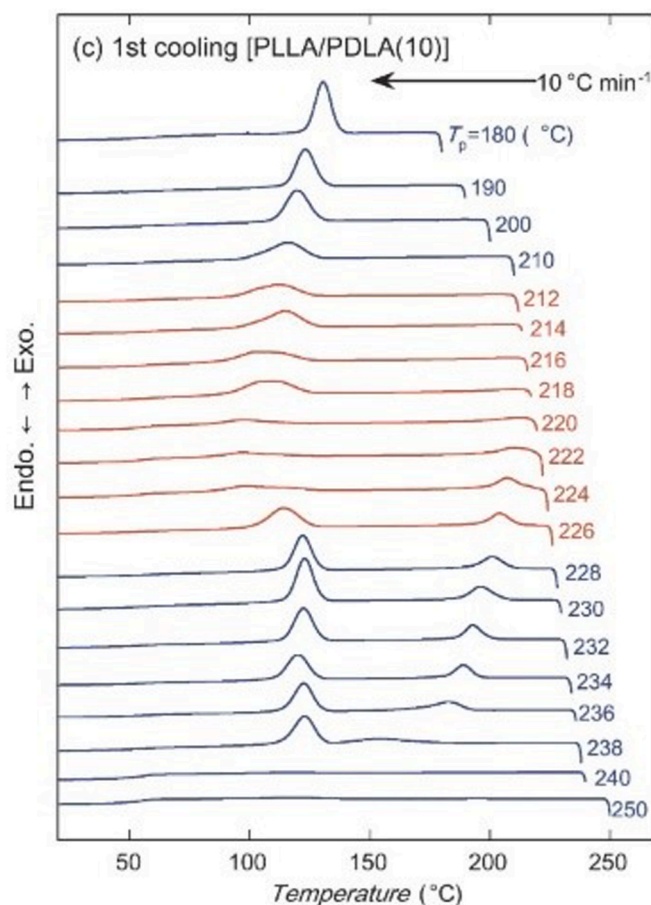

Fig. 32. Crystallization upon cooling from various processing temperatures (T_p). Red lines represent the cooling curves started within the melting range of the stereocomplex crystallites (reprinted from “J. Narita, M. Katagiri, H. Tsuji, Highly enhanced nucleating effect of melt-recrystallized stereocomplex crystallites on poly(L-lactic acid) crystallization, Macromol. Mat. Eng., 296 (2011), 887–893” Copyright (2011), with the permission from John Wiley and Sons). (For interpretation of the references to colour in this figure legend, the reader is referred to the Web version of this article.)

Yamane and Sasai [220] demonstrated that when a 95 wt% PLLA/5 wt% PDLA solution blend was heated up to 200 °C and cooled, stereocomplex crystals acted as a nucleating site for PLLA. At the same time, when the blend was heated up to 240 °C and cooled, no nucleation was observed.

Rahman et al. [216] proved that pre-crystallized PLLA/PDLA films at 100 °C show a much faster crystallization rate from melt than the cast and not crystallized films (Fig. 33), supporting the statement that the thermal history of stereocomplex formation affects the overall crystallization rate even when the stereocomplex is melted.

Srithep et al. [232] injection-molded 50/50 wt% PLLA/PDLA blends skipping twin-screw extrusion and feeding the PLLA and PDLA pellets directly into the hopper of the injection molding machine. Compounding stereocomplex PLA is difficult, due to the increased melt viscosity, but without twin-screw extrusion, the stereocomplexation of PLA occurred in the barrel of the injection molding machine. By setting the melt temperature in the right range where stereocomplexation can occur, they produced crystalline PLA specimens with surprisingly high elongation at break (>150%) (Fig. 34).

At 200 °C, it was possible to produce a highly crystalline PLA sample, while at 230 °C, crystallinity decreased as the temperature was not optimal for stereocomplexation.

Finally, the efficiency of stereocomplexation can also be increased by the addition of biodegradable poly(butylene adipate-co-terephthalate)

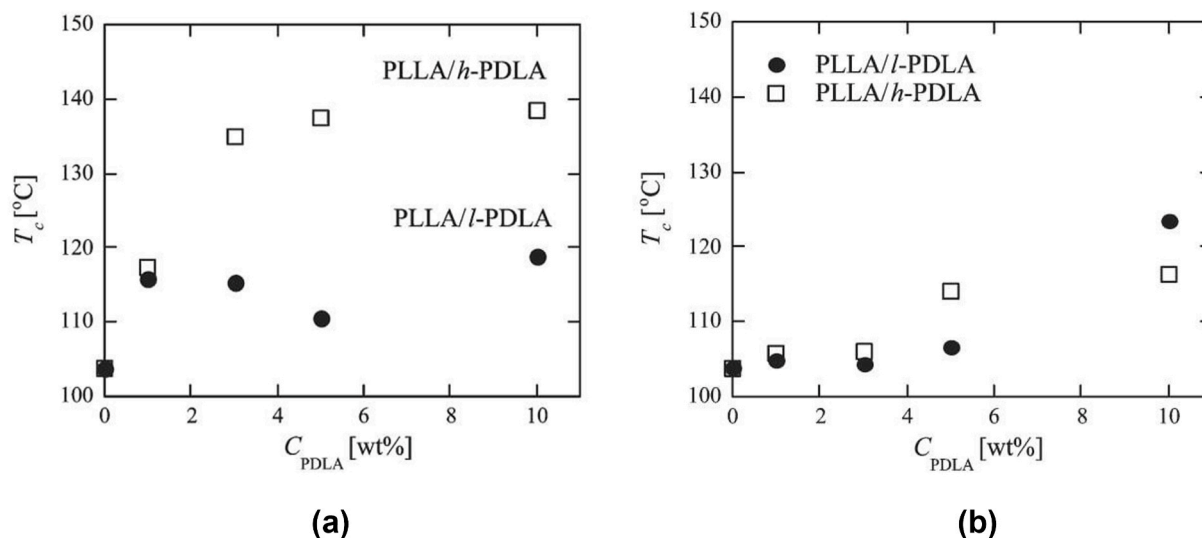

Fig. 33. Crystallization temperature as a function of PDLA content with high ($M_w = 228000$) and low ($M_w = 30800$) molecular weight for pre-crystallized (at 100 °C) (a) and not crystallized (b) samples (reprinted from “N. Rahman, T. Kawai, G. Matsuba, K. Nishida, T. Kanaya, H. Watanabe, H. Okamoto, M. Kato, A. Usuki, M. Matsuda, K. Nakajima, N. Honma, Effect of polylactide stereocomplex on the crystallization behavior of poly(L-lactic acid), *Macromolecules*, 42 (2009), 4739–4745”, Copyright (2009), with the permission from American Chemical Society).

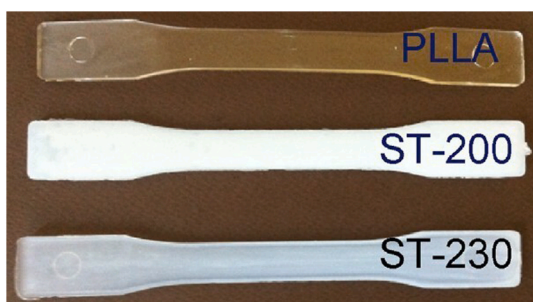

Fig. 34. PLLA and stereocomplex PLA (mixture of 50/50 wt% of PLLA and PDLA) injection molded with a barrel temperature of 200 °C and 230 °C (reprinted from “Y. Srithep, D. Pholharn, Lih-ShengTurng, O. Veang-in, Injection molding and characterization of polylactide stereocomplex, *Polym. Deg. Stab.*, 120 (2015), 290–299” Copyright (2015), with the permission from Elsevier).

to a PLLA/PDLA blend during low temperature (190 °C) extrusion [233].

In sum, the following parameters influence stereocomplexation from melt:

- Optical purity of PLLA and PDLA (L and D-lactide content, respectively).
- The blending ratio of PLLA and PDLA (deviation from equimolar blending).
- M_w of PLLA and PDLA.
- Annealing (time and temperature) of the PLLA/PDLA blend to develop a stereocomplex before processing.
- Properly selected processing (melt) temperature not to “overmelt” the stereocomplex.

Finally, the impacts of using stereocomplex PLA are:

- Stereocomplex crystallization rate is faster than that of homocrystallization. Thus, PLA parts can crystallize even without further nucleating agents (the maximum cooling rate for full crystallization is unknown for stereocomplexes).

- Stereocomplex crystallization is, in most cases, accompanied by homocrystallization of PLLA or PDLA (if the blend is not equimolar).
- Higher cold crystallization rate.
- Higher melt temperature (around 220 °C).
- Better mechanical properties.
- Higher HDT; full stereocomplex PLA has an HDT of around 150 °C.
- Better thermal stability resulting in longer allowable residence time (or temperature) in the barrel of the injection molding machine [223].
- Higher resistance against hydrolytic degradation [225,230].
- The bottleneck of stereocomplexation is still the price of PDLA. However, some Lactobacilli are reported to produce D-lactic acid exclusively.

5.3. Applying the in-mold crystallization method

According to the literature, the HDT of PLA can be improved with fiber reinforcement, by blending, or by increasing crystallinity. The first two options are not discussed in this article because increasing the HDT significantly would require 30–60 wt% stiff synthetic fibers or other polymers needed for reinforcing or blending, which greatly reduce the “green” nature of the final product, although cellulose-based fibers or other biopolymers can also be used. The third and most important option to improve HDT is to develop significant crystallinity during processing. This can be performed with the help of nucleating agents, plasticizers, stereocomplexed PLA, or the combination of these, as well as using a mold temperature higher than T_g . A mold temperature higher than T_g decreases the cooling rate during the cooling phase (until the melt reaches the temperature of the mold) and enables additional annealing after cooling since PLA will crystallize in the mold. In the literature, HDT is only measured a few times, and even fewer papers focus on measuring the HDT of in-mold crystallized injection-molded nucleated PLA parts (Table 11)

In most cases, 110 °C molds were used for annealing nucleated PLA parts within the mold, but the authors still used a rather long annealing time despite the effective nucleating agents used. These annealing times are not the possible shortest annealing times, but the authors simply used these parameters. Nevertheless, it is still evident that the use of nucleating agents or a PLLA/PDLA stereocomplex increased the HDT of pure PLA (55 °C) above 100 °C in most cases, sometimes even to 124 °C. Also, in all cases, HDT B measurement was performed, which applies the

Table 11
Heat deflection temperature of in-mold crystallized PLA parts nucleated with various additives.

PLA used	Nucleating agent	Injection molding temperature/annealing time, °C/min	Heat Deflection Temperature/Method used, °C/A, B or C	Ref.
3001D, NatureWorks, 1.4% D-lactide content	2 wt% Talc	110/4	88/B	[278]
6202D, NatureWorks, D-lactide content not shown (M_w = unknown)	1 wt% EBHSA + 1 wt% Talc	110/6	110/B	[305]
6202D, NatureWorks, D-lactide content not shown (M_w = unknown)	1 wt% OMBH	110/2	124/B	[305]
4032D, NatureWorks, D-lactide content not shown (M_w = unknown)	8 wt%; 25 wt % PDLA	Compression molded	103; 109/B	[310]
70 wt% of 3001D, NatureWorks, 5% D-lactide content (M_w = unknown) in a blend with 20 wt% EMA-GMA and 10 wt% of PEBA	1 wt% LAK-301 + 10 wt % miscanthus fibers	120/1	88/B	[387]

smallest load (0.45 MPa) on the specimens and thus it is the easiest to comply with, even though a great increase in crystallinity is needed to significantly increase the HDT of PLA products.

6. PLA based biocomposites

In the last few decades, due to increasing environmental consciousness, biopolymers effectively entered the field of polymer composites, referred to as biocomposites. A biocomposite can be a reinforced material in a broader understanding of the definition of biocomposite, where either the polymer or the reinforcement is renewable resource-based (or bio-based) and/or biodegradable. The stricter understanding of this definition requires that both the polymer and the reinforcement are bio-based and/or biodegradable. A good example of biocomposites is PLA reinforced with cellulose-based natural plant fibers [33,234,235].

Due to its high strength and stiffness, PLA is in the center of biocomposite research nowadays [33,36,234–236]. Although PLA has some drawbacks, such as low impact strength and low HDT, these properties can be enhanced with fiber reinforcements. Moreover, if cellulose-based natural plant fibers are used as reinforcement, the resulting composite will be fully bio-based. Unfortunately, the disadvantage of cellulose-based fibers is hydrophilicity, and low decomposition temperature, which makes their processing more complicated [234, 237–241].

The properties of the cellulose-based fibers are influenced by several factors, including composition (cellulose-hemicellulose ratio) or the conditions of cultivation and harvesting (weather, quality of the soil).

Generally, the more the cellulose content, the better the mechanical properties of the given fiber (Table 12) [237–241].

In the literature, jute, kenaf, flax, hemp, and cellulose fibers are used as a reinforcing fiber for PLA most often, and the optimal reinforcement content was found to be around 30 wt% [237–252]. However, with natural fiber reinforcement, one must pay attention to the relatively high natural water content of the fibers, which might degrade PLA hydrolytically during processing. Another problem is the limited processing temperature and residence time due to the quick decomposition of the cellulose and hemicellulose at elevated temperatures (Fig. 35). Moreover, the adhesion between polymer and natural fiber reinforcement is not always adequate [241].

There are many studies on biocomposites processed by compression molding or injection molding [242–244,246–250,252–255]. Both technologies have pros and cons. Although long fibers, rovings, or even fabrics can be processed by compression molding, the residence time at an elevated temperature is relatively long, and only sheet or shell-like products can be produced. On the contrary, complex parts can be manufactured by injection molding, but typically short (chopped) fibers are used. As discussed previously, we focus on injection molded, PLA-based biocomposites.

Bledzki et al. [247,248] give a good overview of cellulose-reinforced, injection-molded PLA biocomposites. The addition of 30 wt% abaca or cellulose fibers improved tensile, flexural and Charpy impact strength (notched) to twice or three times those of pristine PLA (Fig. 36, Fig. 37). Bledzki et al. [248] also found by SEM that the adhesion between cellulose fibers and the PLA matrix was not perfect and needed to be enhanced by surface treatment of the fibers. Improving the adhesion between fiber and polymer further improved the properties of the biocomposite.

Besides cellulose fibers, basalt fibers can also be used. They are volcanic rock-based mineral fibers. These fibers are chemically and biologically inert, and although basalt is not a renewable resource, it can be found in nature all around the Globe in great quantities, therefore basalt fibers are also considered natural [255]. Basalt fibers have better mechanical and thermal properties than cellulose-based plant fibers, meaning that basalt fibers are not susceptible to thermal degradation at the generally applied injection molding temperatures. However, they are brittle and therefore more susceptible to fiber breakage. Tábi et al. [255] used chopped basalt fibers to reinforce-injection molded PLA. They found that basalt highly improved both tensile strength (120 MPa) and flexural strength (185 MPa) as well as tensile modulus (8.5 GPa) and flexural modulus (12 GPa). Notched and unnotched Charpy impact strength also greatly increased from 2.7 kJ/m² to 9 kJ/m², and from 23 kJ/m² to 38 kJ/m², respectively. Tábi et al. [256] also used long basalt fibers. They used 20 wt% 10 mm basalt fibers; as a result, tensile strength increased from 98 MPa to 124 MPa, flexural strength increased from 144 MPa to 182 MPa, while notched impact strength increased from 5.8 kJ/m² to 18.3 kJ/m².

Wang et al. [257] demonstrated that fibers also have a minor nucleating effect on PLA, as it creates a so-called transcrystalline structure around the fiber (Fig. 38). At the same time, this nucleating effect is almost negligible compared to the impact of dedicated nucleating agents. Nevertheless, by enhancing both the stiffness of the part and its crystallinity, both plant-based (cellulose) and mineral-based (basalt) natural fibers can increase HDT.

Finally, we collected all relevant data from studies focusing on injection-molded, PLA-based biocomposites, and summarized them in Table 13.

In most cases, cellulose-based plant fibers produced weak or moderate reinforcing effect, due to the worse mechanical properties of plant fibers compared to rigid, synthetic fibers. The curved shape of plant fibers means they do not have exact orientation, their mechanical properties vary greatly, they are susceptible to thermal degradation and due to their high inherent water uptake, they may degrade PLA during processing. Basalt fibers produced a stronger reinforcing effect.

Table 12
Properties of natural and man-made fibers [240].

Fibers	Cellulose, %	Density, g/cm ³	Diameter, μm	Tensile strength, MPa	Young's modulus, GPa	Elongation at break, %
Coir	32–43	1.15–1.46	100–460	121–220	4–6	15–40
Kenaf	45–57	–	–	930	53	1.6
Oil palm mesocarp	60	–	–	80	0.5	17
Oil palm EFB	65	0.7–1.55	150–500	248	3.2	25
Jute	61–71.5	1.3–1.49	25–200	393–800	13–26.5	1.16–1.5
Sisal	66–78	1.45	50–200	469–700	9.4–22	3–7
Ramie	68.6–76.2	1.55	–	400–938	61.4–128	1.2–3.8
Flax	71	1.5	40–600	345–1500	25.6	2.7–3.2
Hemp	70–74	1.47	25–500	690	70	1.6
RALF	70–82	–	20–80	413–1627	34.5–82.5	1.6
Nettle	86	–	–	650	38	1.7
Cotton	85–90	1.5–1.6	12–38	287–800	5.5–12.6	7–8
E-glass	–	2.55	<17	3400	73	2.5
Kevlar	–	1.44	–	3000	60	2.5–3.7
Carbon	–	1.78	5–7	3400–4800	240–425	1.4–1.8

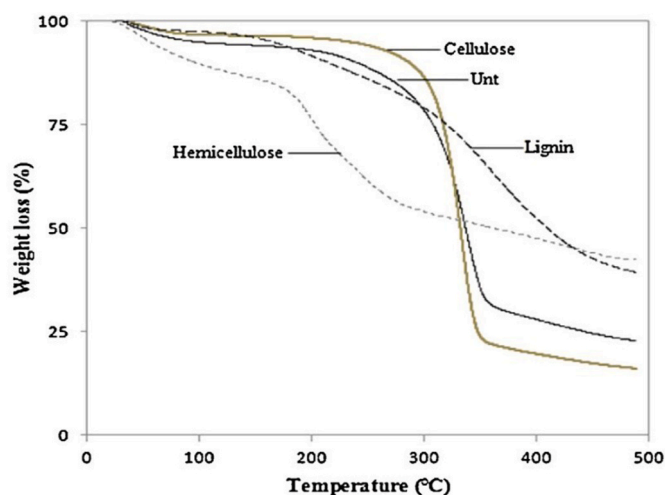

Fig. 35. Decomposition of the components of natural fibers (reprinted from “M. M. Kabir, H. Wang, K.T. Lau, F.Cardona, Effect of chemical treatments of hemp fibre structure, Appl. Surf. Sci., 276 (2013), 13–23”, Copyright (2013), with the permission from Elsevier).

However, basalt fibers alone did not improve HDT significantly, even though the drop in storage modulus above T_g was greatly reduced. With cellulose fibers as reinforcement, the HDT of PLA was in some cases increased to 73 °C due to the joint effect of enhanced crystallinity

(nucleating ability of the fibers) and increased modulus. In-mold crystallization could have increased HDT when biocomposites were injection molded. However, we did not find a single paper on this. Finally, researchers found great potential in using long fiber reinforcements in injection molding. For this, continuous fiber coating extrusion is needed to produce pellets consisting of an inner fiber roving core and an outer PLA coating. After cutting this pre-product to the desired length, they can be injection molded directly as long fiber reinforced pellets; the resulting PLA-based long fiber reinforced injection-molded biocomposite parts have excellent properties.

7. Conclusion

Biopolymer products are increasingly used today instead of “ordinary” plastic products as they are renewable resource-based (bio-based) and inherently biodegradable. These two exceptional properties contribute to protecting our environment and satisfy the requirements of a circular economy. One of the most promising biopolymers is Poly (Lactic Acid) (PLA) due to its availability, moderate price, and good properties.

It is desirable to replace as many petroleum-based plastics with biopolymers as possible, especially with PLA. PLA has good properties (high stiffness and strength), but also two main drawbacks: low impact strength and low Heat Deflection Temperature (HDT) properties. As a result, this replacement is only possible if PLA is modified according to the requirements of the given application. There are several possibilities for modifying PLA, including plasticizing, impact modification, blending, nucleation, stereocomplexation, biocomposite preparation,

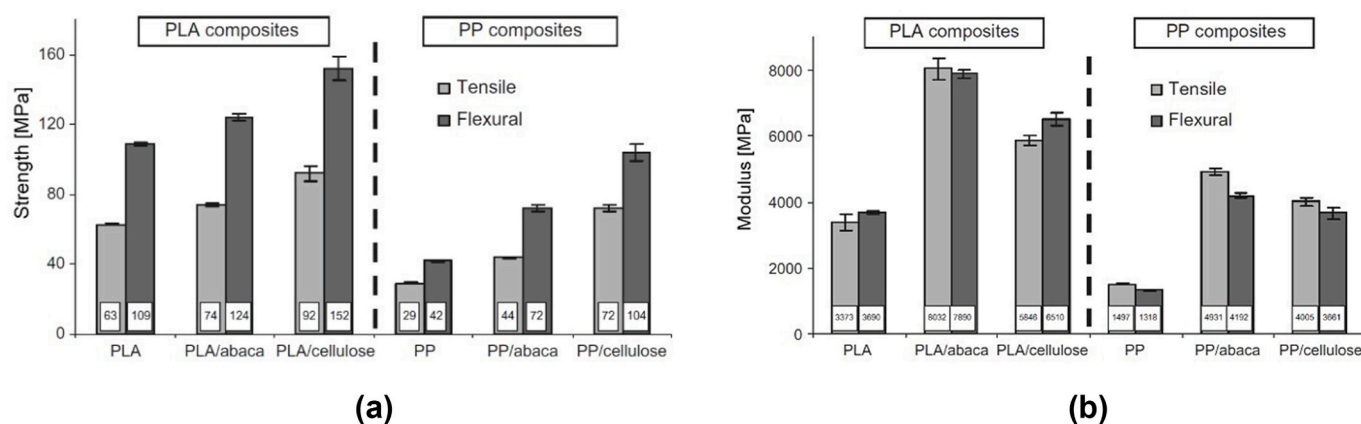

Fig. 36. Strength (a) and modulus (b) of natural fiber reinforced, injection-molded PLA biocomposites (reprinted from “A.K. Bledzki, A. Jaszkievicz, D. Scherzer, Mechanical properties of PLA composites with man-made cellulose and abaca fibres, Compos. Part A Appl. Sci. Manuf., 40 (2009), 404–412”, Copyright (2009), with the permission from Elsevier).

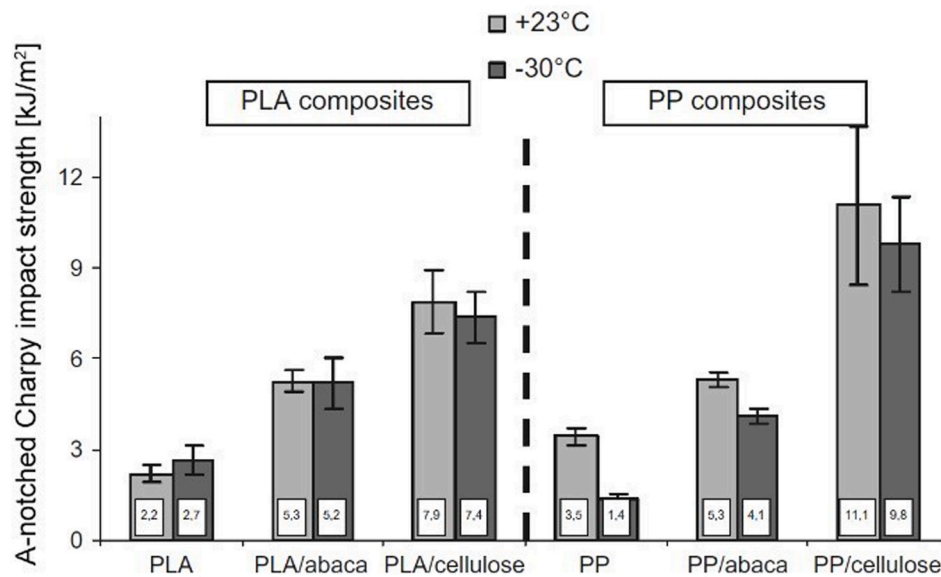

Fig. 37. Charpy impact strength of natural fiber reinforced, injection-molded PLA biocomposites (reprinted from “A.K. Bledzki, A. Jaszkwicz, D. Scherzer, Mechanical properties of PLA composites with man-made cellulose and abaca fibres, *Compos. Part A Appl. Sci. Manuf.*, 40 (2009), 404–412”, Copyright (2009), with the permission from Elsevier).



Fig. 38. Optical micrograph of transcrystalline structure around a natural fiber (reprinted from “Y. Wang, B. Tong, S. Hou, M. Li, C. Shen, Transcrystallization behavior at the Poly(lactic acid)/sisal fibre biocomposite interface, *Compos. Part A Appl. Sci. Manuf.*, 42 (2011), 66–74”, Copyright (2011), with the permission from Elsevier).

and in-mold crystallization. Our goal with this review paper was to present the most effective additives, reinforcing agents, and modification methods used to enhance the HDT and impact properties of injection molded PLA products in the last two decades. Most methods can also be used for other processing technologies as well, but in our review, we concentrated on introducing all these literature results from an injection molding processing point of view. This data, with more than 380 references in this paper, can be used as an effective tool or a manual for PLA processors to bring the properties of PLA close to those of engineering plastics and thus widen its industrial applications. A great deal of research has been performed in the last two decades to find the most suitable additives to increase the HDT and impact properties of PLA (Table 14).

A few of the most suitable additives to increase impact properties are Oligomeric Lactic Acid (OLA) as plasticizer, Natural Rubber (NR) and

Ethylene-Vinyl Acetate (EVA) as impact modifiers, and Poly(Butylene Adipate-co-Terephthalate) (PBAT) or Poly(Butylene Succinate) (PBS) as a second and inherently tough biopolymer phase for blending (with or without reactive compatibilizers like dicumyl peroxide). The most important observation was that the PLA phase must be crystallized (annealed) for maximum impact modification effect, since research shows a toughening mechanism of a positive-cross effect between the crystal structure of PLA and the dispersed and inherently tough impact modifier phase.

The HDT of injection molded PLA products can be increased in two ways (or their combination). One way is to induce crystallization and thus improve crystallinity with the use of a low D-lactide PLA (or PLLA) grade along with effective heterogeneous or stereocomplex (PDLA) nucleating agents like Zinc PhenylPhosphonate (PPZn) or Hydrazide compounds (OMBH, DMBH). At the same time, due to the rapid cooling typically during injection molding, the use of nucleating agents should also be supported by either post-crystallization (PPC) or in-mold crystallization (IMC). Another way to improve HDT is to add additives to PLA that significantly enhance the stiffness of the part (most probably have some nucleating ability as well) so that it can enter the rubbery state at elevated temperatures without major deformation until the product undergoes cold crystallization. These stiffness increasing additives can be talc or natural plant fibers (biocomposite preparation). However, plant fibers have several drawbacks, including high natural water content, high susceptibility to thermal degradation, limited fiber length and fiber content and a curved shape of flexible fibers. These restrict their widespread use in injection molding applications, due to the moderate achievable improvement in properties. At the same time, the possibility is still open for long fiber injection molding (extrusion-coated fiber roving pelletized and fed into the injection molding machine) with natural plant or natural mineral (basalt) fibers. Long fiber injection molding produces much greater improvement in properties than classical short fiber injection molding, as was reported in the literature.

Finally, to sum it up, a crystalline structure and a high level of crystallinity are essential in PLA for a high HDT and good impact modification, but at the same time, one of them can typically only be improved at the expense of the other one. Accordingly, there is no universal solution and HDT and impact properties must usually be balanced and designed according to the given application.

Table 13
Properties of biopolymer composites.

PLA used	Reinforcement type	Amount, wt%	Tensile strength, MPa	Tensile modulus, GPa	Flexural strength, MPa	Flexural modulus, GPa	Charpy impact strength, kJ/m ²		HDT, °C	Crystallinity, %	Ref.
							Notched	Unnotched			
Biomer L9000	kenaf	20	–	–	90	4.5	–	–	–	–	[242]
	rice husk	20	–	–	85	4	–	–	–	–	
3051D PLA, Natureworks	kenaf	20	26	2.3	42	5.5	–	12	–	–	[243]
	kenaf + nanoclay	20 + 3	35	2.4	45	6.2	–	65	–	–	
3051D PLA, Natureworks	kenaf	5, 10, 15, 20	59; 61; 63; 75	3.4; 3.8; 4.1; 5.3	101; 110; 112; 117	4; 5; 5.7; 7	–	26; 17; 16; 12	–	–	[244]
2002D PLA, Natureworks	Cellulose Cordenka 700	25	108	4.2	–	–	8.4	69	–	–	[245]
6202D PLA, Natureworks	flax	10, 20, 30	42.7; 49.2; 54.2	3.9; 5.1; 6.3	–	–	–	10; 10.5; 11.1	–	–	[246]
	Cellulose Cordenka 700	10, 20, 30, 40	50.4; 50.8; 58; -	3.3; 4.0; 4.9; -	–	–	–	43.4; 63; 72.2; 51.3	–	–	
4042D PLA, Natureworks	abaca	30	92	8	–	–	6	–	–	–	[247,
	jute	30	74	9.6	–	–	5	–	–	–	248]
	Cellulose Cordenka 700	30	81.9	5.8	–	–	7.5	–	–	–	
4032D PLA, Natureworks	Cellulose BC200 arboce	10	64.8	4.5	–	–	–	–	–	4	[249]
Biomer L9000	cellulose CreaMix TC 1004	10, 20, 30, 40	61.3; 53.7; 47.3; 39.4	3.2; 4.5; 6.3; 6.8	–; –; 77.7; –	–; –; 6.7; –	–	–	–; –; 73.1; –	–; 48.5; 53.6; 32.2	[250]
	cellulose CreaMix R0083	30, 40	67; 55	6.1; 6.4	82.6; –	6.2; –	–	–	HDT B 72.5; –	43.8; 28.4	2nd heat
	cellulose CreaMix R0084	30, 40	72; 59	6.7; 6.6	76.3; –	6.0; –	–	–	HDT B 73.0; –	40.6; –	2nd heat
3052D PLA, Natureworks	banana/sisal (benzoyl peroxide)	30	79	4.1	125	5.6	–	47.8	–	–	[251]
3251D PLA, Natureworks +30 wt% PHI002 PHA, Natureplast	eucalyptus fibers	10, 20, 30	44; 49; 79	4.3; 5.1; 10	82.5; 89.0; 85.4	4.5; 5.6; 6.4	–	–	49.2; 56; 51.7	–	[252]
									HDT B		
AI1001, PLA eSUN	chopped basalt fiber, (silane treated)	5, 10, 15, 20, 30, 40	70; 80; 90; 100; 120; 123	3.8; 4.2; 5.2, 6.0; 7.6; 8.3	118; 122; 138; 142; 180; 185	4; 5; 6; 7; 10.2; 12.5	3; 5; 6; 6.5; 9; 9.3	23; 26; 28; 30; 38; 38	–; –; –; –; –	4; 14; 18; 19; 19; 19	[255]
									HDT B	1st heat	
Ingeo 3251D (Nature Works LLC)	long basalt fibers (extrudion coated basalt roving)	14.8, 20.4, 25.8	107; 125; 127	4.9; 5.9; 6.5	165; 182; 197	6.3; 7.7; 8.8	16.1; 18.3; 18.7	67.9; 70.1; 68.8	59.2; 60.4; 60.8	2; 5; 10; 1st heat	[256]
PLA 3052-D (Nature Works LLC)	Flax fibers With the silane treatment	7.9; 13.6; 17.6	8.27; 16.68; 30.58	12.2; 16.4; 30.6	–	–	–	–	–	–	[388]
PLA Ingeo™ 3052D (Nature Works)	bleached softwood kraft pulp	40	80.7	6.7	–	–	2.6	16.5	54.1	–	[389]
PLA Ingeo™ 3260HP (Nature Works)	Aloe Vera fibers	30	52.5	~7.2	~90	~7.2	–	–	–	–	[390]
Injection molding grade PLA (Zhejiang Haizheng Biomaterials Co., Ltd., China)	Bamboo fibers	10; 15; 20; 25; 30	~58; 60; 65; 64; 62	–	~97; 94; 93; 89; 87	~4.2; 4.5; 4.8; 5.5; 6.0	~3.4; 3.3; 3.25; 3.2; 3.0	–	–	44.02; 44.19; 40.57; 39.86; 35.69; 48.22	[391]
PLA Ingeo 3052D (Nature Works)	unbleached hardwood kraft pulp fibers	30	73.1	6.4	–	–	–	33.3	–	13.8	[392]
	bleached hardwood kraft pulp fibers	30	79.3	6.5	–	–	–	24.8	–	9.1	
NatureWorks PLA Ingeo 3100HP (NatureWorks)	Sisal fibers	5, 10, 15	~66; 70; 70.7	3.3; 3.7; 4.6	~120; 125; 135.1	n/a; n/a; 5.6	3.28; 3.56; 3.87	–	–	58.4; 61.2; 57.3	[393]
	Flax fibers	20	70.4	~7	–	–	3.7	–	–	34.1	[394]

(continued on next page)

Table 13 (continued)

PLA used	Reinforcement type	Amount, wt%	Tensile strength, MPa	Tensile modulus, GPa	Flexural strength, MPa	Flexural modulus, GPa	Charpy impact strength, kJ/m ²		HDT, °C	Crystallinity, %	Ref.
							Notched	Unnotched			
NatureWorks PLLA and PDLA											
Nature Works PLA 3052 D	Banana fiber	20	~51		~104	–	–	~98	–	17	[395]
Nature Works PLA Ingeo 2003D	Walnut shell	20, 30, 40	38; 36; 36	3.4; 3.3; 3.3	–	–	–	–	–	–	[396]

Table 14

Comparative mechanical properties of pure and modified PLA and petroleum-based engineering plastics (PP and ABS).

Property	PP	ABS	Unmodified PLA	PLA + OLA	PLA + NR		PLA/ EVA	PLA/ PBS	PLA + PPZn				PLA + NF		
													Cellulose	Basalt long fibers	
ref.	[9]	[9]	[78]	[78]	[141]		[151]	[183]	[282]				[250]	[256]	
wt% of an additive, %	–	–	–	15	20	35	40	20	10	2	5	10	15	70	25
Young modulus, GPa	1.2	2.0	2.5	1.3	–	–	–	–	–	1.5	1.6	1.7	1.8	6.7	6.5
Tensile strength, MPa	34.5	41.5	56	21	33	23	20	45	57	56	51	46	44	72.5	128
HDT, °C	67	100	53.5	–	–	–	–	–	–	–	–	–	–	73	61
Elongation at break, %	150	40	4	235	35	225	100	340	220	–	–	–	–	–	–
Impact strength, kJ/m ²	66	300	3	–	8	59	42	64	60	5.9	4.1	3.9	3.5	15	19

Credit authorship contribution statement

Tamás Tábi: Methodology; Writing – original draft; Writing – review & editing; Visualization; Funding acquisition. **Tatyana Ageyeva:** Conceptualization, Writing – original draft; Writing – review & editing; Visualization. **József Gábor Kovács:** Conceptualization, Supervision, Writing – review & editing; Project administration; Funding acquisition.

Declaration of competing interest

The authors declare that they have no known competing financial interests or personal relationships that could have appeared to influence the work reported in this paper.

Acknowledgments

This work was supported by the National Research, Development, and Innovation Office, Hungary (2019-1.1.1-PIACI-KFI-2019-00205, 2019-1.1.1-PIACI-KFI-2019-00335, 2017-2.3.7-TÉT-IN-2017-00049, OTKA FK134336). The research reported in this paper and carried out at BME has been supported by the NRDI Fund (TKP2020 NC, Grant No. BME-NCS) based on the charter of bolster issued by the NRDI Office under the auspices of the Ministry for Innovation and Technology. This paper was supported by the János Bolyai Research Scholarship of the Hungarian Academy of Sciences. The research was supported by the ÚNKP-20-5 New National Excellence Program of the Ministry for Innovation and Technology from the source of the National Research, Development and Innovation Fund.

Abbreviations

ABS – acrylonitrile butadiene styrene
AGM – Acetyl Glycerol Monolaurate
ATB – Acetyl Tributyl Citrate
ATC – Acetyl Triethyl Citrate
CE – Citrate Ester

DBM – Diethyl Bishydroxymethyl Malonate
DBSE – Dibutyl Sebacate
DEA – Diethyl Adipate
DEHP – Diethyl Hexyl Phthalate
DIA – Diisodecyl Adipate
DICD – Di(Isonyl) Cyclohexane-1,2-Dicarboxylate
DMBH – DecaMethylenedicarboxylic diBenzoylHydrazide
DOA – Dioctyl Adipate
DOTP – Dioctyl Terephthalate
DSC – Differential Scanning Calorimeter
EAC – Ethylene-Acrylate Copolymer
EBS – N,N'-Ethylene Bis (12-HydroxyStearAmide)
EGMA – Poly(Ethylene-Glycidylmethacrylate)
EKO – epoxidized karanja oil
ELO – Epoxidized Linseed Oil
ELO – Epoxidized linseed oil
ELO – Epoxidized Linseed Oil
EMA-GMA – Ethylene Methyl Acrylate Glycidyl Methacrylate
ENR – epoxidized NR
EPO – Epoxidized Palm Oil
EPSO – Epoxidized Palm and Soybean Oil mixture
ESO – Epoxidized Soybean Oil
EVA – Ethylene-Vinyl Acetate
GM – Glucose Monoester
GMA – Glycidylmethacrylate
GTA – Glycerol Triacetate (also known as Triacetine)
HDT – Heat Deflection Temperature
IMC – In-mold crystallization
IR – Isoprene Rubber
ISDO – Isosorbide Dioctoate
LDPE – Low Density Polyethylene
M_w – molecular weight
NOL – N-Octyl Lactate
NR – Natural Rubber
OMBH – OctaMethylenedicarboxylic diBenzoylHydrazide
OBGA – Mixture of GTA and Oligomeric Poly(1,3-Butylene Glycol)

	Adipate)
OLA	– Oligomeric lactic acid
OME	– Oligomeric Malonate Esteramide
P(CL-co-LA)	– Poly(ϵ -caprolactone-co-lactide)
PA	– polyamide
PBA	– Poly(1,3-Butylene Adipate)
PBAT	– Poly(Butylene Adipate-co-Terephthalate)
PBOH	– Poly(1,3-Butanediol)
PBS	– Poly(Butylene Succinate)
PBSA	– Poly(Butylene Succinate-co-Adipate)
PBSL	– Poly(Butylene Succinate-co-L-Lactate)
PC	– polycarbonate
PCL	– Poly(ϵ -Caprolacton)
PDEA	– Poly(Diethylene Adipate)
PEA	– Poly(Ethylene Adipate)
PEBA	– PolyEther Block Amide
PEG	– Poly(ethylene glycol)
PEGA	– Reactive blended Poly(Ethylene Glycol MonoAcrylate)
PEGCA	– Poly(Ethylene Glycol-co-Citric Acid) copolymer
PEPG	– Poly(Ethylene Glycol-co-Propylene-Glycol) copolymer
PHA	– Poly(HydroxyAlkanoate)
PHB	– Poly(Hydroxy Butyrate)
PHBV	– Poly(Hydroxy Butyrate-co-Valerate)
PHMA	– Poly(Hexamethylene Adipate)
PHO	– Poly(HydroxyOctanoate)
PLA	– Poly(lactic acid)
PMDO	– Lactic acid and Ethylene Oxide copolymer
PP	– Polypropylene
PPC	– Post production crystallization
PPG	– Poly(propylene glycol)
PVA	– Poly(Vinyl Acetate)
TBC	– Tributyl Citrate
TEC	– Triethyl Citrate
TEC	– Triethyl Citrate
T_g	– glass transition temperature
T_m	– melting temperature
TPP	– Triphenyl Phosphate
VA	– Vinyl Acetate
X_c	– crystallinity
ϵ_b	– elongation at break

References

- [1] M.L. Di Lorenzo, R. Androsch (Eds.), *Industrial Applications of Poly(lactic Acid)*, Springer International Publishing, 2018.
- [2] W.S. Chow, E.L. Teoh, J. Karger-Kocsis, Flame retarded poly(lactic acid): a review, *Express Polym. Lett.* 12 (2018) 396–417.
- [3] K. Madhavan Nampoothiri, N.R. Nair, R.P. John, An overview of the recent developments in polylactide (PLA) research, *Biores, Technol.* 101 (2010) 8493–8501.
- [4] F.-L. Jin, R.-R. Hu, S.-J. Park, Improvement of thermal behaviors of biodegradable poly(lactic acid) polymer: a review, *Compos. B Eng.* 164 (2019) 287–296.
- [5] S. Farah, D.G. Anderson, R. Langer, Physical and mechanical properties of PLA, and their functions in widespread applications — a comprehensive review, *Adv. Drug Deliv. Rev.* 107 (2016) 367–392.
- [6] Bioplastics market data 2019, European Bioplastics Global Production Capacities of Bioplastics 2019–2024, 2019.
- [7] D. Rusus, S.A.E. Boyer, M.F. Lacrampe, P. Krawczak, Bioplastics and vegetal fiber reinforced bioplastics for automotive applications, in: S. Pilla (Ed.), *Handbook of Bioplastics and Biocomposites Engineering Applications*, John Wiley & Sons, 2011, pp. 397–449.
- [8] <https://www.plasticsinsight.com/resin-intelligence/resin-prices/polylactic-acid/>, Poly(lactic Acid) Properties, Production, Price, Market and Uses, in: <https://www.plasticsinsight.com/resin-intelligence/resin-prices/polylactic-acid/>, 2020.
- [9] K. Hamad, M. Kaseem, M. Ayyoob, J. Joo, F. Deri, Poly(lactic acid) blends: the future of green, light and tough, *Prog. Polym. Sci.* 85 (2018) 83–127.
- [10] D.-F. Li, X. Zhao, Y.-W. Jia, L. He, X.-L. Wang, Y.-Z. Wang, Simultaneously enhance both the flame retardancy and toughness of poly(lactic acid) by the cooperation of intumescent flame retardant and bio-based unsaturated polyester, *Polym. Degrad. Stabil.* 168 (2019) 108961.
- [11] M. Shah Mohammadi, M.N. Bureau, S.N. Nazhat, 11 - polylactic acid (PLA) biomedical foams for tissue engineering, in: P.A. Netti (Ed.) *Biomedical Foams for Tissue Engineering Applications*, Woodhead Publishing 2014, pp. 313–334.
- [12] S. Liu, S. Qin, M. He, D. Zhou, Q. Qin, H. Wang, Current applications of poly(lactic acid) composites in tissue engineering and drug delivery, *Compos. B Eng.* 199 (2020).
- [13] M.A. Tehrani, A. Akbari, M. Majumder, Poly(lactic acid) (PLA) layered silicate nanocomposites, in: J.K. Pandey, K.R. Reddy, A.K. Mohanty, M. Misra (Eds.), *Handbook of Polymer Nanocomposites. Processing, Performance and Application*, Springer, 2014, pp. 53–67.
- [14] S. Domenek, C. Courbneau, V. Ducruet, Characteristics and applications of poly(lactide), in: S. Kalia, L. Averous (Eds.), *Biopolymers: Biomedical and Environmental Application*, Wiley, NY, 2011, pp. 183–223.
- [15] A. Díaz-Álvarez, L. Jiao-Wang, C. Feng, C. Santistue, Energy absorption and residual bending behavior of biocomposites bumper beams, *Compos. Struct.* 245 (2020) 112343.
- [16] P. Pan, Y. Inoue, Polymorphism and isomorphism in biodegradable polyesters, *Prog. Polym. Sci.* 34 (2009) 605–640.
- [17] W. Hoogsteen, A.R. Postema, A.J. Pennings, G.T. Brinke, P. Zugenmaier, Crystal structure, conformation, and morphology of solution-spun poly(L-lactide) fibres, *Macromolecules* 23 (1990) 634–642.
- [18] S. Sasaki, T. Asakura, Helix distortion and crystal structure of the R-form of poly(L-lactide), *Macromolecules* 36 (2003) 8385–8390.
- [19] J. Puiggali, Y. Ikada, H. Tsuji, L. Cartier, T. Okihara, B. Lotz, The frustrated structure of poly(L-lactide), *Polym* 41 (2000) 8921–8930.
- [20] D. Sawai, K. Takahashi, A. Sasashige, T. Kanamoto, S.-H. Hyon, Preparation of oriented β -form poly(L-lactide) by solid-state Coextrusion: effect of extrusion variables, *Macromolecules* 36 (2003) 3601–3605.
- [21] L. Cartier, T. Okihara, Y. Ikada, H. Tsuji, J. Puiggali, B. Lotz, Epitaxial crystallization and crystalline polymorphism of polylactides, *Polym* (2000) 41.
- [22] H. Tsuji, Poly(lactide) stereocomplexes: formation, structure, properties, degradation, and applications, *Macromol. Biosci.* 5 (2005) 569–597.
- [23] H. Tsuji, Y. Ikada, Stereocomplex formation between enantiomeric Poly(lactic acid)s. 9. Stereocomplexation from melt, *Macromolecules* 26 (1993) 6918–6926.
- [24] J. Narita, M. Katagiri, H. Tsuji, Highly enhanced nucleating effect of melt-recrystallized stereocomplex crystallites on poly(L-lactide) crystallization, *Macromol. Mater. Eng.* 296 (2011) 887–893.
- [25] T. Kawai, N. Rahman, G. Matsuba, K. Nishida, T. Kanaya, M. Nakano, H. Okamoto, J. Kawada, A. Usuki, N. Honma, K. Nakajima, M. Matsuda, Crystallization and melting behavior of poly(L-lactide), *Macromolecules* 40 (2007) 9463–9469.
- [26] J. Zhang, K. Tashiro, H. Tsuji, A.J. Domb, Disorder-to-order phase transition and multiple melting behavior of poly(L-lactide) investigated by simultaneous measurements of WAXD and DSC, *Macromolecules* 41 (2008) 1352–1357.
- [27] P. Pan, W. Kai, B. Zhu, T. Dong, Y. Inoue, Polymorphic crystallization and multiple melting behavior of poly(L-lactide): molecular weight dependence, *Macromolecules* 40 (2007) 6898–6905.
- [28] J. Zhang, H. Tsuji, I. Noda, Y. Ozaki, Structural changes and crystallization dynamics of poly(L-lactide) during the cold-crystallization process investigated by infrared and two-dimensional infrared correlation spectroscopy, *Macromolecules* 37 (2004) 6433–6439.
- [29] J. Zhang, H. Tsuji, I. Noda, Y. Ozaki, Weak intermolecular interactions during the melt crystallization of poly(L-lactide) investigated by two-dimensional infrared correlation spectroscopy, *J. Phys. Chem.* 108 (2004) 11514–11520.
- [30] P. Pan, B. Zhu, W. Kai, T. Dong, Y. Inoue, Polymorphic transition in disordered poly(L-lactide) crystals induced by annealing at elevated temperatures, *Macromolecules* 41 (2008) 4296–4304.
- [31] T. Tábi, S. Hajba, J.G. Kovács, Effect of crystalline forms (α' and α) of poly(lactic acid) on its mechanical, thermo-mechanical, heat deflection temperature and creep properties, *Eur. Polym. J.* 82 (2016) 232–243.
- [32] S. Saeidlou, M.A. Huneault, H. Li, C.B. Park, Poly(lactic acid) crystallization, *Prog. Polym. Sci.* 37 (2012) 1657–1677.
- [33] R. Auras, L.T. Lim, S.E.M. Selke, H. Tsuji, *Poly(Lactic Acid): Synthesis, Structures, Properties, Processing, and Applications*, John Wiley & Sons, Inc., Hoboken, New Jersey, USA, 2010.
- [34] H. Liu, J. Zhang, Research progress in toughening modification of poly(lactic acid), *J. Polym. Sci. B Polym. Phys.* 49 (2011) 1051–1083.
- [35] R.M. Rasal, A.V. Janorkar, D.E. Hirt, Poly(lactic acid) modifications, *Prog. Polym. Sci.* 35 (2010) 338–356.
- [36] L.T. Lim, R. Auras, M. Rubino, Processing technologies for poly(lactic acid), *Prog. Polym. Sci.* 33 (2008) 820–852.
- [37] Z. Grigale, M. Kalnins, A. Dzene, V. Tupureina, Biodegradable plasticized Poly(lactic acid) films, *Sci. J. of Riga Tech. Uni.* 21 (2010) 97–102.
- [38] H. Li, M.A. Huneault, Effect of nucleation and plasticization on the crystallisation of poly(lactic acid), *Polym* 48 (2007) 6855–6866.
- [39] O. Martin, L. Averous, Poly(lactic acid): plasticization and properties of biodegradable multiphase systems, *Polym* 42 (2001) 6209–6219.
- [40] Z. Kulinski, E. Piorkowska, Crystallization, structure and properties of plasticized poly(L-lactide), *Polym* 46 (2005) 10290–10300.
- [41] Y. Hu, Y.S. Hu, V. Topolkariev, A. Hiltner, E. Baer, Crystallization and phase separation in blends of high stereoregular poly(lactide) with poly(ethylene glycol), *Polym* 44 (2003) 5681–5689.
- [42] Y. Byun, Y.T. Kim, S. Whiteside, Characterization of an antioxidant poly(lactic acid) (PLA) film prepared with α -tocopherol, BHT and poly(ethylene glycol) using film cast extruder, *J. Food Eng.* 100 (2010) 239–244.

- [43] M.P. Arrieta, M.D. Samper, J. López, A. Jiménez, Combined effect of poly (hydroxybutyrate) and plasticizers on polylactic acid properties for film intended for food packaging, *J. Polym. Environ.* 22 (2014) 460–470.
- [44] C. Courgneau, S. Domenek, A. Guinault, L. Avérous, V. Ducruet, Analysis of the structure-properties relationships of different multiphase systems based on plasticized poly(lactic acid), *J. Polym. Environ.* 19 (2011) 362–371.
- [45] Y. Hu, M. Rogunova, V. Topolkarav, A. Hiltner, E. Baer, Ageing of Poly(lactide)/Poly(ethylene glycol) blends. Part 1. Poly(lactide) with low stereoregularity, *Polym* 44 (2003) 5701–5710.
- [46] Y. Hu, Y.S. Hu, V. Topolkarav, A. Hiltner, E. Baer, Aging of poly(lactide)/poly (ethylene glycol) blends. Part 2. Poly(lactide) with high stereoregularity, *Polym* 44 (2003) 5711–5720.
- [47] F. Hassouna, J.-M. Raquez, F. Addiego, P. Dubois, V. Toniazzo, D. Ruch, New approach on the development of plasticized polylactide (PLA): grafting of poly (ethylene glycol) (PEG) via reactive extrusion, *Eur. Polym. J.* 47 (2011) 2134–2144.
- [48] C. Courgneau, O. Vitrac, V. Ducruet, A.-M. Riquet, Local demixion in plasticized polylactide probed by electron spin resonance, *J. Magn. Reson.* 233 (2013) 37–48.
- [49] G. Ozkoc, S. Kemalolu, Morphology, biodegradability, mechanical, and thermal properties of nanocomposite films based on PLA and plasticized PLA, *Appl. Polym. Sci.* 114 (2009) 2481–2487.
- [50] M. Pluta, Morphology and properties of polylactide modified by thermal treatment, filling with layered silicates and plasticization, *Polym* 45 (2004) 8239–8251.
- [51] Z. Kulinski, E. Piorowska, K. Gadzinowska, M. Stasiak, Plasticization of Poly(L-lactide) with Poly(propylene glycol), *Biomacromolecules* (2006) 2128–2135.
- [52] E. Piorowska, Z. Kulinski, A. Galeski, R. Masiek, Plasticization of semicrystalline poly(L-lactide) with poly(propylene glycol), *Polym* 47 (2006) 7178–7188.
- [53] S. Jacobsen, H.G. Fritz, Plasticizing polylactide – the effect of different plasticizers on the mechanical properties, *Polym. Eng. Sci.* 39 (1999) 1303–1310.
- [54] A. Greco, A. Maffezzoli, S. Forleo, Sintering of PLLA powders for rotational molding, *Thermochim. Acta* 582 (2014) 59–67.
- [55] Z. Jia, J. Tan, C. Han, Y. Yang, L. Dong, Poly(ethylene glycol-co-propylene glycol) as a macromolecular plasticizing agent for polylactide: thermomechanical properties and aging, *J. Appl. Polym. Sci.* 114 (2009) 1105–1117.
- [56] X. Shi, G. Zhang, T.V. Phuong, A. Lazzeri, Synergistic effects of nucleating agents and plasticizers on the crystallization behavior of poly(lactic acid), *Molecules* 20 (2015) 1579–1593.
- [57] I. Pillin, N. Montrelay, Y. Grohens, Thermo-mechanical characterization of plasticized PLA: is the miscibility the only significant factor? *Polym* 47 (2006) 4676–4682.
- [58] M. Baiardo, G. Frisoni, M. Scandola, M. Rimelen, D. Lips, K. Ruffieux, E. Wintermantel, Thermal and mechanical properties of plasticized poly(L-lactic acid), *J. Appl. Polym. Sci.* 90 (2003) 1731–1738.
- [59] K. Sungsanit, N. Kao, S.N. Bhattacharya, Properties of linear poly(lactic acid)/polyethylene glycol blends, *Polym. Eng. Sci.* 52 (2012) 108–116.
- [60] A.U. Santhoskumar, A. Ramkumar, Preparation/characterization of plasticized poly(lactic acid) for packaging applications, *Turk. J. Sci. Techn.* 9 (2014) 73–79.
- [61] L.V. Labrecque, R.A. Kumar, V. Davé, R.A. Gross, S.P. McCarthy, Citrate esters as plasticizers for poly(lactic acid), *J. Appl. Polym. Sci.* 66 (1997) 1507–1513.
- [62] M.A. Shirai, C.M.O. Müller, M.V.E. Grossmann, F. Yamashita, Adipate and citrate esters as plasticizers for poly(lactic acid)/thermoplastic starch sheets, *J. Polym. Environ.* 23 (2015) 54–61.
- [63] M.P. Arrieta, E. Fortunati, F. Dominici, J. López, J.M. Kenny, Bionanocomposite films based on plasticized PLA-PHB/cellulose nanocrystal blends, *Carbohydr. Polym.* 121 (2015) 265–275.
- [64] C. Courgneau, Domenek Sandra, R. Lebossé, A. Guinault, L. Avérous, V. Ducruet, Effect of crystallization on barrier properties of formulated polylactide, *Polym. Int.* 61 (2012) 180–189.
- [65] M.P. Arrieta, J. López, D. López, J.M. Kenny, L. Peponi, Development of flexible materials based on plasticized electrospun PLA-PHA blends: structural, thermal, mechanical and disintegration properties, *Eur. Polym. J.* 73 (2015) 433–446.
- [66] J. Yu, N. Wang, X. Ma, Fabrication and characterization of poly(lactic acid)/acetyl tributyl citrate/carbon black as conductive polymer composites, *Biomacromolecules* 9 (2008) 1050–1057.
- [67] N. Wang, X. Zhang, X. Ma, J. Fang, Influence of carbon black on the properties of plasticized poly(lactic acid) composites, *Polym. Degrad. Stabil.* 93 (2008) 1044–1052.
- [68] E. Quero, A.J. Müller, F. Signori, M.-B. Coltelli, S. Bronco, Isothermal cold-crystallization of PLA/PBAT blends with and without the addition of acetyl tributyl citrate, *Macromol. Chem. Phys.* 213 (2012) 36–48.
- [69] A. Högglund, M. Hakkarainen, A.-C. Albertsson, Migration and hydrolysis of hydrophobic Polylactide plasticizer, *Biomacromolecules* 11 (2009) 277–283.
- [70] M.P. Arrieta, M.d.M. Castro-López, E. Rayón, L.F. Barral-Losada, J.M. López-Vilarino, J. López, M.V. González-Rodríguez, Plasticized poly(lactic acid)-poly (hydroxybutyrate) (PLA-PHB) blends incorporated with catechin intended for active food-packaging applications, *J. Agric. Food Chem.* 62 (2014) 10170–10180.
- [71] M.-B. Coltelli, I.D. Maggiore, M. Bertoldo, F. Signori, S. Bronco, F. Ciardelli, Poly (lactic acid) properties as a consequence of Poly(butylene adipate-co-terephthalate) blending and acetyl tributyl citrate plasticization, *J. Appl. Polym. Sci.* 110 (2008) 1250–1262.
- [72] N. Ljungberg, B. Wesslén, The effects of plasticizers on the dynamic mechanical and thermal properties of Poly(lactic acid), *J. Appl. Polym. Sci.* 86 (2002) 1227–1234.
- [73] R. Wang, C. Wan, S. Wang, Y. Zhang, Morphology, mechanical properties, and durability of poly(lactic acid) plasticized with Di(isononyl) cyclohexane-1,2-dicarboxylate, *Polym. Eng. Sci.* 49 (2009) 2414–2420.
- [74] N. Ljungberg, T. Andersson, B. Wesslén, Film extrusion and film weldability of Poly(lactic acid) plasticized with triacetate and tributyl citrate, *J. Appl. Polym. Sci.* 88 (2003) 3239–3247.
- [75] N. Ljungberg, B. Wesslén, Tributyl citrate oligomers as plasticizers for poly (lactic acid): thermo-mechanical film properties and aging, *Polym* 44 (2003) 7679–7688.
- [76] Y. Lemmouchi, M. Murariu, A.M.D. Santos, A.J. Amass, E. Schacht, P. Dubois, Plasticization of poly(lactide) with blends of tributyl citrate and low molecular weight poly(d,l-lactide)-b-poly(ethylene glycol) copolymers, *Eur. Polym. J.* 45 (2009) 2839–2848.
- [77] N. Ljungberg, B. Wesslén, Preparation and properties of plasticized Poly(lactic acid) films, *Biomacromolecules* 6 (2005) 1789–1796.
- [78] N. Burgos, D. Tolaguera, S. Fiori, A. Jiménez, Synthesis and characterization of lactic acid oligomers evaluation of performance as Poly(lactic acid) plasticizers, *J. Polym. Environ.* 22 (2014) 227–235.
- [79] I. Armentano, E. Fortunati, N. Burgos, F. Dominici, F. Luzi, S. Fiori, A. Jiménez, K. Yoon, J. Ahn, S. Kang, J.M. Kenny, Bio-based PLA-PHB plasticized blend films: processing and structural characterization, *Food Sci. Technol.* 64 (2015) 980–988.
- [80] N. Burgos, V.P. Martino, A. Jiménez, Characterization and ageing study of poly (lactic acid) films plasticized with oligomeric lactic acid, *Polym. Degrad. Stabil.* 98 (2013) 651–658.
- [81] R. Avolio, R. Castaldo, G. Gentile, V. Ambrogi, S. Fiori, M. Avella, M. Cocca, M. E. Errico, Plasticization of poly(lactic acid) through blending with oligomers of lactic acid effect of the physical aging on properties, *Eur. Polym. J.* 66 (2015) 533–542.
- [82] I. Armentano, E. Fortunati, N. Burgos, F. Dominici, F. Luzi, S. Fiori, A. Jiménez, K. Yoon, J. Ahn, S. Kang, J.M. Kenny, Processing and characterization of plasticized PLA-PHB blends for biodegradable multiphase systems, *Express Polym. Lett.* 9 (2015) 583–596.
- [83] N. Herrera, A.P. Mathew, K. Oksman, Plasticized polylactic acid/cellulose nanocomposites prepared using melt-extrusion and liquid feeding: mechanical, thermal and optical properties, *Compos. Sci. Technol.* 106 (2015) 149–155.
- [84] M. Murariu, A. Da Silva Ferreira, M. Pluta, L. Bonnaud, M. Alexandre, P. Dubois, Polylactide (PLA)-CaSO₄ composites toughened with low molecular weight and polymeric ester-like plasticizers and related performances, *Eur. Polym. J.* 44 (2008) 3842–3852.
- [85] V.P. Martino, R.A. Ruseckaite, A. Jiménez, Thermal and mechanical characterization of plasticized poly (L-lactide-co-D,L-lactide) films for food packaging, *J. Therm. Anal. Calorim.* 86 (2006) 707–712.
- [86] V.P. Martino, R.A. Ruseckaite, A. Jiménez, Ageing of poly(lactic acid) films plasticized with commercial polyadipates, *Polym. Int.* 58 (2009) 437–444.
- [87] V.P. Martino, A. Jiménez, R.A. Ruseckaite, Processing and characterization of poly(lactic acid) films plasticized with commercial adipates, *J. Appl. Polym. Sci.* 112 (2009) 2010–2018.
- [88] M.P. Arrieta, J. López, A. Hernández, E. Rayón, Ternary PLA-PHB-Limonene blends intended for biodegradable food packaging applications, *Eur. Polym. J.* 50 (2014) 255–270.
- [89] M.P. Arrieta, J. López, S. Ferrándiz, M.A. Peltzer, Characterization of PLA-limonene blends for food packaging applications, *Polym. Test.* 32 (2013) 760–768.
- [90] E. Fortunati, F. Luzi, D. Puglia, F. Dominici, C. Santulli, J.M. Kenny, L. Torre, Investigation of thermo-mechanical, chemical and degradative properties of PLA-limonene films reinforced with cellulose nanocrystals extracted from Phormium tenax leaves, *Eur. Polym. J.* 56 (2014) 77–91.
- [91] M. Ramos, A. Jiménez, M. Peltzer, M.C. Garrigós, Development of novel nano-biocomposite antioxidant films based on poly (lactic acid) and thymol for active packaging, *Food Chem.* 162 (2014) 149–155.
- [92] I.S.M.A. Tawakkal, M.J. Cran, S.W. Bigger, Effect of kenaf fibre loading and thymol concentration on the mechanical and thermal properties of PLA/kenaf/thymol composites, *Ind. Crop. Prod.* 61 (2014) 74–83.
- [93] M. Ramos, E. Fortunati, M. Peltzer, F. Dominici, A. Jiménez, M.d.C. Garrigós, J. M. Kenny, Influence of thymol and silver nanoparticles on the degradation of poly (lactic acid) based nanocomposites: thermal and morphological properties, *Polym. Degrad. Stabil.* 108 (2014) 158–165.
- [94] N. Ljungberg, B. Wesslén, Thermomechanical film properties and aging of blends of poly(lactic acid) and malonate oligomers, *J. Appl. Polym. Sci.* 94 (2004) 2140–2149.
- [95] J. Alam, M. Alam, M. Raja, Z. Abduljaleel, L.A. Dass, MWCNTs-reinforced epoxidized linseed oil plasticized Polylactic acid nanocomposite and its electroactive shape memory behaviour, *Int. J. Mol. Sci.* 15 (2014) 19924–19937.
- [96] J.F. Balart, V. Fombuena, O. Fenollar, T. Boronat, L. Sánchez-Nacher, Processing and characterization of high environmental efficiency composites based on PLA and hazelnut shell flour (HSF) with biobased plasticizers derived from epoxidized linseed oil (ELO), *Compos. B Eng.* 86 (2016) 168–177.
- [97] K. Okamoto, T. Ichikawa, T. Yokohara, M. Yamaguchi, Miscibility, mechanical and thermal properties of poly(lactic acid)/polyester-diol blends, *Eur. Polym. J.* 45 (2009) 2304–2312.
- [98] Y. Yang, Z. Xiong, L. Zhang, Z. Tang, R. Zhang, J. Zhu, Isosorbide diacetate as a “green” plasticizer for poly(lactic acid), *Mater. Des.* 91 (2016) 262–268.

- [99] B.W. Chieng, N.A. Ibrahim, Y.Y. Then, Epoxidized vegetable oils plasticized Poly (lactic acid) biocomposites mechanical thermal and morphology properties, *Molecules* 19 (2014) 16024–16038.
- [100] F. Ali, Y.-W. Chang, S.C. Kang, J.Y. Yoon, Thermal mechanical and rheological properties of poly (lactic acid)/epoxidized soybean oil blends, *Polym. Bull.* 62 (2009) 91–98.
- [101] M.A. Abdelwahab, A. Flynn, B.-S. Chiou, S. Imam, W. Orts, E. Chiellini, Thermal, mechanical and morphological characterization of plasticized PLA-PHB blends, *Polym. Degrad. Stabil.* 97 (2012) 1822–1828.
- [102] Y. Wang, Y. Qin, Y. Zhang, M. Yuan, H. Li, M. Yuan, Effects of N-octyl lactate as plasticizer on the thermal and functional properties of extruded PLA-based films, *Int. J. Biol. Macromol.* 67 (2014) 58–63.
- [103] N. Ljungberg, D. Colombini, B. Wesslén, Plasticization of poly(lactic acid) with oligomeric malonate esteramides: dynamic mechanical and thermal film properties, *J. Appl. Polym. Sci.* 96 (2005) 992–1002.
- [104] E.F. Santos, R.V.B. Oliveira, Q.B. Reiznaut, D. Samios, S.M.B. Nachtigall, Sunflower-oil biodiesel-oligoesters/poly(lactide) blends: plasticizing effect and ageing, *Polym. Test.* 39 (2014) 23–29.
- [105] H. Xiao, W. Lu, J.-T. Yeh, Effect of plasticizer on the crystallization behavior of poly(lactic acid), *J. Appl. Polym. Sci.* 113 (2009) 112–121.
- [106] A. López-Rubio, J.M. Lagaron, Improvement of UV stability and mechanical properties of biopolyesters through the addition of β -carotene, *Polym. Degrad. Stabil.* 95 (2010) 2162–2168.
- [107] F. Hassouna, J.-M. Raquez, F. Addiego, V. Toniazio, P. Dubois, D. Ruch, New development on plasticized poly(lactide): chemical grafting of citrate on PLA by reactive extrusion, *Eur. Polym. J.* 48 (2012) 404–415.
- [108] K.-m. Choi, M.-C. Choi, D.-H. Han, T.-S. Park, C.-S. Ha, Plasticization of poly (lactic acid) (PLA) through chemical grafting of poly(ethylene glycol) (PEG) via in situ reactive blending, *Eur. Polym. J.* 49 (2013) 2356–2364.
- [109] Z. Ren, L. Dong, Y. Yang, Dynamic mechanical and thermal properties of plasticized poly(lactic acid), *J. Appl. Polym. Sci.* 101 (2006) 1583–1590.
- [110] Z. Gui, Y. Xu, Y. Gao, C. Lu, S. Cheng, Novel polyethylene glycol-based polyester-toughened polylactide, *Mater. Lett.* 71 (2012) 63–65.
- [111] K. Bechtold, M.A. Hillmyer, W.B. Tolman, Perfectly alternating copolymer of lactic acid and ethylene oxide as a plasticizing agent for polylactide, *Macromolecules* 34 (2001) 8641–8648.
- [112] H. Huang, L. Chen, G. Song, G. Tang, An efficient plasticization method for poly (lactic acid) using combination of liquid-state and solid-state plasticizers, *J. Appl. Polym. Sci.* 135 (2018) 46669.
- [113] D. Li, Y. Jiang, S. Lv, X. Liu, J. Gu, Q. Chen, Y. Zhang, Preparation of plasticized poly (lactic acid) and its influence on the properties of composite materials, *PLoS One* 13 (2018), e0193520.
- [114] B. Wang, K. Hina, H. Zou, D. Zou, C. Yi, Thermal, crystallization, mechanical and decomposition properties of poly(lactic acid) plasticized with poly(ethylene glycol), *J. Vinyl Addit. Technol.* 24 (2018) E154–E163.
- [115] Z. Lule, H. Ju, J. Kim, Thermomechanical properties of alumina-filled plasticized polylactide acid: effect of alumina loading percentage, *Ceram. Int.* 44 (2018) 22767–22776.
- [116] A. Chaos, A. Sangroniz, J. Fernández, J.D. Río, M. Iriarte, J.R. Sarasua, A. Etxeberria, Plasticization of poly(lactide) with poly(ethylene glycol). Low weight plasticizer vs triblock copolymers, *J. Appl. Polym. Sci.* 137 (2020) 48868.
- [117] B. Darabian, H. Bagheri, S. Mohammadi, Improvement in mechanical properties and biodegradability of PLA using poly(ethylene glycol) and triacetin for antibacterial wound dressing applications, *Prog. Biomater.* 9 (2020) 45–64.
- [118] L. Aliotta, P. Cinelli, M.B. Coltelli, A. Lazzeri, Rigid filler toughening in PLA-Calcium Carbonate composites: effect of particle surface treatment and matrix plasticization, *Eur. Polym. J.* 113 (2019) 78–88.
- [119] A.A. Singh, S. Sharma, M. Srivastava, A. Majumdar, Modulating the properties of polylactide acid for packaging applications using biobased plasticizers and naturally obtained fillers, *Int. J. Biol. Macromol.* 153 (2020) 1165–1175.
- [120] C.-H. Tsou, C. Gao, M. De Guzman, D.-Y. Wu, W.-S. Hung, L. Yuan, M.-C. Suen, J.-t. Yeh, Preparation and characterization of poly(lactic acid) with adipate ester added as a plasticizer, *Polym. Polym. Compos.* 26 (2018).
- [121] A. Orue, A. Eceiza, A. Arbelaz, Preparation and characterization of poly(lactic acid) plasticized with vegetable oils and reinforced with sisal fibers, *Ind. Crop. Prod.* 112 (2018) 170–180.
- [122] S.M. Bhasney, R. Patwa, A. Kumar, V. Katiyar, Plasticizing effect of coconut oil on morphological, mechanical, thermal, rheological, barrier, and optical properties of poly(lactic acid), *J. Appl. Polym. Sci.* 5 (2017) 45390.
- [123] M.C. Righetti, P. Cinelli, N. Mallegni, C.A. Massa, M. Irakli, A. Lazzeri, Effect of the addition of natural rice bran oil on the thermal, mechanical, morphological and viscoelastic properties of Poly(Lactic Acid), *Sustainability* 11 (2019) 2783.
- [124] G. Mele, E. Bloise, F. Cosentino, D. Lomonaco, F. Avelino, T. Marciàno, C. Massaro, S.E. Mazzetto, L. Tammaro, A.G. Scalone, M. Schioppa, R. Terzi, Influence of cardanol oil on the properties of poly(lactic acid) films produced by melt extrusion, *ACS Omega* 4 (2019) 718–726.
- [125] B.W. Chieng, N.A. Ibrahim, Y.Y. Then, Y.Y. Loo, Epoxidized jatropa oil as a sustainable plasticizer to poly(lactic acid), *Polym* 9 (2017) 204.
- [126] J. Kantee, S. Kajorncheappunngam, Properties of plasticized polylactide acid films with epoxidized rubber seed oil, *Chiang Mai J. Sci.* 44 (2017) 1591–1600.
- [127] R. Turco, R. Ortega-Toro, R. Tesser, S. Mallardo, S. Collazo-Bigliardi, A.C. Boix, M. Malinconico, M. Ripa, M.D. Serio, G. Santagata, Poly (Lactic Acid)/thermoplastic starch films: effect of cardoon seed epoxidized oil on their chemophysical, mechanical, and barrier properties, *Coatings* 9 (2019) 574.
- [128] A. Carbonell-Verdu, D. Garcia-Garcia, F. Dominici, L. Torre, L. Sanchez-Nacher, R. Balart, PLA films with improved flexibility properties by using maleinized cottonseed oil, *Eur. Polym. J.* 91 (2017) 248–259.
- [129] J.M. Ferri, D. Garcia-Garcia, N. Montanes, O. Fenollar, R. Balart, The effect of maleinized linseed oil as biobased plasticizer in poly(lactic acid)-based formulations, *Polym. Int.* 66 (2017) 882–891.
- [130] L. Quiles-Carrillo, M.M. Blanes-Martínez, N. Montanes, O. Fenollar, S. Torres-Giner, R. Balart, Reactive toughening of injection-molded polylactide pieces using maleinized hemp seed oil, *Eur. Polym. J.* 98 (2018) 402–410.
- [131] D. Garcia-Garcia, A. Carbonell-Verdu, M.P. Arrieta, J. Lopez-Martinez, Improvement of PLA film ductility by plasticization with epoxidizedkaranja oil, *Polym. Degrad. Stabil.* 179 (2020).
- [132] F. Cicogna, S. Coiai, C.D. Monte, R. Spiniello, S. Fiori, M. Franceschi, F. Braca, P. Cinelli, S.M.K. Fehri, A. Lazzeri, W. Oberhauser, E. Passaglia, Poly(lactic acid) plasticized with low-molecular-weight polyesters: structural, thermal and biodegradability features, *Polym. Int.* 66 (2017) 761–769.
- [133] S. Rojas-Lema, L. Quiles-Carrillo, D. Garcia-Garcia, B. Melendez-Rodriguez, R. Balart, S. Torres-Giner, Tailoring the properties of thermo-compressed polylactide films for food packaging applications by individual and combined additions of Lactic Acid oligomer and halloysite nanotubes, *Molecules* 25 (2020), 1976.
- [134] S. Solarski, M. Ferreira, E. Devaux, Ageing of polylactide and polylactide nanocomposite filaments, *Polym. Degrad. Stabil.* 93 (2008) 707–713.
- [135] A. Celli, M. Scandola, Thermal properties and physical ageing of poly (l-lactic acid), *Polym* 33 (1992) 2699–2703.
- [136] Y. Li, H. Shimizu, Toughening of polylactide by melt blending with a biodegradable poly(ether)urethane elastomer, *Macromol. Biosci.* 7 (2007) 921–928.
- [137] N.F. Alias, H. Ismail, An overview of toughening polylactic acid by an elastomer, *PPTEC* 58 (2019) 1399–1422.
- [138] N. Bitinis, R. Verdejo, P. Cassagnau, M.A. Lopez-Manchado, Structure and properties of polylactide/natural rubber blends, *Mater. Chem. Phys.* 129 (2011) 823–831.
- [139] K. Pongtanayut, C. Thongpin, O. Santawitee, The effect of rubber on morphology, thermal properties and mechanical properties of PLA/NR and PLA/ENR blends, *Energy Procedia* 34 (2013) 888–897.
- [140] C. Xu, D. Yuan, L. Fu, Y. Chen, Physical blend of PLA/NR with co-continuous phase structure: preparation, rheology property, mechanical properties and morphology, *Polym. Test.* 37 (2014) 94–101.
- [141] D. Yuan, C. Xu, Z. Chen, Y. Chen, Crosslinked bicontinuous biobased polylactide/natural rubber materials: super toughness, “net-like”-structure of NR phase and excellent interfacial adhesion, *Polym. Test.* 38 (2014) 73–80.
- [142] D. Yuan, K. Chen, C. Xu, Z. Chen, Y. Chen, Crosslinked bicontinuous biobased PLA/NR blends via dynamic vulcanization using different curing systems, *Carbohydr. Polym.* 113 (2014) 438–445.
- [143] R. Jaratrotkamjorn, C. Khaokong, V. Tanrattanakul, Toughness enhancement of poly(lactide) by melt blending with natural rubber, *J. Appl. Polym. Sci.* 124 (2012) 5027–5036.
- [144] Y. Chen, D. Yuan, C. Xu, Dynamically vulcanized biobased polylactide/natural rubber blend material with continuous cross-linked rubber phase, *ACS Appl. Mater. Interfaces* 6 (2014) 3811–3816.
- [145] M. Nematollahi, A. Jalali-Arani, H. Modarress, High-performance bio-based poly (lactic acid)/natural rubber/epoxidized natural rubber blends: effect of epoxidized natural rubber on microstructure, toughness and static and dynamic mechanical properties, *Polym. Int.* 68 (2018) 439–446.
- [146] J. Klinkajorn, V. Tanrattanakul, Compatibilization of poly(lactic acid)/epoxidized natural rubber blend with maleic anhydride, *J. Appl. Polym. Sci.* 137 (2019) 48297.
- [147] S. Sathornluck, C. Choochotiro, Modification of epoxidized natural rubber as a PLA toughening agent, *J. Appl. Polym. Sci.* 136 (2019) 48267.
- [148] W. Tissanan, R. Chanthayanonth, M. Yamaguchi, P. Phinyocheep, Improvement of mechanical and impact performance of poly(lactic acid) by renewable modified natural rubber, *J. Clean. Prod.* 276 (2020) 123800.
- [149] W. Phomma, R. Magaraphan, Fabrication of admicelled natural rubber by polycaprolactone for toughening poly(lactic acid), *J. Polym. Environ.* 26 (2018) 2268–2280.
- [150] H.-C. Zhang, J. Huang, P.-F. Zhao, X. Lu, Bio-based ethylene-co-vinyl acetate/poly (lactic acid) thermoplastic vulcanizates with enhanced mechanical strength and shape memory behavior, *Polym. Test.* 87 (2020) 106537.
- [151] P. Ma, D.G. Hristova-Bogaerds, J.G.P. Goossens, A.B. Spoelstra, Y. Zhang, P. J. Lemstra, Toughening of poly(lactic acid) by ethylene-co-vinyl acetate copolymer with different vinyl acetate contents, *Eur. Polym. J.* 48 (2012) 146–154.
- [152] P. Xu, P. Ma, M. Hoch, E. Arnoldi, X. Cai, W. Dong, M. Chen, Transparent blown films from poly(lactide) and poly(ethylene-co-vinyl acetate) compounds: structure and property, *Polym. Degrad. Stabil.* 129 (2016) 328–337.
- [153] D. Kugimoto, S. Kouda, M. Yamaguchi, Improvement of mechanical toughness of poly(lactic acid) by addition of ethylene-vinyl acetate copolymer, *Polym. Test.* 80 (2019) 106021.
- [154] J.-S. Yoon, S.-H. Oh, M.-N. Kim, I.-J. Chin, Y.-H. Kim, Thermal and mechanical properties of poly(l-lactic acid)-poly (ethylene-co-vinyl acetate) blends, *Polym* 40 (1999) 2303–2312.
- [155] D. Van Cong, T. Hoang, N.V. Giang, N.T. Ha, T.D. Lam, M. Sumita, A novel enzymatic biodegradable route for PLA/EVA blends under agricultural soil of Vietnam, *Mater. Sci. Eng. C* 32 (2012) 558–563.

- [156] M.R. Aghjeh, M. Nazari, H.A. Khonakdar, S.H. Jafari, U. Wagenknecht, G. Heinrich, In depth analysis of micro-mechanism of mechanical property alternations in PLA/EVA/clay nanocomposites: a combined theoretical and experimental approach, *Mater. Des.* 88 (2015) 1277–1289.
- [157] N. Zhang, X. Lu, Morphology and properties of super-toughened bio-based poly(lactic acid)/Poly(ethylene-co-vinyl acetate) blends by peroxide-induced dynamic vulcanization and interfacial compatibilization, *Polym. Test.* 56 (2016) 354–363.
- [158] P. Ma, P. Xu, Y. Zhai, W. Dong, Y. Zhang, M. Chen, Biobased poly(lactide)/ethylene-co-vinyl acetate thermoplastic vulcanizates: morphology evolution, superior properties, and partial degradability, *ACS Sustain. Chem. Eng.* 3 (2015) 2211–2219.
- [159] I. Moura, R. Nogueira, V. Bounor-Legare, A.V. Machado, Synthesis of EVA-g-PLA copolymers using transesterification reactions, *Mater. Chem. Phys.* 134 (2012) 103–110.
- [160] T. Tábi, The application of the synergistic effect between the crystal structure of Poly(Lactic Acid) (PLA) and the presence of Ethylene Vinyl Acetate copolymer (EVA) to produce highly ductile PLA/EVA blends, *J. Therm. Anal. Calorim.* 138 (2019) 1287–1297.
- [161] M. Pracella, M.M.-U. Haque, M. Paci, V. Alvarez, Property tuning of poly(lactic acid)/cellulose bio-composites through blending with modified ethylene-vinyl acetate copolymer, *Carbohydr. Polym.* 137 (2016) 515–524.
- [162] M.R. Aghjeh, V. Asadi, P. Mehdijabbar, H.A. Khonakdar, S.H. Jafari, Application of linear rheology in determination of nanoclay localization in PLA/EVA/Clay nanocomposites: correlation with microstructure and thermal properties, *Comp. B Eng.* 86 (2016) 273–284.
- [163] H.T. Oyama, Super-tough poly(lactic acid) materials: reactive blending with ethylene copolymer, *Polym* 50 (2009) 747–751.
- [164] D. Notta-Cuvier, A. Bouzouita, R. Delille, G. Haugou, J.-M. Raquez, F. Lauro, P. Dubois, Design of toughened PLA based material for application in structures subjected to severe loading conditions. Part 1. Quasi-static and dynamic tensile tests at ambient temperature, *Polym. Test.* 54 (2016) 233–243.
- [165] A. Bouzouita, D. Notta-Cuvier, R. Delille, F. Lauro, J.-M. Raquez, P. Dubois, Design of toughened PLA based material for application in structures subjected to severe loading conditions. Part 2. Quasi-static tensile tests and dynamic mechanical analysis at ambient and moderately high temperature, *Polym. Test.* 57 (2017) 235–244.
- [166] K.A. Afrifah, L.M. Matuana, Impact modification of polylactide with a biodegradable ethylene/acrylate copolymer, *Macromol. Mater. Eng.* 295 (2010) 802–811.
- [167] N. Niaounakis, *Biopolymers: Processing and Products*, Elsevier Inc., USA, 2015.
- [168] B. Imre, B. Pukánszky, Compatibilization in bio-based and biodegradable polymer blends, *Eur. Polym. J.* 49 (2013) 1215–1233.
- [169] T. Fujimaki, Processability and properties of aliphatic polyesters, 'BIONOLLE', synthesized by polycondensation reaction, *Polym. Degrad. Stabil.* 59 (1998) 209–214.
- [170] <http://helianpolymers.com/mitsubishi-chemical-biopolymers/>.
- [171] I. Burzic, C. Pretschuh, D. Kaineder, G. Eder, J. Smilek, J. Másilko, W. Kateryna, Impact modification of PLA using biobased biodegradable PHA biopolymers, *Eur. Polym. J.* 114 (2019) 32–38.
- [172] J.V. Ecker, I. Burzic, A. Haider, S. Hild, H. Rennerhofer, Improving the impact strength of PLA and its blends with PHA in fused layer modelling, *Polym. Test.* 78 (2019) 105929.
- [173] R. Plavec, S. Hlaváčiková, L. Omanfková, J. Feranc, Z. Vanovčanová, K. Tomanová, J. Bočák, J. Kruželák, E. Medlenová, I. Gálišová, L. Danišová, R. Příkryl, S. Figalla, V. Melčová, P. Alexy, Recycling possibilities of bioplastics based on PLA/PHB blends, *Polym. Test.* 92 (2020) 106880.
- [174] J.W. Park, S.S. Im, Phase behavior and morphology in blends of poly(L-lactic acid) and poly(butylene succinate), *J. Appl. Polym. Sci.* 86 (2002) 647–655.
- [175] T. Yokohara, M. Yamaguchi, Structure and properties for biomass-based polyester blends of PLA and PBS, *Eur. Polym. J.* 44 (2008) 677–685.
- [176] L. Jompang, S. Thumsorn, J.W. On, P. Surin, C. Apawet, T. Chaichalermwong, N. Kaabuahtong, N. O-Charoen, N. Srisawat, Poly(Lactic Acid) and poly(butylene succinate) blend fibers prepared by melt spinning technique, *Energy Procedia* 34 (2013) 493–499.
- [177] X. Liu, M. Dever, N. Fair, R.S. Benson, Thermal and mechanical properties of poly(lactic acid) and poly(ethylene/butylene succinate) blends, *J. Environ. Polym. Degrad.* 5 (1997) 225–235.
- [178] D. Wu, L. Yuan, E. Laredo, M. Zhang, W. Zhou, Interfacial properties, viscoelasticity, and thermal behaviors of poly(butylene succinate)/polylactide blend, *Ind. Eng. Chem. Res.* 51 (2012) 2290–2298.
- [179] A. Bhatia, R.K. Gupta, S.N. Bhattacharya, H.J. Choi, Compatibility of biodegradable Poly(lactide acid) (PLA) and Poly(butylene succinate) (PBS) blends for packaging application, *Korea Aust. Rheol. J.* 19 (2007) 125–131.
- [180] Y. Deng, N.L. Thomas, Blending poly(butylene succinate) with poly(lactic acid): ductility and phase inversion effects, *Eur. Polym. J.* 71 (2015) 534–546.
- [181] R.-Y. Chen, W. Zou, C.-R. Wu, S.-K. Jia, Z. Huang, G.-Z. Zhang, J.-P. Qu, Poly(lactic acid)/Poly(butylene succinate)/calcium sulfate whiskers biodegradable blend prepared by vane extruder: analysis of mechanical properties, morphology, and crystallization behavior, *Polym. Test.* 34 (2014) 1–9.
- [182] V. Ojijo, S.S. Ray, R. Sadiku, Toughening of biodegradable polylactide/poly(butylene succinate-co-adipate) blends via in situ reactive compatibilization, *ACS Appl. Mater. Interfaces* 5 (2013) 4266–4276.
- [183] M. Harada, T. Ohya, K. Iida, H. Hayashi, K. Hirano, H. Fukuda, Increased impact strength of biodegradable poly(lactic acid)/poly(butylene succinate) blend composites by using isocyanate as a reactive processing agent, *J. Appl. Polym. Sci.* 106 (2007) 1813–1820.
- [184] V. Vilay, M. Mariatti, Z. Ahmad, K. Pasomsouk, M. Todo, Characterization of the mechanical and thermal properties and morphological behavior of biodegradable poly(L-lactide)/poly(ϵ -caprolactone) and poly(L-lactide)/poly(butylene succinate-co-L-lactate) polymeric blends, *J. Appl. Polym. Sci.* 114 (2009) 1784–1792.
- [185] M. Shibata, Y. Inoue, M. Miyoshi, Mechanical properties, morphology, and crystallization behavior of blends of poly(L-lactide) with poly(butylene succinate-co-lactate) and poly(butylene succinate), *Polym* 47 (2006) 3557–3564.
- [186] Y. Wang, J.F. Mano, Biodegradable poly(L-lactic acid)/poly(butylene succinate-co-adipate) blends: miscibility, morphology, and thermal behavior, *J. Appl. Polym. Sci.* 105 (2007) 3204–3210.
- [187] M.E. Broz, D.L. VanderHart, N.R. Washburn, Structure and mechanical properties of poly(D,L-lactic acid)/poly(ϵ -caprolactone) blends, *Biomaterials* 24 (2003) 4181–4190.
- [188] V.B. Carmona, A.C. Correa, J.M. Marconcini, L.H.C. Mattoso, Properties of a biodegradable ternary blend of thermoplastic starch (TPS), Poly(ϵ -caprolactone) (PCL) and Poly(lactic acid) (PLA), *J. Polym. Environ.* 23 (2015) 83–89.
- [189] B.Y. Shin, D.H. Han, Compatibilization of immiscible poly(lactic acid)/poly(ϵ -caprolactone) blend through electron-beam irradiation with the addition of a compatibilizing agent, *Radiat. Phys. Chem.* 83 (2013) 98–104.
- [190] T. Takayama, M. Todo, H. Tsu, Effect of annealing on the mechanical properties of PLA/PCL and PLA/PCL/LTI polymer blends, *J. Mech. Behav. Biomed. Mat.* 4 (2011) 255–260.
- [191] F. Tuba, Fracture Toughness-Microstructure Relationships in Biodegradable Medical Polymers, Budapest University of Technology and Economics, 2012. PhD Thesis.
- [192] K. Chavalitpanya, S. Phattananudee, Poly(lactic acid)/polycaprolactone blends compatibilized with block copolymer, *Energy Procedia* 34 (2013) 542–548.
- [193] H. Bai, C. Huang, H. Xiu, Y. Gao, Q. Zhang, Q. Fu, Toughening of poly(L-lactide) with poly(ϵ -caprolactone): combined effects of matrix crystallization and impact modifier particle size, *Polym* 54 (2013) 5257–5266.
- [194] H. Bai, H. Xiu, J. Gao, H. Deng, Q. Zhang, M. Yang, Q. Fu, Tailoring impact toughness of poly(L-lactide)/poly(ϵ -caprolactone) (PLLA/PCL) blends by controlling crystallization of PLLA matrix, *Appl. Mater. Interfaces* 4 (2012) 897–905.
- [195] A. Amor, N. Okhay, A. Guinault, G. Miquelard-Garnier, C. Sollogoub, M. Gervais, Combined compatibilization and plasticization effect of low molecular weight poly(lactic acid) in poly(lactic acid)/poly(3-hydroxybutyrate-co-3-hydroxyvalerate) blends, *Express Polym. Lett.* 12 (2018) 114–125.
- [196] L. Jiang, M.P. Wolcott, J. Zhang, Study of biodegradable poly(lactide)/poly(butylene adipate-co-terephthalate) blends, *Biomacromolecules* 7 (2006) 199–207.
- [197] N. Zhang, Q. Wang, J. Ren, L. Wang, Preparation and properties of biodegradable poly(lactic acid)/poly(butylene adipate-co-terephthalate) blend with glycidyl methacrylate as reactive processing agent, *J. Mater. Sci.* 44 (2009) 250–256.
- [198] R. Wang, S. Wang, Y. Zhang, C. Wan, P. Ma, Toughening modification of PLLA/PBS blends via in situ compatibilization, *Polym. Eng. Sci.* 49 (2009) 26–33.
- [199] X. Hu, T. Su, P. Li, Z. Wang, Blending modification of PBS/PLA and its enzymatic degradation, *Polym. Bull.* 75 (2018) 533–546.
- [200] M. Harada, K. Iida, K. Okamoto, H. Hayashi, K. Hirano, Reactive compatibilization of biodegradable poly(lactic acid)/poly(ϵ -caprolactone) blends with reactive processing agents, *Polym. Eng. Sci.* 15 (2008) 1359–1368.
- [201] J. Odent, J.-M. Raquez, P. Leclère, F. Lauro, P. Dubois, Crystallization-induced toughness of rubber-modified polylactide: combined effects of biodegradable impact modifier and effective nucleating agent, *Polym. Adv. Technol.* 26 (2015) 814–822.
- [202] X. Xiao, V.S. Chevali, P. Song, B. Yu, Y. Yang, H. Wang, Enhanced toughness of PLLA/PCL blends using poly(D-lactide)-poly(ϵ -caprolactone)-poly(D-lactide) as compatibilizer, *Compos. Commun.* 21 (2020) 100385.
- [203] X. Wang, S. Peng, H. Chen, X. Yu, X. Zhao, Mechanical properties, rheological behaviors, and phase morphologies of high-toughness PLA/PBAT blends by in-situ reactive compatibilization, *Compos. B Eng.* 173 (2019) 107028.
- [204] Y. Ding, W. Feng, D. Huang, B. Lu, P. Wang, G. Wang, J. Ji, Compatibilization of immiscible PLA-based biodegradable polymer blends using amphiphilic di-block copolymers, *Eur. Polym. J.* 118 (2019) 45–52.
- [205] A. Carbonell-Verdu, J.M. Ferri, F. Dominici, T. Boronat, L. Sanchez-Nacher, R. Balart, L. Torre, Manufacturing and compatibilization of PLA/PBAT binary blends by cottonseed oil-based derivatives, *Express Polym. Lett.* 12 (2018) 808–823.
- [206] X. Zhang, K. Schneider, G. Liu, J. Chen, K. Bruning, D. Wang, M. Stamm, Structure variation of tensile-deformed amorphous poly(L-lactic acid): Effects of deformation rate and strain, *Polymer* 52 (2011) 4141–4149.
- [207] K. Billimoria, E.L. Heeley, N. Parsons, L. Figiel, An investigation into the crystalline morphology transitions in poly-L-lactic acid (PLLA) under uniaxial deformation in the quasi-solid-state regime, *Eur. Polym. J.* 101 (2018) 127–139.
- [208] X. Chen, J. Kalish, S.L. Hsu, Structure evolution of α' -phase poly(lactic acid), *J. Polym. Sci. B Polym. Phys.* 49 (2011) 1446–1454.
- [209] D. Sawai, T. Yokoyama, T. Kanamoto, M. Sungil, S.-H. Hyon, L.P. Myasnikova, Crystal transformation and development of tensile properties upon drawing of poly(L-lactic acid) by solid-state coextrusion: effects of molecular weight, *Macromol. Symp.* 242 (2006) 93–103.
- [210] R. Xu, J. Xie, C. Lei, Influence of melt-draw ratio on the crystalline behaviour of a polylactic acid cast film with a chi structure, *RSC Adv.* 7 (2017) 39914–39921.
- [211] M.R.M. Zin, A. Mahendrasingam, C. Konkel, T. Narayanan, Effect of D-isomer content on strain-induced crystallization behaviour of Poly(lactic acid) polymer under high speed uniaxial drawing, *Polym* 216 (2016) 123422.

- [212] T. Zhang, P. Wu, Q. Yang, J. Jiang, Fabrication of reinforced and toughened poly (lactic acid)/poly(butylene adipate-co-terephthalate) composites through solid die drawing process, *J. Appl. Polym. Sci.* 137 (2020) 49071.
- [213] Kazuyo Takahashi, D. Sawai, T. Yokoyama, T. Kanamoto, S.-H. Hyon, Crystal transformation from the α - to the β -form upon tensile drawing of poly(L-lactic acid), *Polym* 45 (2004) 4969–4976.
- [214] Y. Chen, L. Zhao, H. Pan, S. Jia, L. Han, L. Dong, Impact of d-isomer content on the microstructure and mechanical properties of uniaxially pre-stretched poly (lactic acid), *Polym* 186 (2020) 122022.
- [215] K. Pölöskei, G. Csézi, S. Hajba, T. Tábi, Investigation of the thermoformability of various D-Lactide content poly(lactic acid) films by ball burst test *Polym. Eng. Sci.* 60 (2020) 1266–1277.
- [216] N. Rahman, T. Kawai, G. Matsuba, K. Nishida, T. Kanaya, H. Watanabe, H. Okamoto, M. Kato, A. Usuki, M. Matsuda, K. Nakajima, N. Honma, Effect of polylactide stereocomplex on the crystallization behavior of poly(L-lactic acid), *Macromolecules* 42 (2009) 4739–4745.
- [217] L. Bouapao, H. Tsuji, Stereocomplex crystallization and spherulite growth of low molecular weight Poly(L-lactide) and Poly(D-lactide) from melt, *Macromol. Chem. Phys.* 210 (2009) 993–1002.
- [218] S. Brochu, R.E. Prud'homme, I. Barakat, R. Jerome, Stereocomplexation and morphology of polylactides, *Macromolecules* 28 (1995) 5230–5239.
- [219] Y. He, Y. Xu, J. Wei, Z. Fan, S. Li, Unique crystallization behavior of poly(L-lactide)/poly(D-lactide) stereocomplex depending on initial melt states, *Polym* 49 (2008) 5670–5675.
- [220] H. Yamane, K. Sasai, Effect of the addition of poly(D-lactic acid) on the thermal property of poly(L-lactic acid), *Polym* 44 (2003) 2569–2575.
- [221] H. Xu, S. Tang, J. Chen, P. Yin, W. Pu, Y. Lu, Thermal and phase-separation behavior of injection-molded poly(L-lactic acid)/poly(D-lactic acid) blends with moderate optical purity, *Polym. Bull.* 68 (2012) 1135–1151.
- [222] J.R. Sarasua, A.L. Arraiza, P. Balerdi, I. Maiza, Crystallinity and mechanical properties of optically pure polylactides and their blends, *Polym. Eng. Sci.* 45 (2005) 745–753.
- [223] H. Tsuji, I. Fukui, Enhanced thermal stability of poly(lactide)s in the melt by enantiomeric polymer blending, *Polym* 44 (2003) 2891–2896.
- [224] Y. Phuphuak, Y. Miao, P. Zinck, S. Chirachanchai, Balancing crystalline and amorphous domains in PLA through star-structured polylactides with dual plasticizer/nucleating agent functionality, *Polym* 54 (2013) 7058–7070.
- [225] H. Tsuji, Autocatalytic hydrolysis of amorphous-made polylactides: effects of l-lactide content, tacticity, and enantiomeric polymer blending, *Polym* 43 (2002) 1789–1796.
- [226] H. Tsuji, Poly(lactic acid) stereocomplexes: a decade of progress, *Adv. Drug Deliv. Rev.* 107 (2016) 97–135.
- [227] F. Luo, A. Fortenberry, J. Ren, Z. Qiang, Recent progress in enhancing poly(lactic acid) stereocomplex formation for material property improvement, *Front. Chem.* 8 (2020) 688.
- [228] B.-G. Wu, W.-J. Yang, D.-Y. Niu, W.-F. Dong, M.-Q. Chen, T.-X. Liu, M.-L. Du, P.-M. Ma, Stereocomplexed poly(lactide) composites toward engineering plastics with superior toughness, heat resistance and anti-hydrolysis, *Chin. J. Polym. Sci.* 38 (2020) 1107–1116.
- [229] Y. Boonlaksiri, B. Prapagdee, N. Sombatsompop, Effect of poly(D-lactic acid) and cooling temperature on heat resistance and antibacterial performance of stereocomplex poly(L-lactic acid), *J. Appl. Polym. Sci.* 137 (2020) 48970.
- [230] H. Tsuji, In vitro hydrolysis of blends from enantiomeric poly(lactide)s Part 1. Well-stereo-complexed blend and non-blended films, *Polym* 41 (2000) 3621–3630.
- [231] M. Hortós, M. Viñas, S. Espino, J.J. Bou, Influence of temperature on high molecular weight poly(lactic acid) stereocomplex formation, *Express Polym. Lett.* 13 (2019) 123–134.
- [232] Y. Srithep, D. Pholharn, Lih-ShengTurng, O. Veang-in, Injection molding and characterization of polylactide stereocomplex, *Polym. Degrad. Stabil.* 120 (2015) 290–299.
- [233] X.R. Gao, B. Niu, W.Q. Hua, Y. Li, L. Xu, Y. Wang, X. Ji, G.J. Zhong, Z.M. Li, Rapid preparation and continuous processing of polylactide stereocomplex crystallite below its melting point, *Polym. Bull.* 96 (2019) 3371–3385.
- [234] A.K. Mohanty, M. Misra, G. Hinrichsen, Biofibres, biodegradable polymers and biocomposites: an overview, *Macromol. Mater. Eng.* 276–277 (2000) 1–24.
- [235] D. Garlotta, A literature review of poly(lactic acid), *J. Polym. Environ.* 9 (2002) 63–84.
- [236] A. Vinod, M.R. Sanjay, S. Suchart, P. Jyotishkumar, Renewable and sustainable biobased materials: an assessment on biofibers, biofilms, biopolymers and biocomposites, *J. Clean. Prod.* 258 (2020) 120978.
- [237] O. Faruk, A.K. Bledzki, H.-P. Fink, M. Sain, Biocomposites reinforced with natural fibers: 2000–2010, *Prog. Polym. Sci.* 37 (2012) 1552–1596.
- [238] M. Jacob, J.S. Thomas, Biofibres and biocomposites, *Carbohydr. Polym.* 71 (2008) 343–364.
- [239] T. Mukherjee, N. Kao, PLA based biopolymer reinforced with natural fibre: a review, *J. Polym. Environ.* 19 (2011) 714.
- [240] H.M. Akil, M.F. Omar, A.A.M. Mazuki, S. Safiee, Z.A.M. Ishak, A. Abu Bakar, Kenaf fiber reinforced composites: a review, *Mater. Des.* 32 (2011) 4107–4121.
- [241] M.M. Kabir, H. Wang, K.T. Lau, F. Cardona, Effect of chemical treatments of hemp fibre structure, *Appl. Surf. Sci.* 276 (2013) 13–23.
- [242] A.A. Yussuf, I. Massoumi, A. Hassan, Comparison of polylactic acid/kenaf and polylactic acid/rise husk composites: the influence of the natural fibers on the mechanical, thermal and biodegradability properties, *J. Polym. Environ.* 18 (2010) 422–429.
- [243] M.R. Kaiser, H.B. Anuar, N.B. Samat, S.B.A. Razak, Effect of processing routes on the mechanical, thermal and morphological properties of PLA-based hybrid biocomposite, *Iran. Polym. J.* 22 (2013) 123–131.
- [244] H. Anuar, A. Zuraida, J.G. Kovacs, T. Tabi, Improvement of mechanical properties of injection-molded polylactic acid-kenaf fiber biocomposite, *J. Thermoplast. Compos. Mater.* 25 (2011) 153–164.
- [245] J. Ganster, H.-P. Fink, M. Pinnow, High-tenacity man-made cellulose fibre reinforced thermoplastics – injection moulding compounds with polypropylene and alternative matrices, *Compos. Part A Appl. Sci. Manuf.* 37 (2006) 1796–1804.
- [246] B. Bax, J. Müssig, Impact and tensile properties of PLA/Cordenka and PLA/flax composites, *Compos. Sci. Technol.* 68 (2008) 1601–1607.
- [247] A.K. Bledzki, A. Jaszkievicz, Mechanical performance of biocomposites based on PLA and PHBV reinforced with natural fibres – a comparative study to PP, *Compos. Sci. Technol.* 70 (2010) 1687–1696.
- [248] A.K. Bledzki, A. Jaszkievicz, D. Scherzer, Mechanical properties of PLA composites with man-made cellulose and abaca fibres, *Compos. Part A Appl. Sci. Manuf.* 40 (2009) 404–412.
- [249] C. Courgneau, D. Rustu, C. Henneuse, V. Duruet, M.-F. Lacrampe, P. Krawczak, Characterization of low-odour emissive polylactide/cellulose fibre biocomposites for car interior, *Express Polym. Lett.* 7 (2013) 787–804.
- [250] M.S. Huda, A.K. Mohanty, L.T. Drzal, E. Schut, M. Misra, “Green” composites from recycled cellulose and poly(lactic acid): physico-mechanical and morphological properties evaluation, *J. Mater. Sci.* 40 (2005) 4221–4229.
- [251] B. Asaithambi, G. Ganesan, S. Ananda Kumar, Bio-composites: development and mechanical characterization of banana/sisal fibre reinforced poly lactic acid (PLA) hybrid composites, *Fibers Polym.* 15 (2014) 847–854.
- [252] N.C. Loureiro, J.L. Esteves, J.C. Viana, S. Ghosh, Development of polyhydroxyalkanoates/poly(lactic acid) composites reinforced with cellulosic fibers, *Compos. B Eng.* 60 (2014) 603–611.
- [253] J. Ganster, H.-P. Fink, M. Pinnow, High-tenacity man-made cellulose fibre reinforced thermoplastics – injection moulding compounds with polypropylene and alternative matrices, *Compos. Part A Appl. Sci. Manuf.* 37 (2006) 1796–1804.
- [254] B. Asaithambi, G. Ganesan, S. Ananda Kumar, Bio-composites: development and mechanical characterization of banana/sisal fibre reinforced poly lactic acid (PLA) hybrid composites, *Fibers Polym.* 15 (2014) 847–854.
- [255] T. Tabi, P. Tamas, J.G. Kovacs, Chopped basalt fibres: a new perspective in reinforcing Poly(lactic acid) to produce injection moulded engineering composites from renewable and natural resources, *Express Polym. Lett.* 7 (2012) 107–119.
- [256] T. Tábi, A.Z. Égerházi, P. Tamás, T. Czirány, J.G. Kovács, Investigation of injection moulded poly(lactic acid) reinforced with long basalt fibres, *Compos. Part A Appl. Sci. Manuf.* 64 (2014) 99–106.
- [257] Y. Wang, B. Tong, S. Hou, M. Li, C. Shen, Transcrystallization behavior at the Poly (lactic acid)/sisal fibre biocomposite interface, *Compos. Part A Appl. Sci. Manuf.* 42 (2011) 66–74.
- [258] A. Orue, A. Eceiza, A. Arbelaz, Preparation and characterization of poly(lactic acid) plasticized with vegetable oils and reinforced with sisal fibers, *Ind. Crop. Prod.* 112 (2018) 170–180.
- [259] H. Huang, L. Chen, G. Song, G. Tang, An efficient plasticization method for poly (lactic acid) using combination of liquid-state and solid-state plasticizers, *J. Appl. Polym. Sci.* 135 (2018) 46669.
- [260] S. Jacobsen, H.G. Fritz, Plasticizing polylactide-the effect of different plasticizers on the mechanical properties, *Polym. Eng. Sci.* 39 (1999) 1303–1310.
- [261] B. Wang, K. Hina, H. Zou, D. Zou, C. Yi, Thermal, crystallization, mechanical and decomposition properties of poly(lactic acid) plasticized with poly(ethylene glycol), *J. Vinyl Addit. Technol.* 24 (2018) E154–E163.
- [262] Z. Lule, H. Ju, J. Kim, Thermomechanical properties of alumina-filled plasticized polylactic acid: effect of alumina loading percentage, *Ceram. Int.* 44 (2018) 22767–22776.
- [263] A. Chaos, A. Sangroniz, J. Fernández, J.d. Río, M. Iriarte, J.R. Sarasua, A. Etxeberria, Plasticization of poly(lactide) with poly(ethylene glycol). Low weight plasticizer vs triblock copolymers, *J. Appl. Polym. Sci.* 137 (2020) 48868.
- [264] E.F. Santos, R.V.B. Oliveira, Q.B. Reitmatt, D. Samois, S.M.B. Nachtigall, Sunflower-oil biodiesel-oligoesters/polylactide blends: plasticizing effect and ageing, *Polym. Test.* 39 (2014) 23–29.
- [265] D.A. D'Amico, M.L. Igelsias Montes, L.B. Manfredi, V.P. Cyras, Fully bio-based and biodegradable polylactic acid/poly(3-hydroxybutyrate) blends: use of a common plasticizer as performance improvement strategy, *Polym. Test.* 49 (2016) 22–28.
- [266] E. Bugnicourt, P. Cinelli, A. Lazzeri, V. Alvarez, Polyhydroxyalkanoate (PHA): review of synthesis, characteristics, processing and potential applications in packaging, *Express Polym. Lett.* 8 (2014) 791–808.
- [267] Z. Li, C. Reimer, T. Wang, A.K. Mohanty, M. Misra, Thermal and mechanical properties of the biocomposites of miscanthus tigrinus and poly(3-hydroxybutyrate-co-3-hydroxyvalerate) (PHBV), *Polymers* 12 (2020) 1300.
- [268] J. Jian, Z. Xiangbin, H. Xianbo, An overview on synthesis, properties and applications of poly(butylene-adipate-co-terephthalate)-PBAT, *Adv. Indus. Eng. Polym. Res.* 3 (2020) 19–26.
- [269] G. Keskin, G. Kizil, M. Bechelany, C. Pochat-Bohatier, M. Oner, Potential of polyhydroxyalkanoate (PHA) polymers family as substitutes of petroleum based polymers for packaging applications and solutions brought by their composites to form barrier materials, *Pure Appl. Chem.* 89 (2017) 1841–1848.
- [270] N. Peelman, P. Ragaert, K. Ragaert, B. De Meulenaer, F. Devlieghere, L. Cardon, Heat resistance of new biobased polymeric materials, focusing on starch, Cellulose, PLA, PHA, Special Issue: Manufact. Adv. Biodegr. Polym. Comp. 132 (2015) 1–15.

- [271] A. El-Hadi, R. Schnabel, E. Straube, G. Müller, S. Henning, Correlation between degree of crystallinity, morphology, glass temperature, mechanical properties and biodegradation of poly (3-hydroxyalkanoate) PHAs and their blends, *Polymer Testing* 21 (2002) 665–674.
- [272] E. Hassan, Y. Wei, H. Jiao, Y. Muhuo, Dynamic mechanical properties and thermal stability of poly(lactic acid) and poly(butylene succinate) blends composites, *J. Fiber Bioeng. Inf.* 6 (2013) 85–94.
- [273] R. Homklin, N. Hongsriphan, Mechanical and thermal properties of PLA/PBS co-continuous blends adding nucleating agent, *Energy Procedia*, 34 (34), 871–879.
- [274] A.K. Matta, R.U. Rao, K.N.S. Suman, V. Rambabu, Preparation and characterization of biodegradable PLA/PCL polymeric blends, *Procedia Mat. Sci.* 6 (2014) 1266–1270.
- [275] J.P. Mofokeng, A.S. Luyt, Morphology and thermal degradation studies of melt-mixed poly(lactic acid) (PLA)/poly(ϵ -caprolactone) (PCL) biodegradable polymer blend nanocomposites with TiO₂ as filler, *Polym. Test.* 45 (2015) 93–100.
- [276] J.P. Mofokeng, A.S. Luyt, Dynamic mechanical properties of PLA/PHBV, PLA/PCL, PHBV/PCL blends and their nanocomposites with TiO₂ as nanofiller, *Thermochim. Acta* 613 (2015) 41–53.
- [277] D. Battagazzore, S. Bocchini, A. Frache, Crystallization kinetics of poly(lactic acid)-talc composites, *Express Polym. Lett.* 5 (2011) 849–858.
- [278] A.M. Harris, E.C. Lee, Improving mechanical performance of injection molded PLA by controlling crystallinity, *Appl. Polym. Sci.* 107 (2008) 2246–2255.
- [279] L. Wen, Z. Xin, Effect of a novel nucleating agent on isothermal crystallisation of poly(L-lactic acid), *Chin. J. Chem. Eng.* 18 (2010) 899–904.
- [280] A. Shakoob, N.L. Thomas, Talc as a nucleating agent and reinforcing filler in poly(lactic acid) composites, *Polym. Eng. Sci.* 54 (2013) 64–70.
- [281] Y.-H. Cai, Crystallization and melting behavior of biodegradable poly(L-lactic acid)/talc composites, *E-J. Chem.* 9 (2012) 1569–1574.
- [282] P. Pan, Z. Liang, A. Cao, Y. Inoue, Layered metal phosphonate reinforced poly(L-lactide) composites with a highly enhanced crystallization rate, *ACS Appl. Mater. Interfaces* 1 (2009) 402–411.
- [283] P. Song, G. Chen, Z. Wei, Y. Chang, W. Zhang, J. Liang, Rapid crystallization of poly(L-lactic acid) induced by a nano-sized zinc citrate complex as nucleating agent, *Polym* 53 (2012) 4300–4309.
- [284] K.S. Kang, S.I. Lee, T.J. Lee, R. Narayan, B.Y. Shin, Effect of biobased and biodegradable nucleating agent on the isothermal crystallization of poly(lactic acid), *Kor. J. Chem. Eng.* 25 (2008) 599–608.
- [285] M. Li, D. Hu, Y. Wang, C. Shen, Nonisothermal crystallization kinetics of poly(lactic acid) formulations comprising talc with poly(ethylene glycol), *Polym. Eng. Sci.* 50 (2010) 2298–2305.
- [286] H. Tsuji, H. Takai, N. Fukuda, H. Takikawa, Non-isothermal crystallization behavior of poly(L-lactic acid) in the presence of various additives, *Macromol. Mater. Eng.* 291 (2006) 325–335.
- [287] P. Pan, J. Yang, G. Shan, Y. Bao, Z. Weng, Y. Inoue, Nucleation effects of nucleobases on the crystallization kinetics of poly(L-lactide), *Macromol. Mater. Eng.* 297 (2012) 670–679.
- [288] M. Penco, G. Spagnoli, I. Peroni, M.A. Rahman, M. Frediani, W. Oberhauser, A. Lazzeri, Effect of nucleating agents on the molar mass distribution and its correlation with the isothermal crystallization behavior of poly(L-lactic acid) *Appl. Polym. Sci. Spec. Issue: Contrib. 5th Int. Conf. Times Polym. Comp.* 122 (2010) 3528–3536. Ischia, Italy, June 20–23.
- [289] H. Urayama, T. Kanamori, K. Fukushima, Y. Kimura, Controlled crystal nucleation in the melt-crystallization of poly(L-lactide) and poly(l-lactide)/poly(d-lactide) stereocomplex, *Polym* 44 (2011) 5635–5641.
- [290] M. Nofar, A. Tabatabaei, C.B. Park, Effects of nano-/micro-sized additives on the crystallization behaviors of PLA and PLA/CO₂ mixtures, *Polym* 54 (2013) 2382–2391.
- [291] Y. Li, C. Han, L. Xiao, Y. Shao, Effect of content and particle size of talc on nonisothermal melt crystallization behavior of poly(l-lactide), *J. Therm. Anal. Calorim.* 135 (2019) 2049–2058.
- [292] L. Chen, Q. Dou, Influence of the combination of nucleating agent and plasticizer on the non-isothermal crystallization kinetics and activation energies of poly(lactic acid), *J. Therm. Anal. Calorim.* 139 (2020) 1069–1090.
- [293] S. Barrau, C. Vanmansart, M. Moreau, A. Addad, G. Stoclet, J.-M. Lefebvre, R. Seguela, Crystallization behavior of carbon nanotube–poly(lactide) nanocomposites, *Macromolecules* 44 (2011) 6496–6502.
- [294] H.-S. Xu, X.J. Dai, P.R. Lamb, Z.-M. Li, Poly(L-lactide) crystallization induced by multiwall carbon nanotubes at very low loading, *J. Polym. Sci., Part B: Polym. Phys.* 47 (2009) 2341–2352.
- [295] G.Z. Papageorgiou, D.S. Achilias, S. Nanaki, T. Beslikas, D. Bikiaris, PLA nanocomposites: effect of filler type on non-isothermal crystallization, *Thermochim. Acta* 511 (2010) 129–139.
- [296] Y. Zhao, Z. Qiu, W. Yang, Effect of functionalization of multiwalled nanotubes on the crystallization and hydrolytic degradation of biodegradable poly(l-lactide), *J. Phys. Chem. B* 112 (2008) 16461–16468.
- [297] Y. Zhao, Z. Qiu, W. Yang, Effect of multi-walled carbon nanotubes on the crystallization and hydrolytic degradation of biodegradable poly(l-lactide), *Compos. Sci. Technol.* 69 (2009) 627–632.
- [298] S.H. Park, S.G. Lee, S.H. Kim, Isothermal crystallization behavior and mechanical properties of poly(lactide)/carbon nanotube nanocomposites, *Compos. Part A Appl. Sci. Manuf.* 46 (2013) 11–18.
- [299] Z. Xu, Y. Niu, Z. Wang, H. Li, L. Yang, J. Qui, H. Wang, Enhanced nucleation rate of polylactide in composites assisted by surface acid oxidized carbon nanotubes of different aspect ratios, *ACS Appl. Mater. Interfaces* 3 (2011) 3744–3753.
- [300] J.Y. Nam, S.S. Ray, M. Okamoto, Crystallization behavior and morphology of biodegradable polylactide/layered silicate nanocomposite, *Macromolecules* 36 (2003) 7126–7131.
- [301] N. Kawamoto, A. Sakai, T. Horikoshi, T. Urushihara, E. Tobita, Nucleating agent for poly(L-lactic acid)—an optimization of chemical structure of hydrazide compound for advanced nucleation ability, *J. Appl. Polym. Sci.* 103 (2006) 198–203.
- [302] Y. Wang, D. He, X. Wang, W. Cao, Q. Li, C. Shen, Crystallization of poly(lactic acid) enhanced by phthalhydrazide as nucleating agent, *Polym. Bull.* 70 (2013) 2911–2922.
- [303] Y.-H. Cai, Synthesis, thermal properties and nucleating effect of N, N, N, N'-Tetra (benzoyl) ethylene diamine tetraacetic acid dihydrazide as nucleating agent of poly(L-lactic acid), *E-J. Chem.* 9 (2012) 1575–1580.
- [304] Y. Cai, S. Yan, J. Yin, Y. Fan, X. Chen, Crystallization behavior of biodegradable poly(L-lactic acid) filled with a powerful nucleating agent: N,N'-bis(benzoyl) suberic acid dihydrazide, *J. Appl. Polym. Sci.* 121 (2011) 1408–1416.
- [305] N. Kawamoto, A. Sakai, T. Horikoshi, T. Urushihara, E. Tobita, Physical and mechanical properties of poly(L-lactic acid) nucleated by dibenzoylhydrazide compound, *Appl. Polym. Sci.* 103 (2006) 244–250.
- [306] H. Bai, C. Huang, H. Xiu, Q. Zhang, Q. Fu, Enhancing mechanical performance of polylactide by tailoring crystal morphology and lamellae orientation with the aid of nucleating agent, *Polym* 55 (2014) 6924–6934.
- [307] H. Tsuji, H. Takai, S.K. Saha, Isothermal and non-isothermal crystallization behavior of poly(L-lactic acid): effects of stereocomplex as nucleating agent, *Polym* 47 (2006) 3826–3837.
- [308] K.S. Anderson, M.A. Hillmyer, Melt preparation and nucleation efficiency of polylactide stereocomplex crystallites, *Polym* 47 (2006) 2030–2035.
- [309] Z. Tang, C. Zhang, X. Liu, J. Zhu, The crystallization behavior and mechanical properties of polylactide in the presence of a crystal nucleating agent, *J. Appl. Polym. Sci.* 125 (2012) 1108–1115.
- [310] J.Y. Nam, M. Okamoto, H. Okamoto, M. Nakano, A. Usuki, M. Matsuda, Morphology and crystallization kinetics in a mixture of low-molecular weight aliphatic amide and polylactide, *Polym* 47 (2006) 1340–1347.
- [311] Q. Xing, X. Zhang, X. Dong, G. Liu, D. Wang, Low-molecular weight aliphatic amides as nucleating agents for poly(L-lactic acid): conformation variation induced crystallization enhancement, *Polym* 53 (2012) 2306–2314.
- [312] K. Fukushima, A. Fina, F. Geobaldo, A. Venturello, G. Camino, Properties of Poly(lactic acid) nanocomposites based on montmorillonite, sepiolite and zirconium phosphonate, *Express Polym. Lett.* 6 (2012) 914–926.
- [313] K. Fukushima, D. Tabuani, G. Camino, Poly(lactic acid)/clay nanocomposites: effect of nature and content of clay on morphology, thermal and thermomechanical properties, *Mater. Sci. Eng. C* 32 (2012) 1790–1795.
- [314] J.-J. Hwang, S.-M. Huang, H.-J. Liu, H.-C. Chu, L.-H. Lin, C.-S. Chung, Crystallization kinetics of poly(L-lactic acid)/montmorillonite nanocomposites under isothermal crystallization condition, *J. Appl. Polym. Sci.* 124 (2012) 2216–2226.
- [315] L. Wang, Y.-n. Wang, Z.-g. Huang, Y.-x. Weng, Heat resistance, crystallization behavior, and mechanical properties of polylactide/nucleating agent composites, *Mater. Des.* 66 (2015) 7–15.
- [316] Z. Gui, C. Lu, S. Cheng, Comparison of the effects of commercial nucleation agents on the crystallization and melting behaviour of polylactide, *Polym. Test.* 32 (2013) 15–21.
- [317] Z. Wei, P. Song, J. Linag, G. Chen, W. Zhang, Enhanced Crystallization of Polylactide by Adding a Multiamide Compound, *SPE Plast. Res. Online*, 2011, pp. 1–3.
- [318] H. Bai, W. Zhang, H. Deng, Q. Zhang, Q. Fu, Control of crystal morphology in poly(l-lactide) by adding nucleating agent, *Macromolecules* 44 (2011) 1233–1237.
- [319] P. Song, Z. Wei, J. Liang, G. Chen, W. Zhang, Crystallization behavior and nucleation analysis of poly(l-lactic acid) with a multiamide nucleating agent, *Polym. Eng. Sci.* 52 (2012) 1058–1068.
- [320] S. Wang, C. Han, J. Bian, L. Han, X. Wang, L. Dong, Morphology, crystallization and enzymatic hydrolysis of poly(L-lactide) nucleated using layered metal phosphonates, *Polym. Int.* 60 (2011) 284–295.
- [321] L. Han, C. Han, J. Bian, Y. Bian, H. Lin, X. Wang, H. Zhang, L. Dong, Preparation and characteristics of a novel nano-sized calcium carbonate (nano-CaCO₃)-supported nucleating agent of poly(L-lactide), *Polym. Eng. Sci.* 52 (2012) 1474–1484.
- [322] K. Shinyama, T. Oi, S. Fujita, Electrical properties of polylactic acid with nucleating agent added, *Electr. Eng. Jpn.* 180 (2012) 427–432.
- [323] P. Chen, H. Zhou, W. Liu, M. Zhang, Z. Du, X. Wang, The synergistic effect of zinc oxide and phenylphosphonic acid zinc salt on the crystallization behavior of poly(lactic acid), *Polym. Degrad. Stabil.* 122 (2015) 25–35.
- [324] T.-C. Yang, K.-C. Hung, T.-L. Wu, T.-M. Wu, J.-H. Wu, A comparison of annealing process and nucleating agent (zinc phenylphosphonate) on the crystallization, viscoelasticity, and creep behavior of compression-molded poly(lactic acid) blends, *Polym. Degrad. Stabil.* 121 (2015) 230–237.
- [325] P. Chen, K. Yu, Y. Wang, W. Wang, H. Zhou, H. Li, J. Mi, X. Wang, The effect of composite nucleating agent on the crystallization behavior of branched poly(lactic acid), *J. Polym. Environ.* 26 (2018) 3718–3730.
- [326] Z. Qiu, H. Pan, Preparation, crystallization and hydrolytic degradation of biodegradable poly(l-lactide)/polyhedral oligomeric silsesquioxanes nanocomposite, *Compos. Sci. Technol.* 70 (2010) 1089–1094.
- [327] J. Yu, Z. Qiu, Effect of low octavinyl-polyhedral oligomeric silsesquioxanes loadings on the melt crystallization and morphology of biodegradable poly(L-lactide), *Thermochim. Acta* 519 (2011) 90–95.

- [328] J. Yu, Z. Qiu, Preparation and properties of biodegradable poly(L-lactide)/octamethyl-polyhedral oligomeric silsesquioxanes nanocomposites with enhanced crystallization rate via simple melt compounding, *ACS Appl. Mater. Interfaces* 3 (2011) 890–897.
- [329] H. Pan, Z. Qiu, Biodegradable poly(L-lactide)/polyhedral oligomeric silsesquioxanes nanocomposites: enhanced crystallization, mechanical properties, and hydrolytic degradation, *Macromolecules* 43 (2010) 1499–1506.
- [330] J. Yu, Z. Qiu, Isothermal and nonisothermal cold crystallization behaviors of biodegradable poly(L-lactide)/octavinyl-polyhedral oligomeric silsesquioxanes nanocomposites, *Ind. Eng. Chem. Res.* 50 (2011) 12579–12586.
- [331] M. Kodal, H. Sirin, G. Ozkoc, Investigation of relationship between crystallization kinetics and interfacial interactions in plasticized poly(lactic acid)/POSS nanocomposites: “Effects of different POSS types”, *Polym. Compos.* 39 (2016) 2674–2684.
- [332] E.d.M. Teixeira, A.A.S. Curvelo, A.C. Corrêa, J.M. Marconcini, G.M. Glenn, L.H. C. Mattoso, Properties of thermoplastic starch from cassava bagasse and cassava starch and their blends with poly(lactic acid), *Ind. Crop. Prod.* 37 (2012) 61–68.
- [333] J. Cai, M. Liu, L. Wang, K. Yao, S. Li, H. Xiong, Isothermal crystallization kinetics of thermoplastic starch/poly(lactic acid) composites, *Carbohydr. Polym.* 86 (2011) 941–947.
- [334] T. Ke, X. Sun, Melting behavior and crystallization kinetics of starch and poly(lactic acid) composites, *J. Appl. Polym. Sci.* 89 (2003) 1203–1210.
- [335] L. Suryanegara, A.N. Nakagaito, H. Yano, The effect of crystallization of PLA on the thermal and mechanical properties of microfibrillated cellulose-reinforced PLA composites, *Compos. Sci. Technol.* 69 (2009) 1187–1192.
- [336] A.N. Frone, S. Berlioz, J.-F. Chailan, D.M. Panaitescu, Morphology and thermal properties of PLA–cellulose nanofibers composites, *Carbohydr. Polym.* 91 (2013) 377–384.
- [337] A. Pei, Q. Zhou, L.A. Berglund, Functionalized cellulose nanocrystals as biobased nucleation agents in poly(L-lactide) (PLLA) – crystallization and mechanical property effects, *Compos. Sci. Technol.* 70 (2010) 815–821.
- [338] D. Bagheriasl, P.J. Carreau, B. Riedl, C. Dubois, Enhanced properties of polylactide by incorporating cellulose nanocrystals, *Polym. Compos.* 39 (2018) 2685–2694.
- [339] H. Wang, Z. Qiu, Crystallization kinetics and morphology of biodegradable poly(L-lactic acid)/graphene oxide nanocomposites: influences of graphene oxide loading and crystallization temperature, *Thermochim. Acta* 527 (2012) 40–46.
- [340] L. Hua, W. Kai, J. Yang, Y. Inoue, A new poly(L-lactide)-grafted graphite oxide composite: facile synthesis, electrical properties and crystallization behaviors, *Polym. Degrad. Stabil.* 95 (2010) 2619–2627.
- [341] L. Wen, Z. Xin, D. Hu, A new route of manipulation of poly(L-lactic acid) crystallization by self-assembly of p-tert-butylcalix[8]arene and toluene, *J. Polym. Sci., Part B: Polym. Phys.* 48 (2010) 1235–1243.
- [342] R. Liao, B. Yang, W. Yu, C. Zhou, Isothermal cold crystallization kinetics of polylactide/nucleating agents, *J. Appl. Polym. Sci.* 104 (2007) 310–317.
- [343] Y. Li, C. Chen, J. Li, X.S. Sun, Isothermal crystallization and melting behaviors of bionanocomposites from poly(lactic acid) and TiO₂ nanowires, *J. Appl. Polym. Sci.* 124 (2012) 2968–2977.
- [344] S. Saeidlou, M.A. Huneault, H. Li, C.B. Park, Effect of nucleation and plasticization on the stereocomplex formation between enantiomeric poly(lactic acid)s, *Polym* 54 (2013) 5762–5770.
- [345] B. Wen, L. Ma, X. Zheng, Enhanced thermal conductivity of poly(lactic acid)/alumina composite by synergistic effect of tuning crystallization of poly(lactic acid) crystallization and filler content, *J. Mater. Sci. Mater. Electron.* 31 (2020) 6328–6338.
- [346] K. Li, W. Zhen, Performance, structure-property relationship and biodegradability of poly(lactic acid)/amide ammonium acetate organic vermiculite intercalation nanocomposites, *Polym. Plast. Technol. Mat.* 59 (2020) 702–721.
- [347] J.-N. Yang, S.-B. Nie, Y.-H. Qiao, Y. Liu, Z.-Y. Li, G.-J. Cheng, Crystallization and rheological properties of the eco-friendly composites based on poly(lactic acid) and precipitated barium sulfate, *J. Polym. Environ.* 27 (2019) 2739–2755.
- [348] Y. Xu, L. Wu, Synthesis of organic bisurea compounds and their roles as crystallization nucleating agents of poly(L-lactic acid), *Eur. Polym. J.* 49 (2013) 865–872.
- [349] C. Li, Q. Dou, Z. Bai, Q. Lu, Non-isothermal crystallization behaviors and spherulitic morphology of poly(lactic acid) nucleated by a novel nucleating agent, *J. Therm. Anal. Calorim.* 122 (2015) 407–417.
- [350] Z. Su, W. Guo, Y. Liu, Q. Li, C. Wu, Non-isothermal crystallization kinetics of poly(lactic acid)/modified carbon black composite, *Polym. Bull.* 62 (2009) 629–642.
- [351] P.C. Dartora, M. da Rosa Loureiro, M.M. da Camargo Forte, Crystallization kinetics and morphology of poly(lactic acid) with polysaccharide as nucleating agent, *J. Therm. Anal. Calorim.* 134 (2018) 1705–1713.
- [352] M.R. Kamal, V. Khoshkava, Effect of cellulose nanocrystals (CNC) on rheological and mechanical properties and crystallization behavior of PLA/CNC nanocomposites, *Carbohydr. Polym.* 123 (2015) 105–114.
- [353] E. Lizundia, J.L. Vilas, L.M. León, Crystallization, structural relaxation and thermal degradation in Poly(L-lactide)/cellulose nanocrystal renewable nanocomposites, *Carbohydr. Polym.* (2015) 256–265.
- [354] E. Lizundia, E. Fortunati, F. Dominici, J.L. Vilas, L.M. León, I. Armentano, L. Torre, J.M. Kenny, PLLA-grafted cellulose nanocrystals: role of the CNC content and grafting on the PLA bionanocomposite film properties, *Carbohydr. Polym.* 142 (2016) 105–113.
- [355] W. Ding, D. Jahani, E. Chang, A. Alemdar, C.B. Park, M. Sain, Development of PLA/cellulosic fiber composite foams using injection molding: crystallization and foaming behaviors, *Compos. Appl. Sci. Manuf.* 83 (2016) 130–139.
- [356] M. Day, A.V. Nawaby, X. Liao, A DSC study of the crystallization behaviour of polylactic acid and its nanocomposites, *J. Therm. Anal. Calorim.* 86 (2006) 623–629.
- [357] M. Weng, Z. Qiu, Effect of cyanuric acid on the crystallization kinetics and morphology of biodegradable poly(L-lactide) as an efficient nucleating agent, *Thermochim. Acta* 577 (2014) 41–45.
- [358] C. Li, Q. Dou, Non-isothermal crystallization kinetics and spherulitic morphology of nucleated poly(lactic acid): effect of dilithium hexahydrophthalate as a novel nucleating agent, *Thermochim. Acta* 594 (2014) 31–38.
- [359] P. Liu, W. Zheng, Structure-property relationship, rheological behavior, and thermal degradability of poly(lactic acid)/fulvic acid amide composites, *Polym. Adv. Technol.* 29 (2018) 2192–2203.
- [360] K. Duan, W. Zhen, The synthesis of fulvic acid–thiourea amide derivatives grafted polystyrene and its effect on the crystallization and performance of poly(lactic acid), *Polym. Eng. Sci.* 59 (2019) 1787–1798.
- [361] D. Wu, Y. Cheng, S. Feng, Z. Yao, M. Zhang, Crystallization behavior of polylactide/graphene composites, *Ind. Eng. Chem. Res.* 52 (2013) 6731–6739.
- [362] B. Yang, D. Wang, F. Cheng, J.-S. Qian, R. Xia, J.-W. Liu, Melting and crystallization behaviors of poly(lactic acid) modified with graphene acting as a nucleating agent, *J. Macromol. Sci. Part B* 58 (2019) 290–304.
- [363] D. Wu, H. Guo, R. Zhang, H.-Z. Cui, H.-Z. Cui, Enhanced crystallization properties of poly(lactic acid) nanocomposites assisted by poly(amidoamine) functionalized graphene oxide, *ECS J. Solid State Sci. Technol.* 7 (2018) M139–M144.
- [364] N. Naga, Y. Yoshida, K. Noguchi, S. Murase, Crystallization of amorphous poly(lactic acid) induced by vapor of acetone to form high crystallinity and transparency specimen, *Open J. Polym. Chem.* 3 (2013) 29–33.
- [365] S. Qin, Y. Hu, X. Tian, Y. Tian, W. Liu, L. Zhao, Modification of cellulose nanocrystals by self-assembly nucleation agents to improve poly(L-lactide) nanocomposite properties, *Cellulose* 27 (2020) 4337–4353.
- [366] A. Kovalcik, R.A. Pérez-Camargo, C. Fürst, P. Kucharczyk, A.J. Müller, Nucleating efficiency and thermal stability of industrial non-purified lignin and ultrafine talc in poly(lactic acid) (PLA), *Polym. Degrad. Stabil.* 142 (2017) 244–254.
- [367] Y. Feng, P. Ma, P. Xu, R. Wang, W. Dong, M. Chen, C. Joziassé, The crystallization behavior of poly(lactic acid) with different types of nucleating agents, *Int. J. Biol. Macromol.* 106 (2018) 955–962.
- [368] Y. Phuphuak, S. Chirachanchai, Simple preparation of multi-branched Poly(L-lactic acid) and its role as nucleating agent for Poly(lactic acid), *Polym* 54 (2013) 572–582.
- [369] Y. Tachibana, T. Maeda, O. Ito, Y. Maeda, M. Kunioka, Biobased myo-inositol as nucleator and stabilizer for poly(lactic acid), *Polym. Degrad. Stabil.* 95 (2010) 1321–1329.
- [370] C. Delabarde, C.J.G. Plummer, P.E. Bourban, J.A.E. Manson, Solidification behavior of PLLA/nHA nanocomposites, *Compos. Sci. Technol.* 70 (2010) 1813–1819.
- [371] J. Li, D. Chen, B. Gui, M. Gu, J. Ren, Crystallization morphology and crystallization kinetics of poly(lactic acid): effect of N-Aminophthalimide as nucleating agent, *Polym. Bull.* 67 (2011) 775–791.
- [372] N. Leone, M. Roy, S. Saidi, G. de Kort, D. Hamida-Merino, C.H.R.M. Wilsen, Improving processing, crystallization, and performance of poly-L-lactide with an amide-based organic compound as both plasticizer and nucleating agent, *ACS Omega* 4 (2019) 10376–10387.
- [373] Z. Zhen, Q. Xing, R. Li, X. Dong, Crystallization behavior of polylactide nucleated by octamethylenedicarboxylic di(2-hydroxybenzohydrazide): solubility influence, *Thermochim. Acta* 683 (2020) 178447.
- [374] Z. Qui, Z. Li, Effect of orotic acid on the crystallisation kinetics and morphology of biodegradable poly(L-lactide) as an efficient nucleating agent, *Ind. Eng. Chem. Res.* 50 (2011) 12299–12303.
- [375] M. Roy, M. Zhelezniakov, G.W. de Kort, L.G.D. Hawke, N. Leone, S. Rastogi, C.H. R.M. Wilsen, On the Nucleation of Polylactide by Melt-Soluble Oxalamide Based Organic Compounds, *Polym.*, 2020, p. 122680.
- [376] S. Karimi, I. Ghasemi, F. Abbassi-Sourki, A study on the crystallization kinetics of PLLA in the presence of Graphene Oxide and PEG-grafted-Graphene Oxide: effects on the nucleation and chain mobility, *Compos. B Eng.* 158 (2019) 302–310.
- [377] H. Tsuji, K. Tashiro, L. Bouapao, J. Narita, Polyglycolide as a biodegradable nucleating agent for poly(L-lactide), *Macromol. Mater. Eng.* 293 (2008) 947–951.
- [378] D. He, Y. Wang, C. Shao, G. Zheng, Q. Li, C. Shen, Effect of phthalimide as an efficient nucleating agent on the crystallization kinetics of poly(lactic acid), *Polym. Test.* 32 (2013) 1088–1093.
- [379] B. Li, F.-X. Dong, X.-L. Wang, J. Yang, D.-Y. Wang, Y.-Z. Wang, Organically modified rectorite toughened poly(lactic acid): nanostructures, crystallization and mechanical properties, *Eur. Polym. J.* 45 (2009) 2996–3003.
- [380] S. Ouchiar, G. Stoclet, C. Cabaret, E. Georges, A. Smith, C. Martias, A. Addad, V. Gloaguen, Comparison of the influence of talc and kaolinite as inorganic fillers on morphology, structure and thermomechanical properties of polylactide based composites, *Appl. Clay Sci.* 116–117 (2015) 231–240.
- [381] N.G.V. Fundador, Y. Enomoto-Rogers, A. Takemura, T. Iwata, Xylan esters as biobased nucleating agents for poly(L-lactic acid), *Polym. Degrad. Stabil.* 98 (2013) 1064–1071.
- [382] R. Zhang, Y. Wang, K. Wang, G. Zheng, Q. Li, C. Shen, Crystallization of poly(lactic acid) accelerated by cyclodextrin complex as nucleating agent, *Polym. Bull.* 70 (2013) 195–206.
- [383] J. You, W. Yu, C. Zhou, Accelerated crystallization of poly(lactic acid): synergistic effect of poly(ethylene glycol), dibenzylidene sorbitol, and long-chain branching, *Ind. Eng. Chem. Res.* 53 (2014) 1097–1107.

- [384] R. Somsunan, N. Mainoiy, Isothermal and non-isothermal crystallization kinetics of PLA/PBS blends with talc as nucleating agent, *J. Therm. Anal. Calorim.* 139 (2020) 1941–1948.
- [385] Z. Qiu, Z. Li, Effect of orotic acid on the crystallization kinetics and morphology of biodegradable poly(l-lactide) as an efficient nucleating agent, *Ind. Eng. Chem. Res.* 50 (2011) 12299–12303.
- [386] H. Li, M.A. Huneault, Effect of nucleation and plasticization on the crystallization of poly(lactic acid), *Polym* 48 (2007) 6855–6866.
- [387] V. Nagarajan, K. Zhang, M. Misra, A.K. Mohanty, Overcoming the fundamental challenges in improving the impact strength and crystallinity of PLA biocomposites: influence of nucleating agent and mold temperature, *ACS Appl. Mater. Interfaces* 7 (2015) 11203–11214.
- [388] S. Motru, V.H. Adithyakrishna, J. Bharatha, R. Guruprasad, Development and evaluation of mechanical properties of biodegradable PLA/flax fiber green composite laminates, *Mater. Today Proc.* 24 (2020) 641–649.
- [389] K. Immonen, U. Anttila, L. Wikstrom, Coupling of PLA and bleached softwood kraft pulp (BSKP) for enhanced properties of biocomposites, *J. Thermoplast. Compos. Mater.* 1–14 (2018) 14.
- [390] S. Chaitanya, I. Singh, Ecofriendly treatment of aloe vera fibers for PLA based green composites, *Int. J. Precis. Eng. Manuf.* 5 (2018) 143–150.
- [391] H. Long, Z. Wu, Q. Dong, Y. Shen, W. Zhou, Y. Luo, C. Zhang, X. Dong, Effect of polyethylene glycol on mechanical properties of bamboo fiber-reinforced polylactic acid composites, *J. Appl. Polym. Sci.* 136 (2019) 47709.
- [392] H. Peltola, K. Immonen, L.-S. Johansson, J. Virkajärvi, D. Sandquist, Influence of pulp bleaching and compatibilizer selection on performance of pulp fiber reinforced PLA biocomposites, *J. Appl. Polym. Sci.* 136 (2019) 47955.
- [393] Z. Samouth, L. Molnar, F. Boussu, O. Cherkaoui, R. El Moznine, Mechanical and thermal characterization of sisal fiber reinforced polylactic acid composites, *Polym. Adv. Technol.* 30 (2019) 529–537.
- [394] H. Zhang, Y. Li, G. Yang, M. Yu, H. Shao, Effect of interfacial modification on the thermo-mechanical properties of flax reinforced polylactide stereocomplex composites, *J. Polym. Eng.* 40 (2020) 403–408.
- [395] U.K. Komal, M.K. Lila, I. Singh, PLA/banana fiber based sustainable biocomposites: a manufacturing perspective, *Compos. B Eng.* 180 (2020) 107535.
- [396] A. Orue, A. Eceiza, A. Arbelaz, The use of alkali treated walnut shells as filler in plasticized poly(lactic acid) matrix composites, *Ind. Crop. Prod.* 145 (2020) 111993.
- [397] T. Tábi, I.E. Sajó, F. Szabó, A.S. Luyt, J.G. Kovács, Crystalline structure of annealed polylactic acid and its relation to processing, *Express Polym. Lett.* 4 (2010) 659–668.