

Artificial Education Process Environment for Embedded Systems

György Györök, Bertalan Beszedes
 Alba Regia Technical Faculty
 Óbuda University
 Budai Str. 45, H-8000 Székesfehérvár
 {gyorok.gyorgy, bertalan.beszedes}@amk.uni-obuda.hu

Abstract—The pragmatic engineer science education is essential that it is occurring in the industry, and industrial applications and examples of close-add tasks to the students that have knowledge of the method of accounting experience is going. The embedded microcontroller current teaching of particular importance is how to create a microcontroller environment, wherein the controlled process, the actuators and sensors can show practical solutions. For these reasons, the students with respect to certain programming, hardware fitting task is not only emulated, simulated results can be seen within the environment, but close to moving, active process models can work.

I. INTRODUCTION

Each microcontroller manufacturer believes it is important to meet the various needs of the users to the greatest extent possible. This was too easy to use development environment available for all program details beyond a so-called toolkit are a distributor of microcontrollers with a minimum configuration embedded in the environment are able to operate. These small developer implements a few simple peripheral side of the actuator and the sensor. Output peripherals are usually some LEDs, less dot-matrix or seven-segment display occurs while the input side of the sensors may frequently switches, potentiometers.

The microcontrollers such an environment, of course, highly programmable, but a functional feature is only conceivable in a great empathy. Students will assume the part of big-big imagination. Have the chance to experience the solution when a process or positioning of moving parts, operation must be carried out.

The whole process can be seen.

On Fig.1 is seen the traditional connection between a microcontroller and an average plant. The microcontroller trough an interface circuit as input output devices is connected (Λ), to the environment. Are there any connection form interface card to the plant on low power surface (α), and to the actuators (δ), and the sensors (τ). The α there are such surface which on native voltage on current of microcontroller connect to the appropriate points of the plant, with over voltage and over current protection. But the sensors and actuators moreover makes physical transformation also most of application, and the necessaries level fitting [7][5].

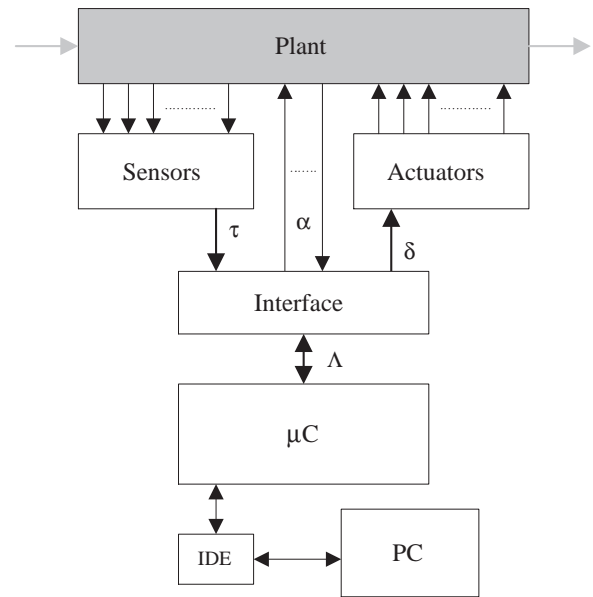

Fig. 1. The traditional connection between the microcontroller and development tools.

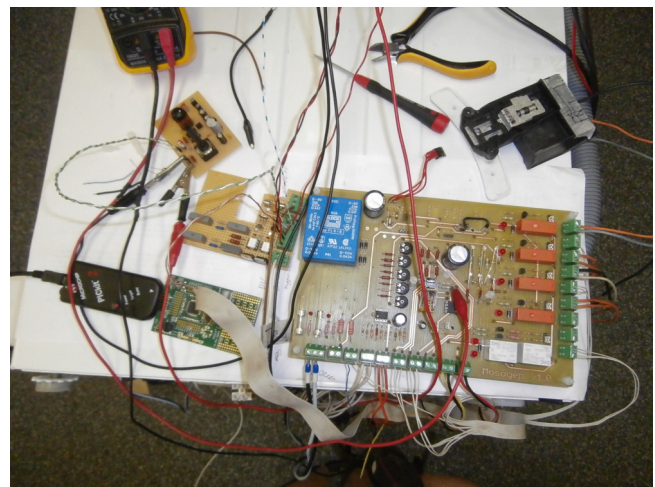

Fig. 2. Interface card between washing machine and PIC 16F887 microcontroller.

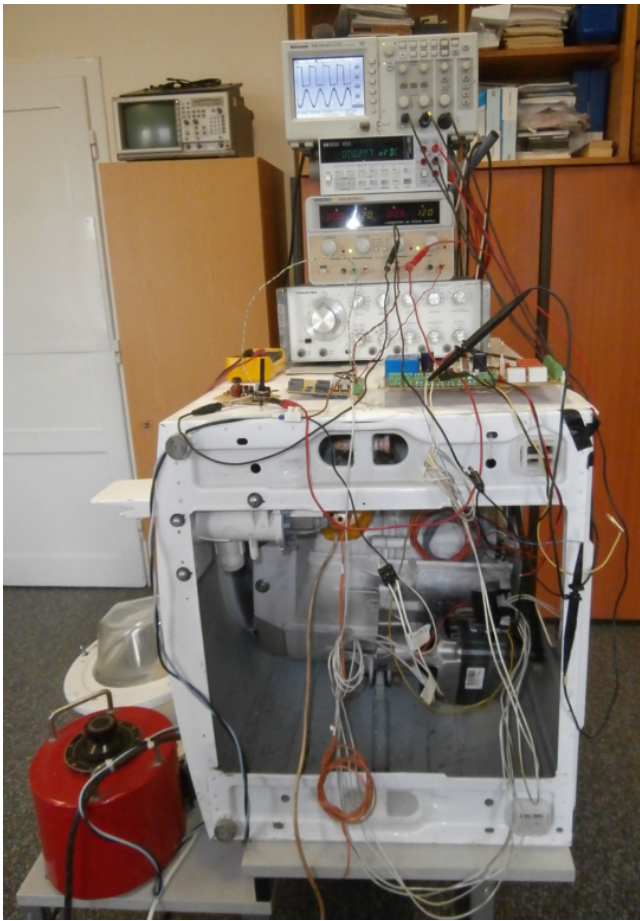

Fig. 3. Washing machine in test environment.

II. DESCRIPTION OF TECHNICAL ENVIRONMENT

The washing machine have got a few input peripherals like the main-motor, the pump, door interlock and the solenoids, and some output peripherals like the NTC resistor and the pressure sensor (Fig. 2, Fig. 3).

a) Main-motor: For power purposes uses a cage induction series-wound AC motor, which ensures a high starting torque. In serial connection the number of turns of the field coil and the resistance is low, so the armature current is not limited. At starting, when no inner voltage is inducted, the motor's current will be very big. During rotation, the induced voltage reduces the current, the result is a reducing winding and only in larger speed will the inner voltage and the terminal voltage equal. That is why the motor rotation speed is growing. The winding current is continue to fall, so the speed tends to infinity. In practice, the friction and drag it limits to access, but it still can cause damage in high RPM. A series-wound motor can not be switched on without a load or we need to adjust the speed. The cage consists of an aluminum alloy, which is generated by pouring the rotor's iron body's grooves. The motor coil is replaced by interconnected rods, which have got small induced voltage, but resistance also smaller, so there can flow extremely large current. The motor pulley and the drum



Fig. 4. The main motor and connection of heating body.

pulley are fitted with elastic drive belts. The motor is mounted in a fixed position, and no regulation is possible (Fig. 4)

b) Drain pump: The function of the drain pump is to discharge the water at the end of each phase of the washing cycle. These centrifugal pumps are actioned by a synchronous motor. The stator is a phase coil, the rotor consists of a permanent magnet and may rotate in either direction. The rotor may rotate for approximately 15 minutes without actioning the impeller. As a result, if the impeller is jammed by a foreign body, the rotor may perform short clockwise and anti-clockwise movements until the blockage is removed.

c) Solenoid valve: The solenoid valve ducts water through the detergent dispenser. When at rest, the core, upon which pressure is exerted by a spring, holds the hole in the centre of the membrane closed; as a result, the membrane hermetically closes off access to the water intake duct. When the coil is powered, it attracts the core, which therefore opens the small hole in the centre of the membrane, and the valve opens.

III. INTERFACE CARD - CIRCUIT DESCRIPTION

The circuit is developed in a PCB design software, and prepared with a PCB prototype milling machine.

d) Input-output surface: The microcontroller is connecting the device trough the ports seen on Fig.6. With these input-output signals are enabled to supervise the full process. The microcontroller's outputs and other processable signals found the connector named by "IN". The device's outputs are the inputs for the microcontroller, from the "OUT" named connector.

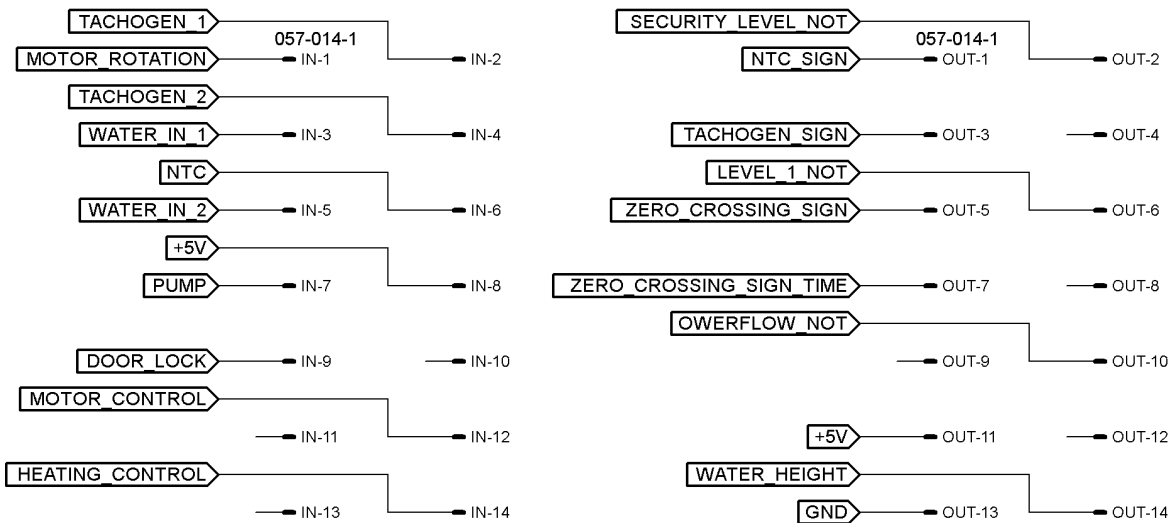

Fig. 6. All of the washing-machine's sensors as the input interface for the fitting electronic circuit.

TACHOGEN_1 and TACHOGEN_2 are the outputs of the main motor's tacho-generator's coil. NTC and +5V is for measuring temperature with a Negative Temperature Coefficient resistor. The thermistor's typical value in 20°C is 6,05kΩ, in 60°C is 1,25kΩ, and in 80°C is 620Ω. WATER_IN_1 and WATER_IN_2 are the solenoids, and there is a PUMP too. HEATING_CONTROL and MOTOR_CONTROL are the input signals for the unit, which do the phase cleavage. With MOTOR_ROTATION we can change the motor's direction of rotation. The DOOR_LOCK pin is decide when can or can not to open the door. Inside the door lock unit is a bimetallic plate, it is changing its shape when current is flowing trough and heating it up.

NTC_SIGN and WATER_LEVEL are analogue signals, they going to the microcontroller's A/D inputs. SECURITY_LEVEL_NOT is the minimal water height that is needed to starting the heating. LEVEL_1_NOT is the nor-

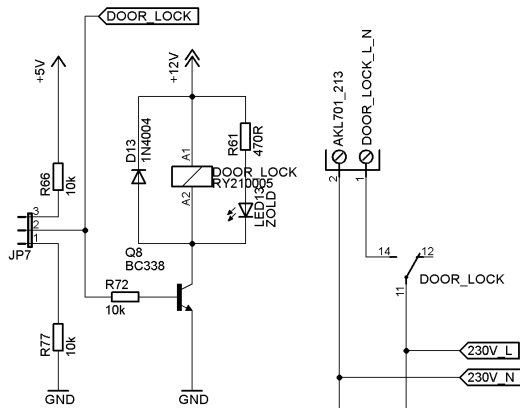

Fig. 5. A typical circuit solution for a dual state sensor polling, and relay driving.

mal amount of water when the system is working. OWERFLOW_NOT is active when there is too much water in the tank. ZERO_CROSSING_SIGN is a short impulse from the mains voltage, it is used to calculate the phase cleavage unit's starter pulse. There is a longer version of this sign named by ZERO_CROSSING_SIGN_TIME. The TACHOGEN_SIGN pin is monitoring the main motor's speed, it is although use a zero crossing finder principle, but with an other embodiment. +5V and GND provides power to the microcontroller [1].

e) Power supply: The circuit's power consumption is low, so it is sufficient to use a by-pass power supply. The anti interference filter is included in the washing machine. The protection ensures the fuse. A center-tap transformer's secondary voltage with the full-wave rectification and stabilization of the circuit is required to be 12V and 5V respectively (Fig.7). A center-tap transformers secondary voltage with the full-wave rectification and buffering is produces the 12 volts for the circuit. The BOOST stabilizer IC gives the 5 volts. The positive voltage regulator IC's voltage must always be higher than it need to be stabilized. The ceramic capacitors protect against feedback.

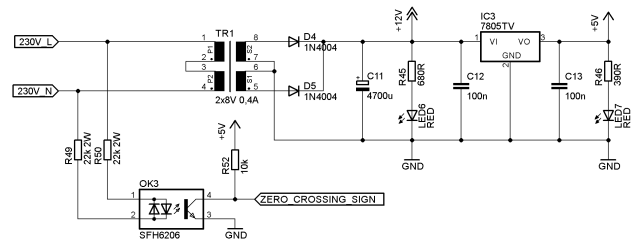

Fig. 7. Power supply unit with zero-crossing detector.

f) *Zero crossing*: Looking at Fig.7 zero crossing, there is the first part of the zero crossing circuit. The circuit is developed for the 230V mains voltage with the $\pm 10\%$ tolerance. The zero crossing value is at 90% of the half length of the sinus wave, it arises to U_z , calculated with rated voltage. (1);

$$U_z = t \cdot U_p \cdot \sin \frac{2\pi}{T} \quad (1)$$

where; U_z output voltage of opto-coupler, U_p pick value of power voltage, t the suspected time.

The SFH6206 OPTO-coupler have two, parallel, opposite direction infrared diode, so it is enabled to detect the positive and the negative half period to. This device's CRT (Current Transfer Ratio) is 34-70% between 5V collector-emitter voltage and 1mA input current. In the worst case the collector current will be $340\mu\text{A}$. The leaking current of the device is 100nA and we have got a $15\text{k}\Omega$ pull up resistor in the output. The high logic level is 4,9985 volts and the low level is 0 volts. The device's maximal collector current is 50mA, we calculated 8,3mA, so we are within the limits. The input resistors dielectric strength is guaranteed too.

g) *Relays*: The Fig.5 door lock shows the solution, how to control the electric motors and solenoids. The input signal comes from the microcontroller. The pull up or pull down resistor is optionally. The NPN transistor pulls the relay, and the relay activate the appropriate peripheral. In the schematic there is an indicator LED too, it lights when the relay is pulled on. When the relay is switched off, the relay's coil is indicates a reverse direction voltage, based on the Lenz's Law. The diode protects the circuit from the induced voltage.

h) *Speed controller*: The main-motor and heating element power control circuit is developed by according to the principle of phase angle controlling. Fig. 8 phase cleavage shows that concept. The OPTO-DIAC separates galvanically the AC voltage and the DC voltage. It is necessary for safety. The left side is working the same as we explained in the relays topic. In the right side the TRIAC is switching the sinus wave in the required time. If the TRIAC is ignited a bit after of the zero point, then almost the full energy goes trough the load. If the TRIAC is ignited in the peak of the sin, then the half energy goes trough the load. And if the TRIAC is ignited before the zero point, then only a little energy goes trough the load, the motor's rotation speed is slow or the heating element is cool. The R_{24} resistor and the C_6 capacitor protects the TRIAC by the voltage spikes caused by the inductive load.

i) *Tacho-generator*: The tachogenerator is a coil and a rotating magnet in the motor's shaft. The coil have two output wire which are floating, and connected in the input of the operational amplifier. The current of the input signal is limited by R_1 resistor, and the voltage is limited restricted by D_1 and D_2 diodes (Fig. 9). The operational amplifier's other input pin is in half power and grounded about AC terms by C_2 capacitor. The amplification is very big, so the output will jump up to the supply voltage relay fast. C_1 and D_3 gives us the output signal between 0 and 5 Volts.

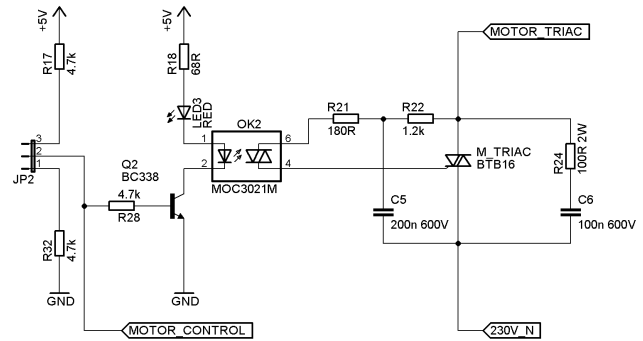

Fig. 8. Main-motor's speed-control with phase angle control circuit.

j) *Water level simulator*: In the washing machine, the water tank is a closed system. The two solenoid let the water in, the pump let the water out and the door is water-proof. The water level is enabled to measure with a pressure meter. In our system we do not wish to use water, we charging a capacitor, and the voltage level is simulating the water height. It is a greener and cost effective solution. The original device have three water level. The first is the safety level (SECURITY_LEVELTRIACNOT), it is not enabled to start the heating element when the water hight does not reaches the 55mm height, it means 3,5-4 liters. The middle level is level 1 (LEVELTRIAC_1_TRIACNOT), the water height is 80mm, it means 6-6,7 liters, it used for normal washing cycles. The last level what we need to detect is the overflow (OW-ERFLOV_TRIAC_NOT), when the water reach the 390mm height it is necessary to start the pump immediately [4]. (The water quantity is applies when the drum is without clothes.) The water heights are showing exponential growth, so we can use a simple capacitor to charge with a voltage generator. The comparators which measures the "water heights" have open collector outputs, that's why we using negated output signal names, these are logical levels. The reference voltage levels are sets by trimmer potentiometers. The WATER_HEIGHT is an analogue output shows the capacitor's current value using a following-amplifier. The control signals are the WATER_IN which active when any of the solenoids are open. The WATER_OUT signal is active when the pump is working (Fig. 10). The charging and discharging speeds are limited by the R_{16} and R_{42} resistors, and adjusted by the R_{20} and R_{41} potentiometers. The ceramic capacitors are against parasitic

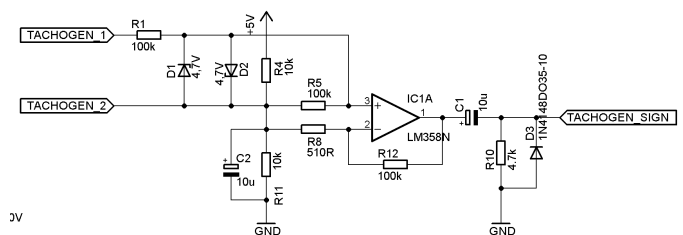

Fig. 9. Signal conditioning amplifier for main-motor's tacho-generator.

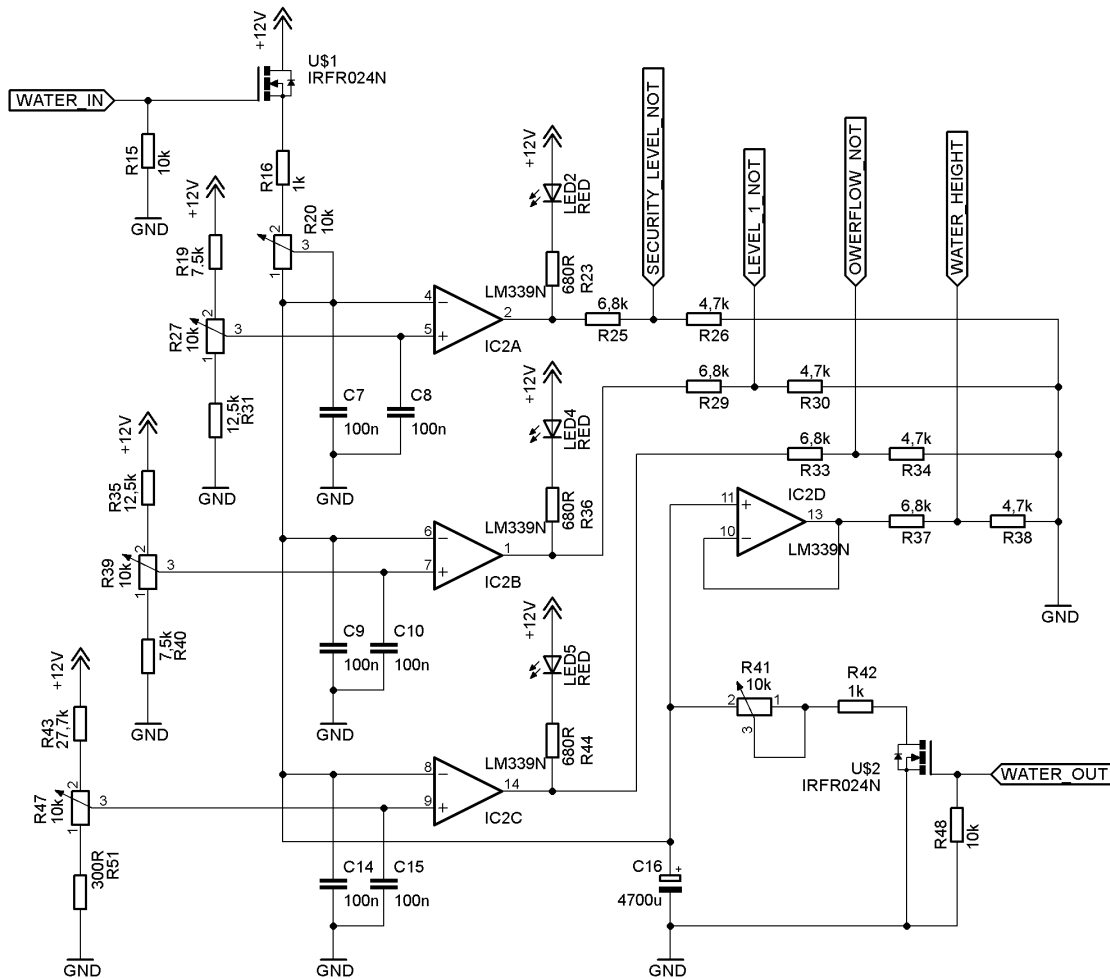

Fig. 10. Water level simulators as analog comparators, and safety logic.

oscillation caused by positive feedback [6].

IV. MAIN PROGRAMM

On the Fig. 11 is visible a flowchart of the main program. The program can be separated into three parts. The first is the pre-wash part, the second is the washing routine and the last is the rinsing. After the start the microcontroller is detecting the sensors and configuring the peripherals. The method is starting an empty drum, then filling with it up with water by the level 1 height. The motor is rotating the drum backward and forward, so all clothes will be wet. Then the program do a three minute cold wash routine. The next part is the main washing, where we use 50°C water temperature and 5 minutes washing time. This process is runs at two times, as the third phase, the rinsing. We are rinsing with clean cold water. The end of washing the clothes are spinning with high speed. The last step is some detaching rotations Fig. 12. All thermal, timing, speed, etc. parameters are optionally programmable [2][3].

V. CONCLUSION

We hope that the description of the article, is a rally inspiration for preparation of such laboratory exercises, and

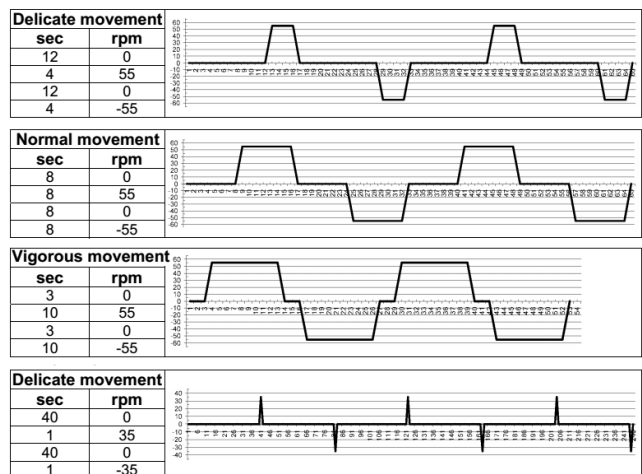

Fig. 12. Typical signal of tachogenerator at different drum functions.

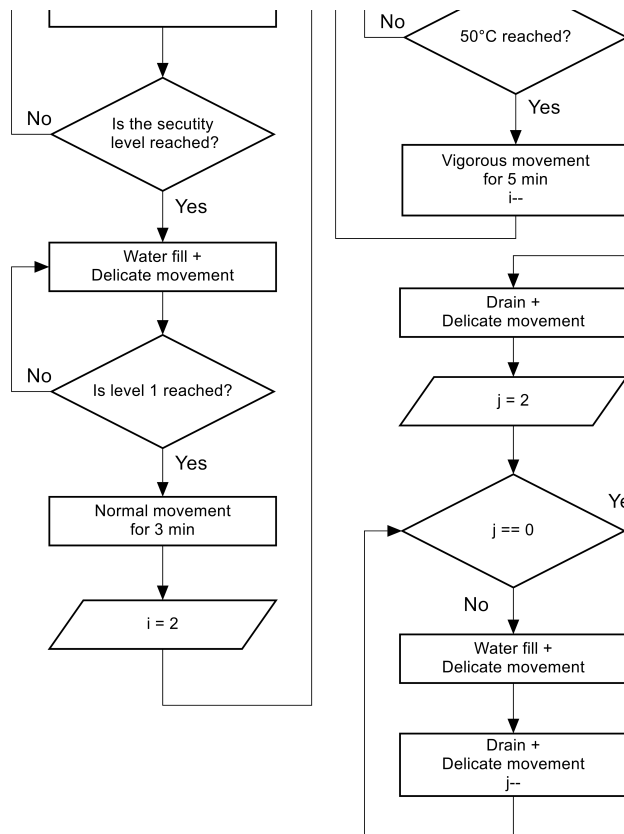

Fig. 11. Flowchart of proposed whole industrial task as a full washing-cycle.

measuring, controlling solutions.

In the future we will elaborating the function of simulate foaming watcher, and simulating pump jamming object when both solenoids are opened the "drum" fill twice as fast as one opened solenoid

REFERENCES

- [1] B. Beszedes. Implementation of a thermostat, managelable over TCP/IP network with microcontroller budai University Kand Klmn Faculty of Electrical Engineering Székesfehérvár, Hungary, January 2010.
- [2] J. Tick HPotential Application of P-Graph-Based Workflow in Logistics. Ladislav Madarsz; Jozef ivk:spects of Computational Intelligence: Theory and Applications: Revised and Selected Papers of the 15th IEEE International Conference on Intelligent Engineering Systems 2011, INES 2011. Konferencia helye, ideje: Poprad, Szlovákia, 2011.06.23-2011.06.25. Heidelberg; London; New York: Springer Verlag, 2013. pp. 293-303.(Topics in Intelligent Engineering and Informatics) ISBN:978-3-642-30667-9
- [3] J. Tick, Z. Kovacs, F. Friedler, Synthesis of Optimal Workflow Structure. JOURNAL OF UNIVERSAL COMPUTER SCIENCE (ISSN: 0948-695X) (eISSN: 0948-6968) 12: (9) pp. 1385-1392. (2006)
- [4] G. Hudoba, S. Berczi. The HUNVEYOR-project - a novel way of teaching Science and Physics HSCI2011, Proceedings of the 8th International Conference os Hands-on Science, Ljubljana, Slovenia, 2011. pp. 3-6., ISBN 978-989-95095-7-3,
- [5] Gy. Györök. Self Configuration Analog Circuit by FPAA. 4th Slovakiien–Hungarian Joint Symposium on Applied Machine Intelligence, 2006 January 20-21, Herlany, Slovakia, ISBN 963 7154 44 4 p. 34–37.
- [6] Gy. Györök. The function-controlled input for the IN CIRCUIT equipment. IEEE-INES2004 Intelligent, Engineering Systems Conference, Cluj-Napoca, Romania, 2004 September 19-21, INES 2004, ISBN 973-662-120-0, p. 443–446.
- [7] Gy. Györök, M. Makó. Self configuration Analog Circuits. XVIIth Kand conference 2006 „In memoriam Klmn Kand” Budapest Tech Kand Klmn Faculty of Electrical Engineering, 12-14 January 2006, ISBN 963 7154 426.