

PAPER • OPEN ACCESS

## Experimental Study of the Technology Parameters Affect in the Laser Welded Joints

To cite this article: Tünde Anna Kovács *et al* 2019 *IOP Conf. Ser.: Mater. Sci. Eng.* **613** 012038

View the [article online](#) for updates and enhancements.

You may also like

- [Sub-microsecond vapor plume dynamics under different keyhole penetration regimes in deep penetration laser welding](#)  
Xin Chen, Shengyong Pang, Xinyu Shao et al.
- [The effect of welding speed on mechanical and microstructural properties of 5754 Al \(AlMg<sub>2</sub>\) alloy joined by laser welding](#)  
Bekir Çevik and Behçet Gülenç
- [Effect of laser welding and laser wire filling on forming and properties of dissimilar steel welded joints](#)  
Sun Lina, Lu You and Jiang Junxiang

**PRIME**  
PACIFIC RIM MEETING  
ON ELECTROCHEMICAL  
AND SOLID STATE SCIENCE

HONOLULU, HI  
Oct 6–11, 2024

Abstract submission deadline:  
**April 12, 2024**

Learn more and submit!

**Joint Meeting of**  
The Electrochemical Society  
•  
The Electrochemical Society of Japan  
•  
Korea Electrochemical Society

# Experimental Study of the Technology Parameters Affect in the Laser Welded Joints

Tünde Anna Kovács<sup>1</sup>, Péter Pinke<sup>2</sup>, Enikő Bitay<sup>3</sup>

<sup>1,2</sup>Óbuda University, Bánki Donát Faculty of Mechanical and Safety Engineering, Department of Materials Technologies, 1081 Hungary, Budapest, Népszínház u., 8  
<sup>3</sup>Sapientia Hungarian University of Transylvania, Faculty of Technical and Human Sciences, 540485 Romania, Târgu-Mureş, Op. 9., Cp. 4

E-mail: [kovacs.tunde@bkg.uni-obuda.hu](mailto:kovacs.tunde@bkg.uni-obuda.hu)

**Abstract.** The laser welding technology is improving immediately rapidly nowadays. It has many advantages against the traditional welding technologies. The heat affected zone in case of the laser welding is very thin and the penetration of the joint is depth. This high energy technology works by a focused high energy laser light accompanied by protective gases. For the welding process well known the different laser devices (gas laser, solid-state laser, disc laser). The effect of the gases and the technological parameters are not well known yet. In this work, we wanted to find some relationship between the welding parameters and the joint mechanical properties. To find this relationship it was welded the joint by different technological parameters and the samples experimented the joint mechanical properties with different parameters and controlled by the experimental way.

## 1. Introduction

The welding technology is a rapidly developed joining technology. Laser welding is a fusion welding technology, which uses heat. The melted materials solidification prepares the joint and occurs a cohesion joint between parts during the process [1-3]. Laser technology is a special technology because the heat occurs from light. The concentrated light energy means the laser is very useful in case of many different technologies like thermal cutting, welding, engraving.

The laser welding technology process effects aren't well understood yet. The laser machining setup is the base of this technology. Between the welding fusion welding technologies, this process causes a small heat affected zone (HAZ). The quality of the welded joint depends on the welding technology parameters and the affected heat and the metal heat transfer. The key to this technology process is the knowledge of the effect of the used parameters. The precedent way the practice based results to acquire this knowledge.

The laser technology important parameters are like the welding gas (Ar, CO<sub>2</sub>, He, etc. and their mixes, and percentages), the welding speed, the focus point and the used power are also important. The used alloys (chemical composition), the sheet thickness and the joint type also influence the welded joint quality [2,4]. It can specify the optimal welding process parameters based on the practice and quality control results (destructive and nondestructive inspections).

## 2. Welding processes and Materials

In the material the laser waves effect a melted metal surrounded depth plasma canal (keyhole welding). The essential requirement is to produce and sustain the plasma canal during the keyhole welding. In case of welding processes very useful the laser welding (gas laser, solid-state laser or disc laser). The concentrated heat during the welding process melts the filler metal and the base metal and causes a very thin heat affected zone.



### 2.1. CO<sub>2</sub> laser welding

In the practice, the most applied gas laser type is the CO<sub>2</sub> laser technology. In case of this gas laser technology, the used laser material is a mix of the Carbon-dioxide, Nitrogen and Helium, and the active material is the CO<sub>2</sub> gas. In the gas volume, it works in continuous laser emission but it can work in impulse mode too. A CO<sub>2</sub> laser wavelength is  $\lambda=10,6 \mu\text{m}$ , that means the infrared area. In this way, the power can be more than 100 kW and the average emission part is 20% [5].

### 2.2. YAG laser welding

An optically pumped solid-state laser which is constructed of components held in association by a support structure which is configured to receive the components and Yttrium-Aluminium-Garnet (YAG). Nd: YAG lasers are widely used in a variety of applications [5-8].

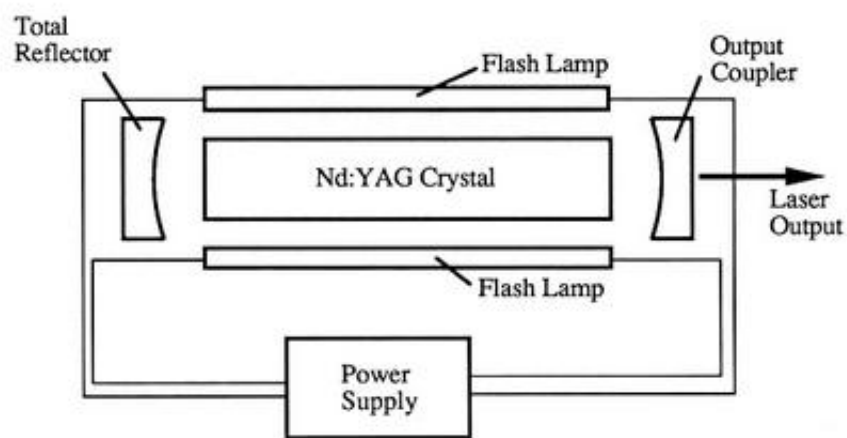

**Figure 1.** Nd: YAG laser setup [6].

### 2.3. Used materials

It was used two different steel in this study. It was joined an austenite stainless steel and low carbon steel. The chemical composition of the used steels showed in Tab.1-2.

**Table 1.** The chemical composition of the stainless steel beside irons in weight %  
steel sign: X2CrNiMoN17-11-2

C %	Si %	Mn %	Ni %	P %	S %	Cr %	Mo %	N %
0,03	1,0	2,0	10	0,035	0,015	16,5	2	0,12

In case of low carbon steel (S355JR) welding process, the preheating is not a requirement because of the low carbon equivalent (the carbon equivalent can calculate from the chemical composition) and the small samples sizes. In the case of the austenitic stainless steel, the preheating is usually forbidden and about the samples size isn't required.

The prepared joint was between two rings. The welded sample is showed in Fig. 2.

**Table 2.** The chemical composition of the low carbon steel beside irons in weight %  
steel sign: S355JR

C %	Si %	Mn %	P %	S %	N %	Cu %
0,21	0,6	1,4	0,045	0,045	0,014	0,6

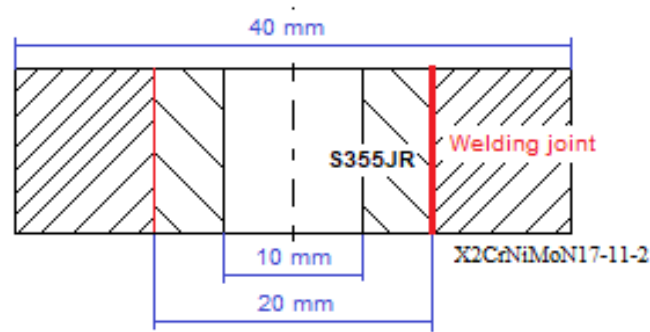

**Figure 2.** The welded sample

### 3. Experiments

In this work, it was made the welding by two different laser welding process. In case of the first group, it was weld 3 samples by CO<sub>2</sub> laser and Nd: YAG laser welding with the same parameters.

#### 3.1. CO<sub>2</sub> welding tests

These welding process parameters were: welding rate 2000 mm/min, laser power 3250 W. The used gas was the M20 signed working gas, the volume of the gas 7 l/minute, pressure 7 bar. The welded joint depth is 4 mm (shown in Fig. 3.). The joint not symmetric because it was welded two different steel with different heat transfer properties. The joint chemical composition is a mix of these different steel.

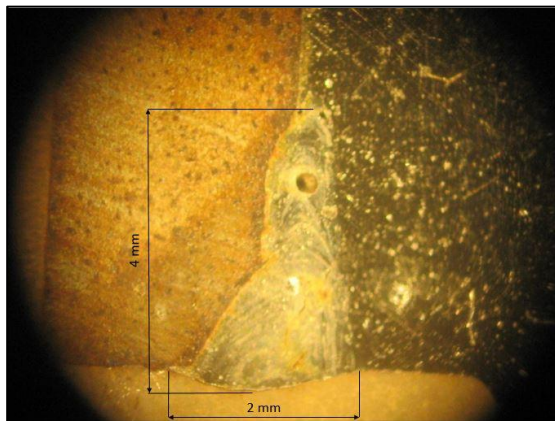

**Figure 3.** CO<sub>2</sub> laser welded joint

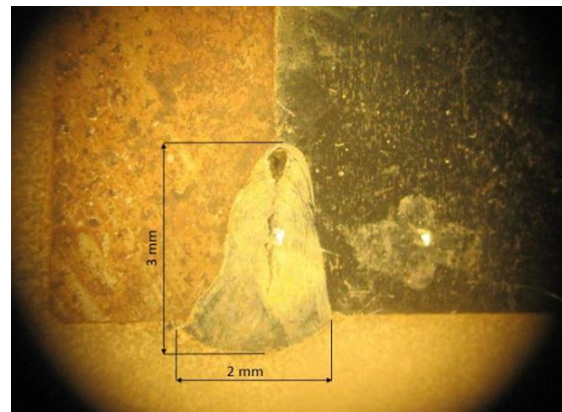

**Figure 4.** Nd:YAG laser welded joint

#### 3.2. Nd:YAG laser welding tests

The Nd: YAG solid-state welding parameters were: welding rate 390 mm/min, laser power 2700 W. The used shielding gas was CO<sub>2</sub>, volume 20 l/minute, pressure 5 bar. The joint depth was 3 mm (shows in Fig.4.). In the middle of the joint find in every tested joint a longitudinal crack.

## 4. Results and Discussion

*Mechanical properties of the experimented samples*

**Table 3.** The hardness in the tested joint and the HAZ (HV<sub>10</sub>)

State	Hardness test location		
	X2CrNiMoN17-11-2	Joint	S355JR
Original	223	-	239
CO <sub>2</sub> welded	222	354	240
Nd:YAG welded	230	382	281

The welded joint and the heat affected zone (HAZ) was tested by microscopy and hardness test ( $HV_{10}$ ). To determine the hardness in the welded joint and in the heat affected zone it was used a traditional Vickers hardness tester the applied load is 10 kg. The tests results are shown in the Tab. 3. and on the Fig. 5-6. The hardness of the steels before and after the welding process shows in the Tab.3.

In case of the welded joint and the HAZ the required hardness need to be under  $350 HV_{10}$ .

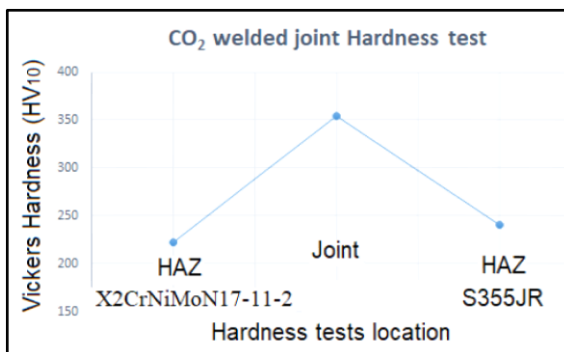

Figure 5. CO<sub>2</sub> laser welded joint hardness

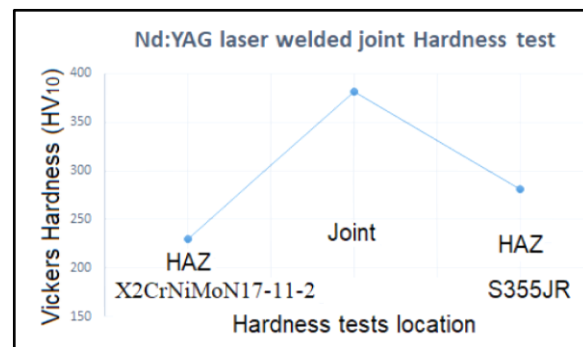

Figure 6. Nd:YAG laser welded joint hardness

## 5. Conclusion

It can conclude that the CO<sub>2</sub> laser welded joint the measured hardness showed the required results, under  $350 HV_{10}$ .

- I. In the CO<sub>2</sub> laser welded joint it wasn't found crack propagation, but in the Nd: YAG laser welded joint it was detected this failure in case of every tested sample.
- II. The hardness test results showed that in the joint was the hardness the highest. These results cause the welded joint chemical composition because of the low carbon steel and the austenitic stainless steel mixed during the fusion welding process.
- III. The joint hardness was lower in case of the CO<sub>2</sub> welded joint.
- IV. It can suggest that in the case of this samples (with the used chemical composition and geometrical properties) the followed process is the CO<sub>2</sub> laser welding besides the used technological parameters.

## Acknowledgement

We acknowledge the financial support of this work by the Hungarian State and the European Union under the EFOP-3.6.1-16-2016-00010 project.

## References

- [1] Bitay Enikő, Dobránszky János 2014 XIX. Fiatal Műszakiak Tudományos Ülésszaka – FMTÜ, EME, ISSN 2067 – 6 808 Kolozsvár 77 <http://hdl.handle.net/10598/28203>
- [2] Buza Gábor 2012 Lézersugaras technológiák I. EDUTUS [http://www.tankonyvtar.hu/en/tartalom/tamop412A/2010-0017\\_50\\_lezersugaras\\_techonologiak\\_I/index.html](http://www.tankonyvtar.hu/en/tartalom/tamop412A/2010-0017_50_lezersugaras_techonologiak_I/index.html)
- [3] T. Kovács 2018 *Procedia Manufacturing* **22** 147 <https://doi.org/10.1016/j.promfg.2018.03.023>
- [4] E Bitay, T Kulin, Zs Puskás, Gy György, J Dobránszky 2014 *Biomaterials cutting technology* 405 In: Gáti József (ed.) 27. *Welding Conference* 2014. Óbuda University, Budapest, Hungary
- [5] John H Clark, Dennis L Werth 1988 *Solid state laser*, Patent number: US 4731795 A Amoco Corporation
- [6] <http://www.aml.engineering.columbia.edu/ntm/level1/ch05/html/11c05s07.html> (10.01.2018.)
- [7] Gy Bagyinszki, E Bitay 2013 *Danger of the laser industrial engineering works* XVIII. FMTÜ, EME, Kolozsvár 51
- [8] [www.lasermarking.trumpf.com](http://www.lasermarking.trumpf.com) (15.12.2017.)