

A multisine perturbation EIS system for characterization of carbon nanotube layers

Tamás Pajkossy¹, Gábor Mészáros, Ilona Felhősi, Tamás Marek, and Lajos Nyikos

Institute of Materials and Environmental Chemistry, Research Centre for Natural Sciences, Hungarian Academy of Sciences, Magyar tudósok körútja 2, Budapest, Hungary, H-1117

This paper is dedicated to Zdravko Stoynov on the occasion of his 80th birthday, to express our high respect towards his contribution to electrochemistry, in particular to electrochemical impedance spectroscopy.

Keywords: impedance, capacitance, interface, double layer

Abstract

With the purpose of fast characterization of supercapacitors' electrode materials, an impedance measurement system has been constructed which employs multisine perturbation. The properties of this system are described.

Introduction

In the past decades much effort has been done to develop high surface area carbon electrodes with a view to use them in electrochemical capacitors (in “supercaps”, [1]). A possible candidate for high power applications is the electrode with vertically aligned carbon nanotubes (VACNT or shortly: CNT) [2]. In a project done mainly in the Fraunhofer Institute for Material and Beam Technology, IWS, Dresden, Germany, a device – actually an atmospheric pressure CVD furnace- is being developed by which a layer of CNT can be grown onto a nickel substrate („CNT-on-Ni”) in a continuous, i.e. a „roll-to-roll” process. As a quality control step, the CNT-on-Ni layer is characterized by the measurement of surface area as if it were a supercapacitor's electrode; specific capacitance were determined from measured impedance spectra.

In general, impedance spectra of supercaps look like the ones shown in Fig.1. One of the spectra is of the traditional ones with activated carbon electrodes, the other is the one with CNT-on-Ni electrodes. At low frequency both spectra are capacitive, the higher frequency parts of the spectra are characteristic to the pore structure. To obtain a good estimate of pore-structure related parameters and of surface area, it is sufficient to measure impedance spectra in the audio frequency range, and somewhat below.

For an on-line characterization – that is, on the slowly moving Ni band leaving the CVD furnace - we need (i) an appropriate electrochemical cell which can be easily attached to, or pressed to, or snapped on the metal sheet already covered by the CNT layer and (ii) an impedance measurement system which performs the measurement very fast, within seconds. The first item is under development and hence will be shortly discussed only. The second item is the subject of the present communication: the fast impedance measurement system which directly yields parameters of a simple three to five elements equivalent circuit

¹ Corresponding author. Email-address: pajkossy.tamas@ttk.mta.hu

within two to three seconds. The properties of this measurement system are demonstrated with two-electrodes symmetrical cells.

The impedance measurement and analysis

Usually impedance measurements are performed by sinusoidal perturbation of one of the quantities of potential or current and the resulting sinusoidal signals of the other quantity is related to the perturbing signal. The spectra are compiled from frequency-by-frequency measurements. The devices needed for this method are commercially available and precise, though somewhat time-consuming in particular at low frequencies. An alternative method employs steady state multi-frequency perturbation in the form of a sum of harmonics. The potential and current signals are Fourier-transformed and impedances are calculated for each frequency. It is worth to be noted that this method has been elaborated almost a half a century ago [3,4]; also employing other forms of multi-frequency perturbation like white noise [3] or pulse sequences [5] or wavelets [6]. Though multi-frequency impedance methods were sometimes used in studies of electrode kinetics [7] and of corrosion [8], these have been much scarce than those with frequency-scan, mostly because the frequency response analyzers apparently proved to be superior over the spectrum analyzers. The multi-frequency variants of EIS are much faster than the conventional one (on the expense of lower precision – for a thorough analysis see [9]) and thus can be used to track temporal changes at constant potential or when the potential is scanned. In the latter case, obviously, certain conditions must be held regarding the relation of minimum frequency and scan rate. With this method called dynamic EIS (DEIS) the advantages of CV and EIS can be coupled; for details see a recent review [10]. In the present case, the short time available was the reason for applying multifrequency voltage perturbation.

The perturbation signal contained certain odd prime number harmonics of a base frequency only; all harmonics are of equal amplitudes and of random phases. The base frequency was chosen by adhering to the sampling rate, f_s , (or sampling time, $\Delta t \equiv 1/f_s$) of the signal digitizer. In our first experiments, a „laboratory version” of the setup was developed, based on a Tektronix MSO-2014 oscilloscope, with $f_s=62.5$ kHz. Later on, to provide portability for the system, we replaced the oscilloscope with a laboratory-built USB-interfaced 12-bit analog-to-digital converter (ADC) the sampling rate of which, with almost simultaneous sampling on its two inputs was $f_s = 5$ kHz².

The fast Fourier transform (FFT) algorithm [11] requires 2^N data-point array (we employed $N=13$, ie. 8192 datapoints were sampled); to get sharp spectrum lines, the period length of the base harmonic of frequency f_0 must match the time of the 2^N data-points. The frequency limit of impedance determination is $f_s/2$, according to the Nyquist criterion. Keeping these in mind, the frequency range of the measurement is $k_{\min} \cdot f_s/2^N$ to the upper limit, $f_s/2$ where the factor $k_{\min}=11$ stands for the first used harmonic included in the perturbing signal. Hence the

² Apart portability, the idea of using the the ADC rather than the oscilloscope can be traced back to that the contribution-to-impedance of a capacitance is larger at lower frequencies, hence it is advisable to shift down the frequency range as much as possible within the allowable time frame of a spectrum measurement. The ADC's data can be read out continuously while the measurement is still running thereby much time is gained.

frequency range is about two-and-a-half orders of magnitude broad. The frequencies of the used harmonics are approximately equidistant on the logarithmic scale. Actually, with $N=13$, $f_0=0.6103$ Hz, and $f_5=5$ kHz; the signal consists of altogether 38 harmonics in the 6.71-1786 Hz frequency range. This frequency range more-or-less fits to that of the sound cards of the personal computers (PCs), therefore the audio output of the PC can be used as a function generator as follows: The perturbing signal has been generated once as an array of 2^N data points; from this array of points - simply by repeating it - a 100 seconds record-length audio-file of .wav format has been generated. This audio file is played back by an audio player program of the computer, yielding a noise-like voltage of approximately 0.3 V rms amplitude³.

Data acquisition, i.e. digitization of the two voltages proportional to the perturbation voltage and current, is performed by the ADC. Its full control and data readout is carried out by a PC via its USB interface by a program written in C++. Some parts of the data processing (conversion of the binary readout of the digitizer and the FFT) is done also by C++ subprograms called from a VBA program ("Excel macro"). This macro performs the subsequent calculations including the curve fitting (nonlinear least means squares minimization using modulus weighting [12]) the plotting, and documenting.

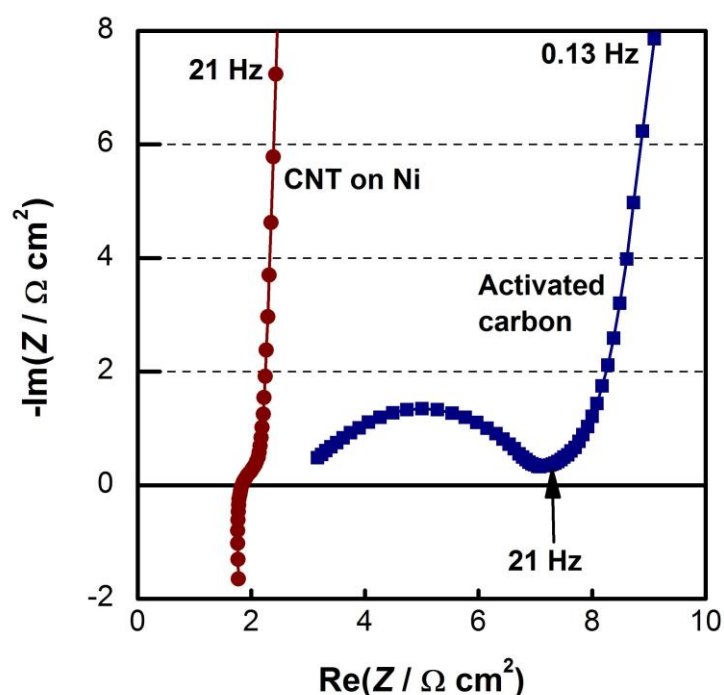

Fig.1. Complex plane impedance spectrum (circles, highest frequency 66 kHz) of a supercap, realised as two CNT-on-Ni electrodes separated by a 50 μ m paper spacer. Electrolyte: 1 M Et₄NBF₄ in acetonitrile. For comparison the impedance spectrum of a supercap made with activated carbon electrodes is also shown (squares).

³ Obviously, an arbitrary function generator would have done the same task with giving us more flexibility in setting amplitudes and frequency range. As the next step of the development, a dedicated function generator working simultaneously with a two-channel ADC is under construction.

The impedance spectra of the supercaps exhibit typical characteristics of porous electrodes. The different shapes of the spectra – like those in Fig.1 – can be attributed to the differences of the pore-size distributions. The CNT-covered electrode's spectrum corresponds to the limiting case of a pore system with uniform pores. Accordingly, its spectrum can be well fitted with the equivalent circuit model containing the impedance element of the porous layer of finite thickness [13], having a frequency dependence of $Z_{\text{pore}} \equiv k_1 \coth[k_2/\sqrt{j\omega}] / \sqrt{j\omega}$ where k_1 and k_2 are constants, ω is the angular frequency, and j is the imaginary unit. However, replacing this element by a serial W-C circuit (W is a pseudo-Warburg element and C represents the double layer capacitance of the complete surface) yields just as good fits as with Z_{pore} . The complete equivalent circuit is usually an R-W-C one, where the R resistance represents the internal resistance of the supercap electrode. In addition, at the high frequency end an inductive term also appears, which is of instrumental origin; it is easy to correct its effect, and it is irrelevant in the present context. We note that the spectrum of the activated carbon-covered electrode in Fig.1. represents another limiting case of the pore systems: when the micropores' orifices are within macropores. Impedance spectra of electrodes of such complicated geometries can be modelled by a recent theory [14].

The measurement time plus data processing time – including FFTs, impedance calculations and curve fitting to extract the capacitance and Warburg parameter – is about two seconds; measurement accuracy is sufficient to the actual purpose. The whole measurement and the subsequent analysis is carried out upon a single mouseclick.

The cell and electronics

The basic idea is that there is an electrochemical cell mounted just above the slowly moving Ni sheet - close to the edge of the sheet - in such a way that it can be pressed against the sheet and after the two-seconds measurement it can be lifted up. The cell comprises parallel layers of metal electrodes and separators: in up-to-down direction a metal disk as the counter electrode, a separator, a stainless steel mesh serving as a quasi-reference electrode, and finally a separator as the terminating element. These four layers are disks of 9 mm diameter, surrounded by, and held together by a silicon tube acting as sealing ring. Measurement is done in such a way that the cell is lowered, and the second separator is pressed against the Ni sheet. All parts of the cell must be kept wet by the electrolyte, which is slowly injected in the interelectrode space from an electrolyte reservoir. The whole cell is built into an Al cylinder serving as a Faraday cage.

The electronics belonging to the cell is simple and self-explanatory (Fig.2). Since the working electrode, the Ni sheet is in metallic contact with various parts of the furnace, the working electrode is grounded. Hence current is to be measured in the counter electrode's circuit, as a voltage across the $R_m = 10$ ohm resistor. The measurement is done at open circuit potential, thus there is no need to apply a potentiostatic feedback. The perturbation from DAC is attenuated to 10 mV amplitude by an input amplifier. The two instrumentation amplifiers are designed to be very similar to each other, they are constructed using Texas Instruments TL 082C operational amplifiers. Their AC and DC amplifications are 100 and 1, respectively.

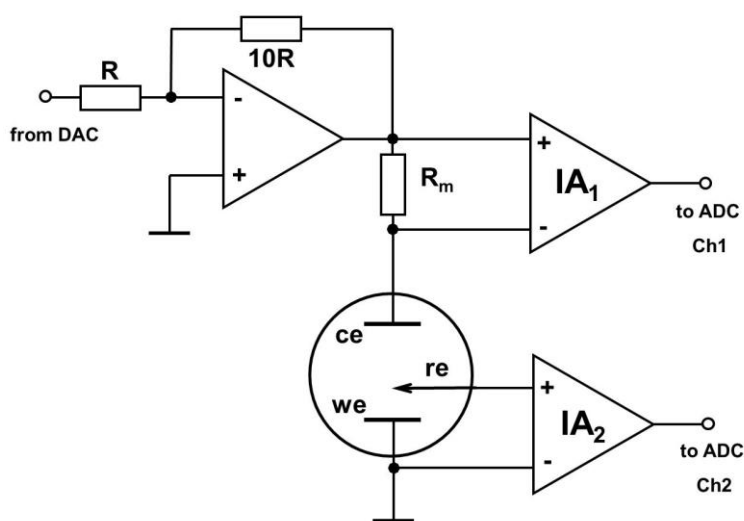

Fig. 2. Connection scheme of the cell, without the DAC and the two-inputs ADC. Note that the two instrumental amplifiers (the IAs) are of identical characteristics. **ce**, **re**, and **we** stand for the counter, reference and working electrodes, respectively; for the two-electrodes cell **ce** and **re** are shorted.

The three-electrodes cell is still under development; for testing the impedance setup (electronics of Fig.1, the digitizers and the programs) a two-electrodes simplified version is used: this comprises two stainless-steel disks of 8 mm diameter within a plastic cylinder. The „supercap” is a sandwich of two electrode sheets (disks of 7 mm diameter) separated by two sheets of 25 μm thickness ethyl-cellulose sheets (Nippon Kodoshi Corp.), wetted by the electrolyte and pressed together by the stainless steel disks by a force of 75N. In the audio-frequency range the capacitive interfacial impedance of the CNT-on-Ni is as low as 1-10 $\text{ohm}\cdot\text{cm}^2$, hence solution resistance must be also small - i.e. thin separators and high conductivity electrolyte are to be used (this latter is 1-ethyl-3-methyl-imidazolium-tetrafluoroborate (EMImBF_4) in acetonitrile, 34% (w/w), with about 45mS/cm specific conductivity at room temperature).

The presence of water and oxygen – as impurities in the organic electrolyte – affects somewhat the low frequency impedances; a parallel charge transfer resistance appears in the equivalent circuit. However, it does not affect the interfacial capacitance, in addition its effect is negligible in the frequency range of the multisine measurement. Therefore, the experiment can be done in the ambient atmosphere.

Results

The accuracy of the multisine setup was tested by comparing the obtained impedance spectra with those obtained with a Solartron impedance measurement setup (1286 potentiostat +1250 frequency response analyzer); the results are shown in Fig.3. The first is a test with a dummy cell whose impedance is similar to those of supercap cells in the audio-frequency range (a 7 ohm + nominally 4700 μF electrolytic condenser serial RC). Apart the

couple of outlier points, the spectra measured with the two setups are practically the same (Fig.3a). Fitting the parameters of a serial RC circuit to the spectra within the 5Hz-2kHz frequency yield fairly good fits (the fitting residuals are within the 1% absolute value and 1 degree margins, see Fig.3c); the fitted values of capacitance are 5.4 mF (for the Solartron setup data) and 5.1 mF (for the portable multisine setup data). That is, the multisine setup yields approximately the same capacitance (in two seconds) as the precise Solartron setup (in about one minute).

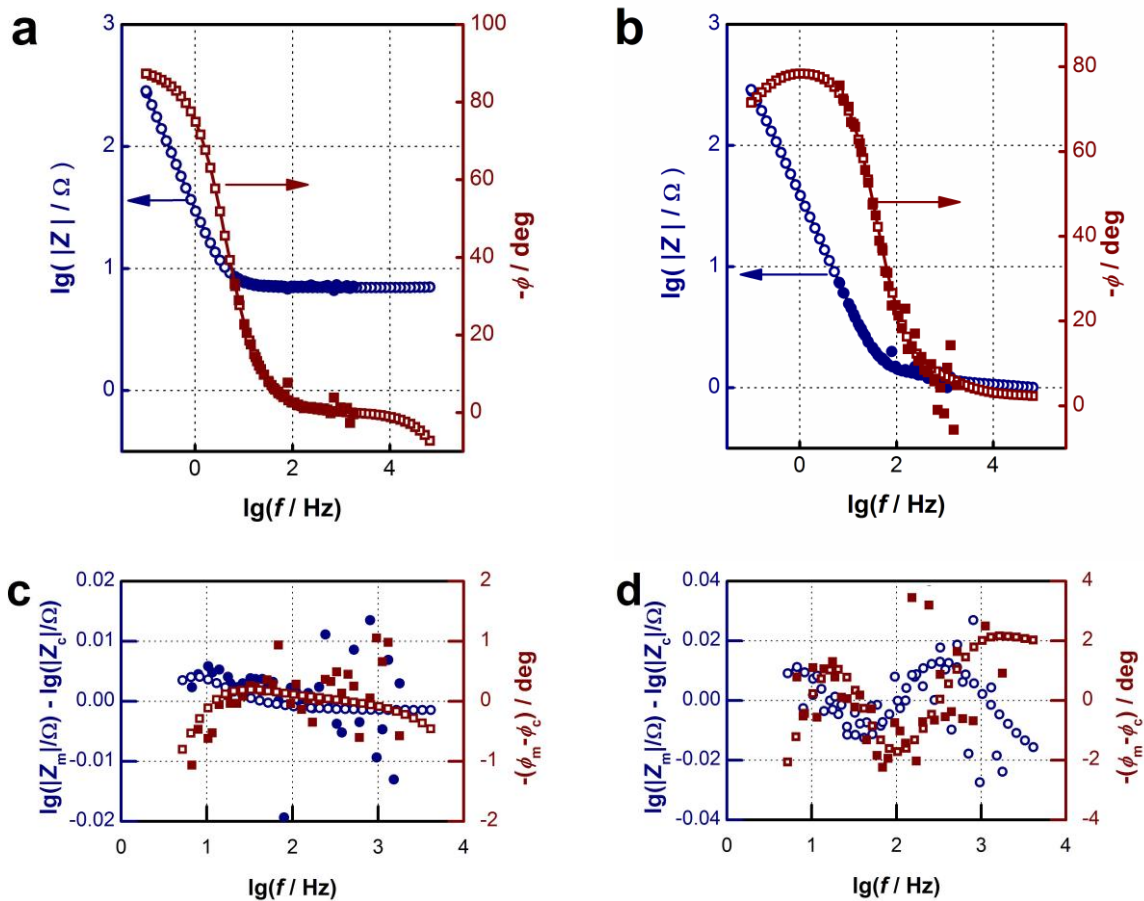

Fig.3: Impedance spectra of (a) a serial-RC dummy cell (7 ohm+4700 μF) and (b) of a CNT-on-Ni supercap (see the text), measured with a Solartron 1250+1286 setup (open symbols) and with the setup of multisine perturbation (full symbols). (c) and (d) are the fitting residuals for the two spectra. Circles and squares are magnitudes and phase angles, respectively, on all figures.

The other test was performed on a “real supercapacitor cell”, that is, with CNT covered Ni sheets electrodes. The impedance spectra are shown in Fig.3b. Just as in the case of the dummy cell, disregarding the noise around 1 kHz, the spectra measured with the two setups are practically the same. Fitting the parameters of a serial RWC circuit to the spectra within the 5Hz-2kHz frequency range resulted in sufficiently good fits (the fitting residuals are within the 2% absolute value and 2 degrees margins, see Fig.3d); the fitted capacitance values are 23.6 mF/cm^2 (for the Solartron setup data) and 21.6 mF/cm^2 (for the multisine setup data). The difference is around 10% – which is still an acceptable error limit for the given purpose.

Summary

We have constructed a simple instrument (for the simplest, inexpensive version the required components are a two-channel ADC, some operational/instrumentation amplifiers, and a PC with appropriate programs) to measure and analyze audio-frequency impedance spectra in a short time (seconds) following a single mouseclick. Due to the use of the multi-sine perturbing signal, the measurement system is fast – on the expense of accuracy. However, its accuracy might be sufficient for certain purposes, like in the present case of characterizing CNT layers produced in a continuous process.

Acknowledgements

The atmospheric pressure CVD process line was developed by Benjamin Schumm, Althues Holger and Stefan Kaskel at the Fraunhofer Institute for Material and Beam Technology, IWS, Dresden, Germany. Financial assistance of the PLIANT (Process Line Implementation for Applied Surface Nanotechnologies) FP7 project, and of the National Research, Technology and Innovation Office of the Hungarian government through the project OTKA-K-112034 is acknowledged.

References

- 1 B.E. Conway: Electrochemical Supercapacitors: Scientific Fundamentals and Technological Applications, Springer, 1999
- 2 S. Dörfler, I. Felhösi, T. Marek, S. Thieme, H. Althues, L. Nyikos, S. Kaskel: High power supercap electrodes based on vertical aligned CNTs on aluminum, *J. Power Sources* **227** (2013) 218
- 3 S.C. Creason, D.E. Smith: Fourier transform Faradaic admittance measurements: I. Demonstration of the applicability of random and pseudo-random noise as applied potential signals, *J. Electroanal. Chem. Interf. Electrochem.* **36** (1972) A1
- 4 G. Blanc, I. Epelboin, C. Gabrielli, M. Keddam: Measurement of the electrode impedance in a wide frequency range using a pseudo-random noise, *Electrochim. Acta* **20** (1975) 599
- 5 L. Pospíšil, N. Fanelli: Application of the fast Walsh-Hadamard transform and the fast Haar transform for electrochemical impedance measurements based on a periodic square-wave perturbation signal derived from Walsh-functions, *J. Electroanal. Chem.* **222** (1987) 367
- 6 G.A. Ragoisha, A.S. Bondarenko: Potentiodynamic electrochemical impedance spectroscopy, *Electrochim. Acta* **50** (2005) 1553
- 7 L. Pospíšil, M. Štefl: The application of microprocessors in electrochemistry, *Collect. Czech. Chem. Commun.* **48** (1983) 1241
- 8 L. Nyikos, T. Pajkossy: Electrochemical impedance measurements using Fourier transform (Elektrokémiai impedanciámérés Fourier transzformációval), *Magyar Kémikusok Lapja* **XL** (1986) 550 (in Hungarian)
- 9 C. Gabrielli, F. Huet, M. Keddam, J.F. Lizee: Measurement time versus accuracy trade-off analyzed for electrochemical impedance measurements by means of sine, white noise and step signals, *J. Electroanal. Chem.* **138** (1982) 201

- 10 A.S. Bandarenka: Exploring the interfaces between metal electrodes and aqueous electrolytes with electrochemical impedance spectroscopy, *Analyst* **138** (2013), 5540
- 11 J.W. Cooley, J.W. Tukey, An algorithm for the machine calculation of complex Fourier series, *Math. Comp.* **19** (1965) 297
- 12 B.A. Boukamp: A Nonlinear Least Squares Fit procedure for analysis of immittance data of electrochemical systems, *Solid St. Ionics* **20** (1986) 31
- 13 R. de Levie, Electrochemical response of porous and rough electrodes, in: P. Delahay and C.W. Tobias, (Eds.), *Advances in Electrochemistry and Electrochemical Engineering*, Vol. 6, Wiley-Interscience, New York, 1967, 329
- 14 J. Huang, J. Zhang: Theory of Impedance Response of Porous Electrodes: Simplifications, Inhomogeneities, Non-Stationarities and Applications. *J. Electrochem. Soc.* **163** (2016) A1983