

A practical manual for Vissim COM programming in Matlab

3rd edition for Vissim version 9 and 10

Tamás Tettamanti, Márton Tamás Horváth

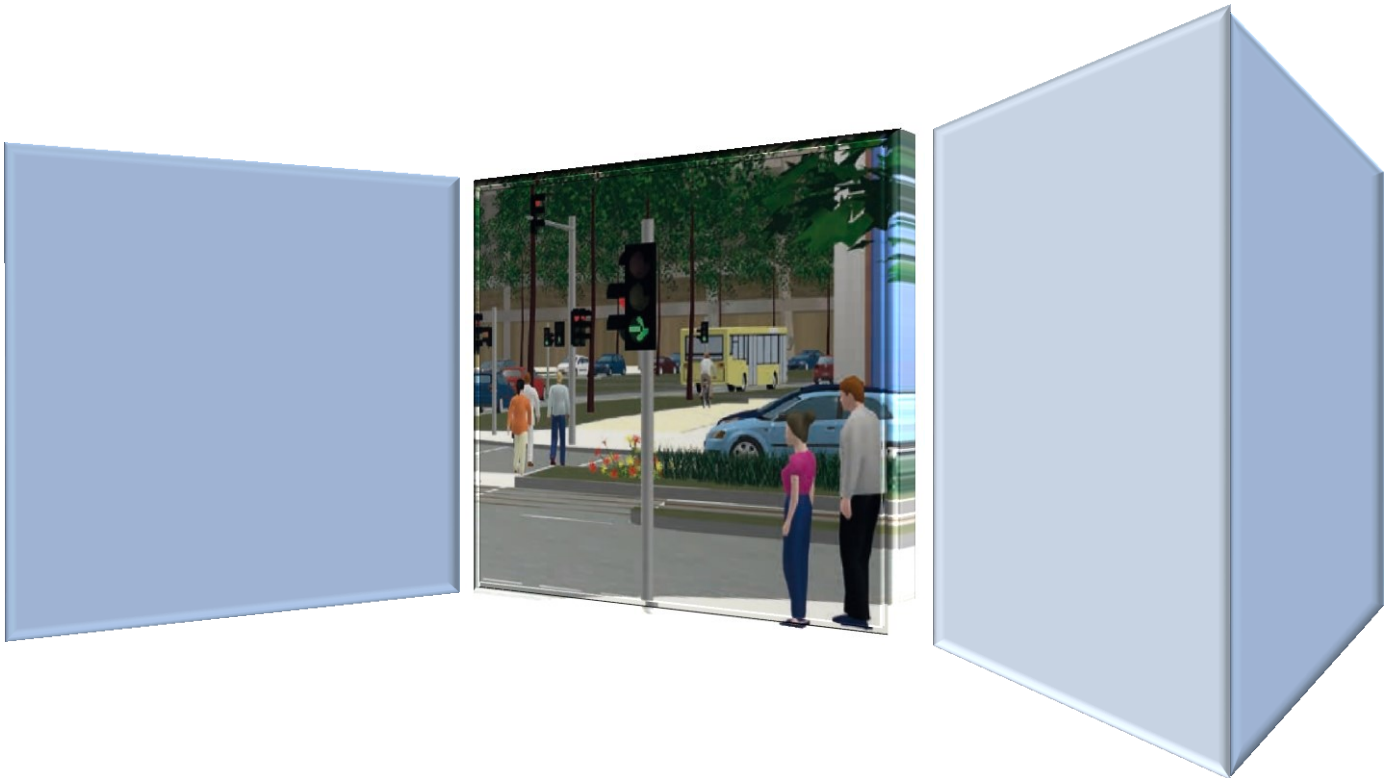

Budapest University of Technology and Economics
Dept. for Control of Transportation and Vehicle Systems
www.traffic.bme.hu

2018

1. Vissim traffic simulation via COM interface programming

1.1. The purpose of Vissim-COM programming

Vissim is a microscopic road traffic simulator based on the individual behavior of vehicles. The goal of the microscopic modeling approach is the accurate description of the traffic dynamics. Thus, the simulated traffic network may be analyzed in detail. The simulator uses the so-called psycho-physical driver behavior model developed originally by Wiedemann (1974). Vissim is widely used for diverse problems by traffic engineers in practice as well as by researchers for developments related to road traffic. Vissim offers a user friendly graphical interface (GUI) through of which one can design the geometry of any type of road networks and set up simulations in a simple way. However, for several problems the GUI is not satisfying. This is the case, for example, when the user aims to access and manipulate Vissim objects during the simulation dynamically. For this end, an additional interface is offered based on the COM which is a technology to enable interprocess communication between software (Box, 1998). The Vissim COM interface defines a hierarchical model in which the functions and parameters of the simulator originally provided by the GUI can be manipulated by programming. It can be programmed in any type of languages which is able to handle COM objects (e.g. C++, Visual Basic, Java, etc.). Through Vissim COM the user is able to manipulate the attributes of most of the internal objects dynamically.

1.2. The basic steps of Vissim-COM programming

The following steps formulate a general synthesis for the realization of any adaptive control logic through Vissim-COM interface:

1. One generates the overall traffic network through the Vissim GUI (geometry, signal heads, detectors, vehicle inputs, etc.).
2. After choosing a programming language which allows COM interface programming, one creates the COM Client.
3. Programming of the simulation via Vissim COM with specific commands, e.g.
 - simulation setting (multiple and automated runs),
 - vehicle behavior,
 - evaluation during simulation run (online),
 - traffic-responsive signal control logic.
4. Simulation running form COM program.

To understand the Vissim-COM concept, see the figure below which depicts a part of the Vissim-COM object model. The Vissim-COM is based on a strict object hierarchy with two kinds of object types:

- collections (array, list): store individual objects, references to the objects; the collection names in the Vissim-COM object model are always in plural, e.g. 'Links'. The interface for this object is the 'ILinks' interface. References to the objects can be accessed via the 'ILinkCollection' interface.
- containers: store a single object, the objects themselves; the container names are always in singular, e.g. 'Link'. The interface for this object is the 'ILink' interface. The objects themselves can be accessed via the 'ILinkContainer' interface.

‘This distinction between containers and collections is needed because objects are linked to one another. Adding new objects or deleting objects is only possible in the container.’ (PTV, 2017)

The letter ‘I’ always represents the interface for the object.

The objects are in a hierarchical structure of which the head is the main Vissim object. IVissim is the interface representing the Vissim object. Only one main object can be defined and all other objects belong to the main object.

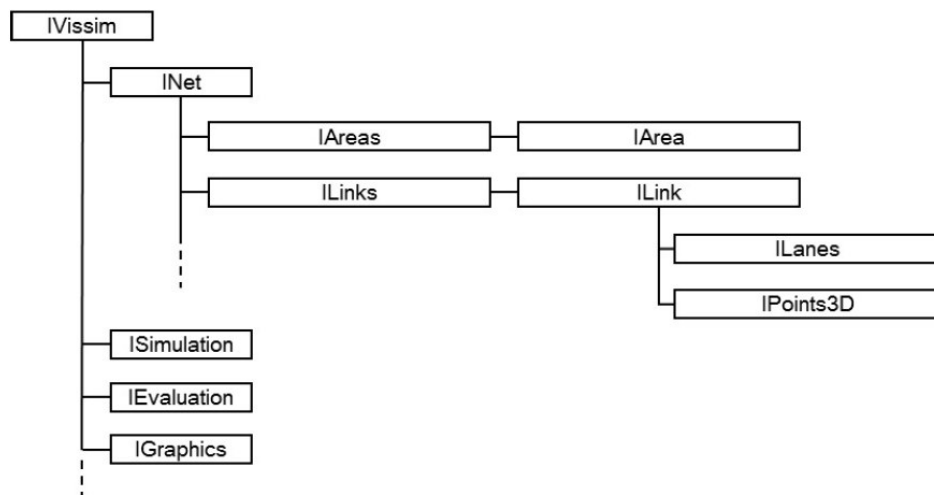

1. The Vissim-COM object hierarchy (PTV, 2017)

The full Vissim-COM object hierarchy model is described in the Online Help of Vissim that can be accessed via the Vissim GUI. Click on Help\Online Help...\Vissim-COM\Objects. To access the IVissim interface, representing the Vissim object, click on IVissim (see fig. 2). Under the Public Properties headline you can see five properties that return object instances. These are Evaluation, Graphics, Net, Presentation and Simulation. Thus IEvaluation, IGraphics, INet, IPresentation and ISimulation interfaces, representing the Evaluation, Graphics, Net, Presentation and Simulation objects, are available.

2. Accessing the objects of Vissim (Vissim online help)

To understand the object model, consider the following example, which represents the access to a given road link:

1. Below the main interface 'IVissim' (representing the 'Vissim' object, see fig. 1) you can find the 'INet' interface (representing the 'Net' object), which compasses all network functionalities.
2. Collections are situated below object 'Net' (of which the interface is 'INet').
3. Collection 'Links' (of which the interface is 'ILinkContainer') contains the references to the links of the network (previously defined via Vissim GUI). 'Links' is a Public Property of 'INet'. The Link objects themselves are contained in the Links object for which 'ILinkCollection' is the interface (The same is valid for e.g. 'Areas' and 'IAreaCollection').
4. To access a given 'Link' object, one needs to define 'Vissim', 'Net', and 'Links' objects. 'ILinkContainer' (and containers generally) has a Public Property called 'ItemByKey' that makes it possible to access the 'ILink' interface for a specific Link object
5. After accessing the given 'Link', one may apply Vissim-COM methods (e.g. 'RecalculateSpline'), as well as query or set attributes (e.g. 'NAME').

This example is presented now by Visual Basic Script language. This practically shows the access to Link 10 (after the apostrophe character you can read comments):

Set vis = CreateObject('Vissim.Vissim')	'define Vissim main object
Set vnet = vis.Net	'define Net object
vis.LoadNet('D:\Example\test.inpx')	'Load the traffic network
Set links = vnet.Links	'define Links collection
Set link_10 = links.ItemByKey(10)	'Query Link 10 as an object

1.3. How to use Matlab for Vissim-COM programming?

In the following chapters the Vissim-COM programming is introduced by using Matlab Script language. For this the Vissim-COM interface manual (PTV, 2017) used to provide a detailed help until Vissim version 5 but since then the official offline help is significantly less detailed. Instead of that you can use the online help (in the Vissim GUI click on Help\Online Help...) or the official examples provided for Vissim. Although the examples of this official manual are basically written in Visual Basic, the document also provides a short help so that we can transform the scripts into other programming languages (therefore into Matlab environment) as well. The principle of COM programming is the same written in any language.

One of the main advantages of using Matlab is the simplicity of the Matlab Script language. Another very important aspect is that Matlab (as a mathematical software package for practical purposes) has a lot of built-in functions. For example, optimization tasks can be solved with the help of simple Matlab commands, statistical functions can be called freely or simple matrix usage can be achieved. With the functions provided by Matlab a lot of time and energy can be spared compared to other programming languages. Therefore, if you are programming the Vissim traffic simulator via COM, but you also want to perform special operations (e.g. optimization), it is highly recommended to choose the Matlab Script as the basic language for programming Vissim-COM.

Important technical information is that before creating a Vissim-COM program, you must register the Vissim as a COM-server in your operating system (so that other applications can access Vissim-COM objects). You can do the registration after the installation of Vissim by clicking on menu 'Help/Register COM server'.

2. Creating Vissim-COM server in Matlab

User may create a script file (extension '.m') in Matlab with the 'File/New/Script' menu or with the white paper icon located in the toolbar (see figure below).

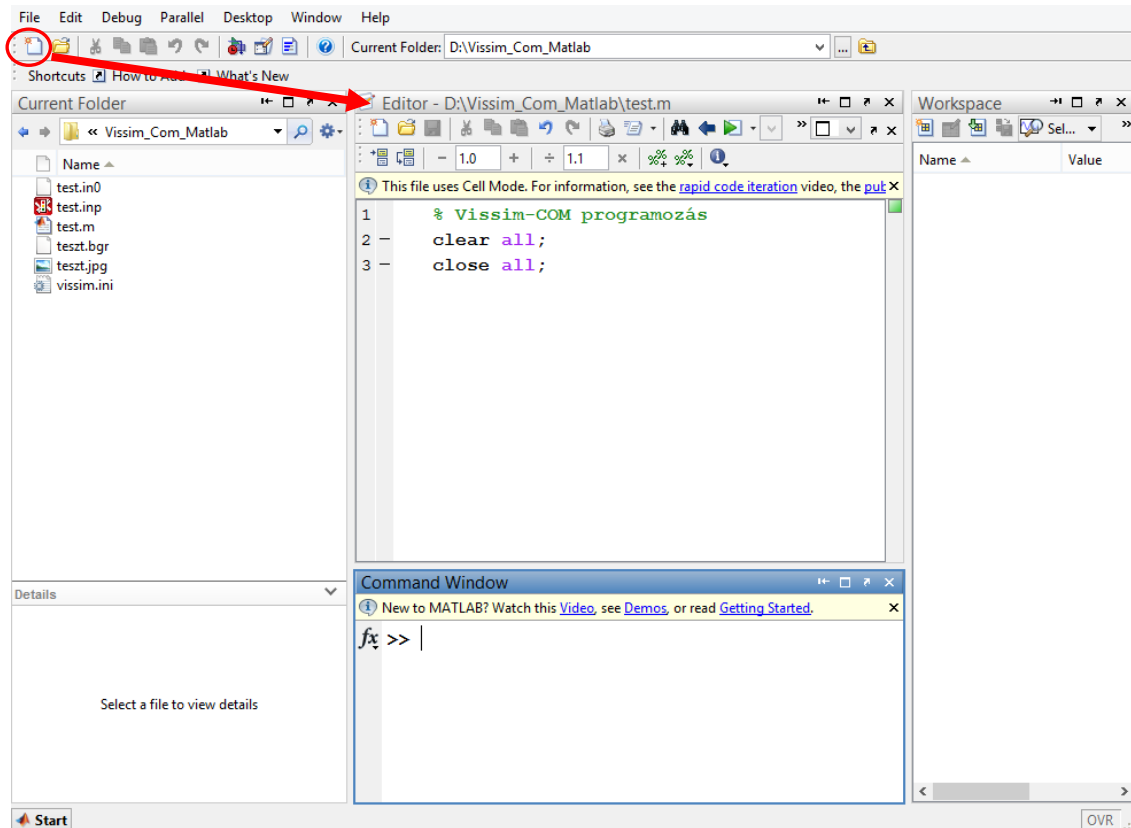

3. Creating Matlab Script file (extension '.m')

In the Matlab Script code you can write comments after the % sign.

It is useful to start '.m' files with two basic commands:

`clear all;`

`close all;`

The first deletes the contents of the Matlab workspace, i.e. the currently used variables and their values. Delete is very useful to avoid errors, e.g. the remained values of the variables in the previous executing may cause confusion. The second command closes all of the opened Matlab windows (e.g. diagrams) in one step.

Creating a new COM server (other name ActiveX) is possible with the use of the Matlab command 'actxserver':

`vis=actxserver('VISSIM.vissim.900')`

For detailed information about a Matlab command use the Command Window and write the 'help' before the command e.g.

`help actxserver`

3. Vissim-COM methods

Object methods created via the Vissim-COM server are also accessible in the Command Window. The list of the objects can be found in the Vissim-COM Interface Manual (PTV, 2017). We can access the method list of each object if we type the object's name and the 'methods' command with a dot between them into the Command Window:

`{Vissim-COM object name}.methods`

The method above can only be used if the object written between the curly braces was defined beforehand. For example take a look at the following figure, which can be used for the object 'vis' (main object predefined in the previous chapter), and shows the list of all methods.

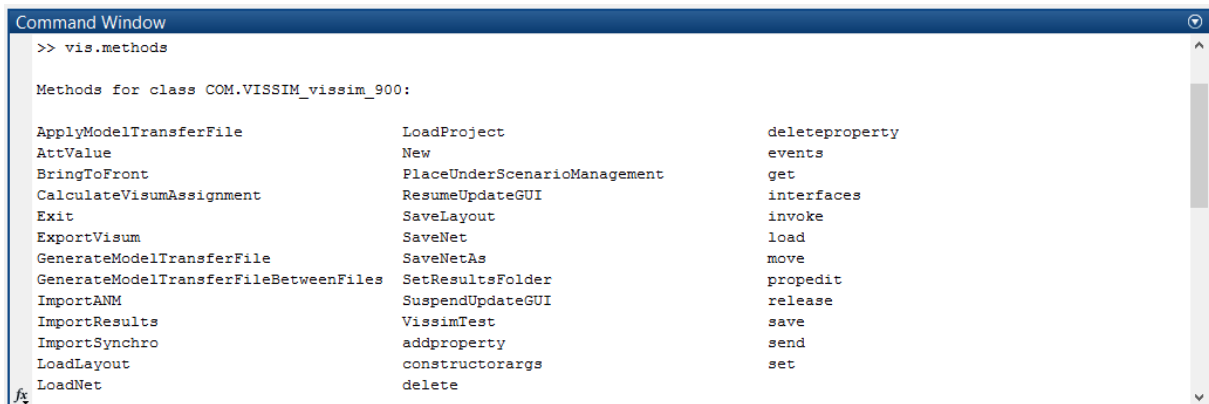

```
Command Window
>> vis.methods

Methods for class COM.VISSIM_vissim_900:

ApplyModelTransferFile      LoadProject                  deleteproperty
AttValue                    New                          events
BringToFront                PlaceUnderScenarioManagement get
CalculateVisumAssignment    ResumeUpdateGUI             interfaces
Exit                        SaveLayout                  invoke
ExportVisum                 SaveNet                      load
GenerateModelTransferFile   SaveNetAs                   move
GenerateModelTransferFileBetweenFiles SetResultsFolder            propedit
ImportANM                   SuspendUpdateGUI           release
ImportResults               VissimTest                  save
ImportSynchro               addproperty                 send
LoadLayout                  constructorargs             set
LoadNet                     delete
```

4. Getting the method list of the object 'vis' in Matlab

From the method list above the 'invoke' is shown below as an example.

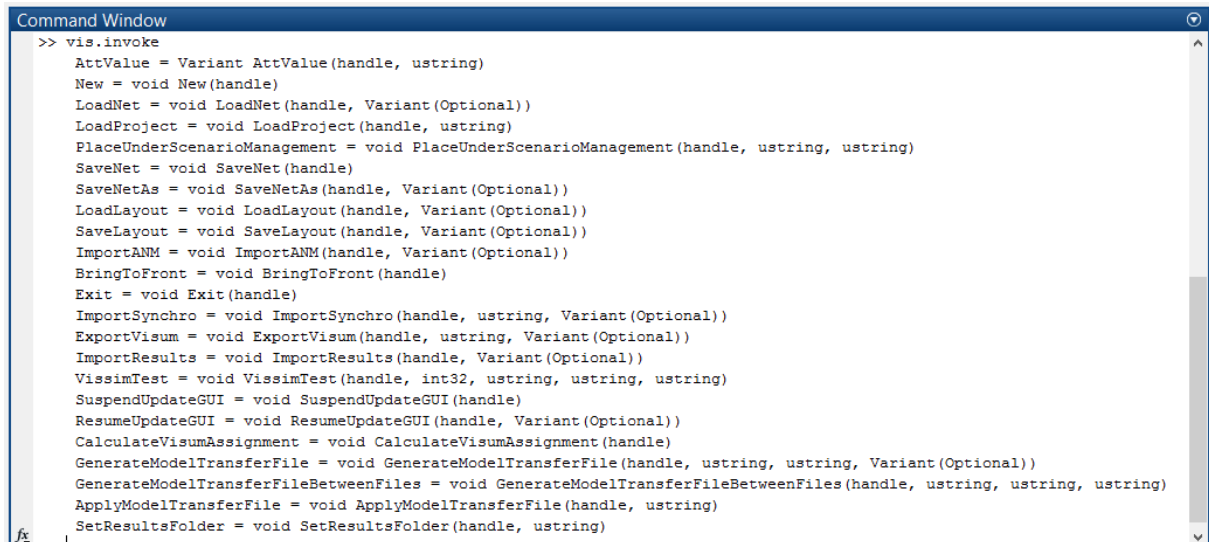

```
Command Window
>> vis.invoke
AttValue = Variant AttValue(handle, ustring)
New = void New(handle)
LoadNet = void LoadNet(handle, Variant(Optional))
LoadProject = void LoadProject(handle, ustring)
PlaceUnderScenarioManagement = void PlaceUnderScenarioManagement(handle, ustring, ustring)
SaveNet = void SaveNet(handle)
SaveNetAs = void SaveNetAs(handle, Variant(Optional))
LoadLayout = void LoadLayout(handle, Variant(Optional))
SaveLayout = void SaveLayout(handle, Variant(Optional))
ImportANM = void ImportANM(handle, Variant(Optional))
BringToFront = void BringToFront(handle)
Exit = void Exit(handle)
ImportSynchro = void ImportSynchro(handle, ustring, Variant(Optional))
ExportVisum = void ExportVisum(handle, ustring, Variant(Optional))
ImportResults = void ImportResults(handle, Variant(Optional))
VissimTest = void VissimTest(handle, int32, ustring, ustring, ustring)
SuspendUpdateGUI = void SuspendUpdateGUI(handle)
ResumeUpdateGUI = void ResumeUpdateGUI(handle, Variant(Optional))
CalculateVisumAssignment = void CalculateVisumAssignment(handle)
GenerateModelTransferFile = void GenerateModelTransferFile(handle, ustring, ustring, Variant(Optional))
GenerateModelTransferFileBetweenFiles = void GenerateModelTransferFileBetweenFiles(handle, ustring, ustring)
ApplyModelTransferFile = void ApplyModelTransferFile(handle, ustring)
SetResultsFolder = void SetResultsFolder(handle, ustring)
```

5. The answer of Matlab Command Window to the 'invoke' command of a Vissim-COM object

As it can be seen, the list shows the available methods with the return value types and arguments. The 'variant' is a variable type which involves several types. 'void' means that the method does not have any return values.

If you find this manual useful, please, cite this paper: <https://doi.org/10.3311/pp.ci.2012-1.05>

Similarly, the methods concerning any other Vissim-COM object can be listed analogously.

Another useful Matlab command is applicable to reveal the properties of an object. This can be done by 'fields' command:

```
{Vissim-COM object name}.fields
```

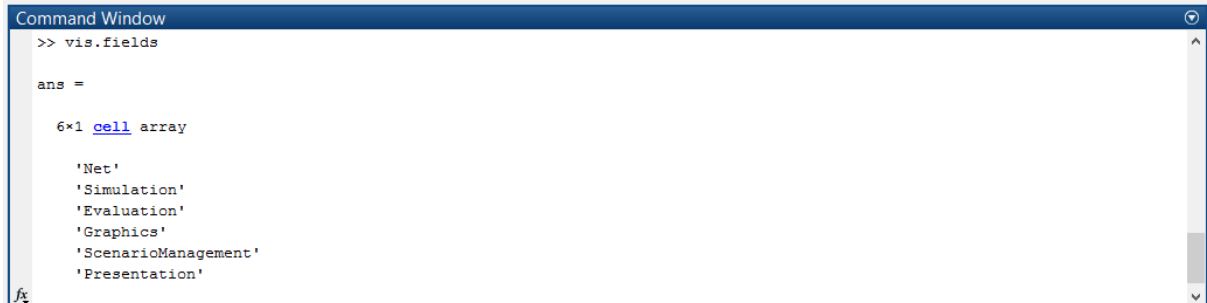

```
Command Window
>> vis.fields

ans =

6x1 cell array

'Net'
'Simulation'
'Evaluation'
'Graphics'
'ScenarioManagement'
'Presentation'
```

6. The answer of Matlab Command Window to the 'fields' command of a Vissim-COM object

4. Loading of Vissim network

In case of Vissim-COM programming you must create the simulation network and its elements on the graphic interface of the Vissim. You will get a project file that has an .inpx extension, and a 'Layout' file with .layx extension. Then, you can infuse them from the COM program with 'LoadNet' and 'LoadLayout' methods. While you use them you can give them to the Vissim files with their direct access path that shows the destination of the files with the letter of the driver and name of the containing folders, i.e.

```
vis.LoadNet('D:\Vissim_Com_Matlab\test.inpx');
```

```
vis.LoadLayout('D:\Vissim_Com_Matlab\test.layx');
```

But there is also a possibility to give a relative access path, and that is the better solution. You should only use the 'pwd' command from Matlab, and it shows the access path of the current folder (see figure below).

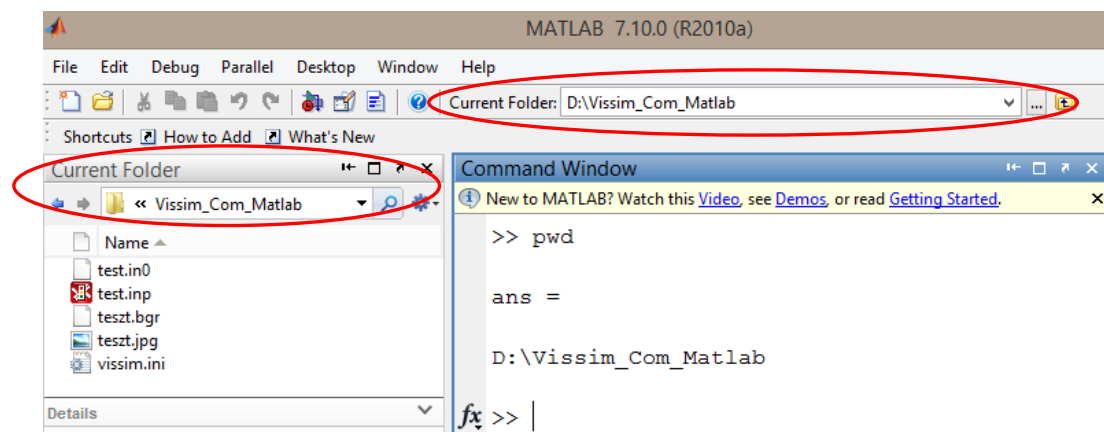

7. Using the 'pwd' command in Matlab command line

You can load the network with relative access path as follows:

```
access_path=pwd;
```

```
vis.LoadNet([access_path '\test.inpx']);
```

```
vis.LoadLayout([access_path '\test.layx']);
```

Using the relative access path is very useful if you wish to run the Vissim project on different computers. You should only copy the project folder onto the current computer and open the Matlab Script file from there. Thus, there is no need to refresh the whole path of the Vissim project folder before running the code.

5. General simulation adjustments in Vissim-COM program

Hereinafter we introduce the setting of object properties and attributes. We describe the simulation adjustments as a specific example, but of course the method is the same with other objects as well.

For simulation settings first you must define the 'ISimulation' object that can be found under the main object in the hierarchy-model of Vissim-COM (see below). We can do that via the previously defined main object called 'vis':

`sim=vis.Simulation;`

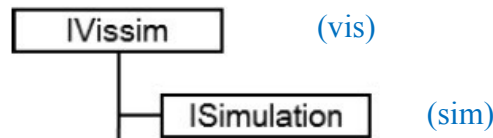

8. 'Simulation' is below the main object 'Vissim' in hierarchy; between the round brackets you can read the name of the object used in the sample code

1. Object properties

Every Vissim-COM object has properties ('Property'). We can query the properties of the objects with the 'get' method. In case of the 'Simulation' object there is only one, it can be seen in the figure below.

```
Command Window
>> sim.get
SimulationSecond: 24.6667
```

9. Query of the 'Simulation' object with 'get' command

2. Object attributes

Objects have so-called attributes ('Attribute') as well. To reach them you must use the 'AttValue' method.

The attributes can be found in the Vissim Online Help via the Vissim GUI (click on Help\Online Help...).

The screenshot shows a software interface with a red header bar containing the text ">> Vissim - COM > ISimulation". Below the header, the title "ISimulation Attributes" is displayed. Underneath the title, there are two links: "Overview" and "Collapse All". A "Summary" section is expanded, showing a table with three columns: "Identifier", "Short name", and "Long name". The table lists various simulation attributes such as Comment, IsRunning, MesoSectsForMicroSim, NumCores, NumRuns, RandSeed, RandSeedIncr, RetroSync, SimBreakAt, SimMode, SimPeriod, SimRes, SimSec, SimSpeed, SimTmOfDay, and StartDate.

Identifier	Short name	Long name
Comment	Comment	Comment
IsRunning	IsRunning	Is running
MesoSectsForMicroSim	MesoSectsForMicroSim	Meso - sections for microscopic simulation
NumCores	NumCores	Number of cores
NumRuns	NumRuns	Number of runs
RandSeed	RandSeed	Random seed
RandSeedIncr	RandSeedIncr	Random seed increment
RetroSync	RetroSync	Retrospective synchronization
SimBreakAt	SimBreakAt	Simulation break at
SimMode	SimMode	Simulation mode
SimPeriod	SimPeriod	Simulation period
SimRes	SimRes	Simulation resolution
SimSec	SimSec	Simulation second
SimSpeed	SimSpeed	Simulation speed
SimTmOfDay	SimTmOfDay	Simulation time (time of day)
StartDate	StartDate	Start date

10. Part of the attribute table of the 'Simulation' object (PTV Online Help)

There are read-only and editable attributes. By clicking on the name of the identifier the 'Type' and 'Editable' fields show you whether the attribute is editable or not, and if it is whether you can edit its value during the simulation or not. For an example see the figure below.

SimRes	
Value type	unsigned int32
Editable	True
Simulation Behavior	EditableDuringSim
Type	Optional
Minimum	1
Maximum	20
Default value	10

SimPeriod	
Value type	durationInSeconds
Editable	True
Simulation Behavior	ReadOnlyDuringSim
Type	Optional
Minimum	1
Default value	3600

SimSec	
Value type	preciseDurationInSeconds
Editable	False
Simulation Behavior	ReadOnlyDuringSim
Type	Calculated
Minimum	0

11. Editable and not editable attributes of ‘Simulation’

Syntax of the usage of the ‘AttValue’ method in the case of readout (‘get’) and for change (‘set’) is as follows:

```
sim.get('AttValue', {'attribute'});
sim.set('AttValue', {'attribute'}, {adjustable value});
```

In connection with the figure above:

```
sim.get('AttValue', 'SimSec');           %(SimSec is read-only, so the ‘set’
                                         command is not allowed.)
```

Another example to set the length of the simulation in Matlab Script file:

```
period_time=3600;
sim.set('AttValue', 'SimPeriod', period_time);   %(You can edit it only outside the
                                                    simulation.)
sim.get('AttValue', 'SimPeriod')                 %(The answer will be 3600.)
```

As another example, we mention the ‘Simulation Resolution’ property. This represents how many times the Vissim traffic model runs in a second during the simulation. We can change it with the following code:

```
step_time=3;
sim.set('AttValue', 'SimRes', step_time);        %(The ‘SimRes’ attribute can only
                                                    be set at full simulation seconds)
sim.set('AttValue', 'SimRes')                    %(The answer will be 3.)
```

There is an alternate syntax for reading Vissim attributes which is entirely equivalent to the “get” method:

```
sim.AttValue({'attribute'});
```

An example is given below:

```
sim.AttValue('SimPeriod') ⇔ sim.get('AttValue', 'SimPeriod')
```

6. Running a simulation

Using Vissim there are three ways to run a simulation:

- ‘RunContinuous’: continuous running,
- ‘RunSingleStep’: running step-by-step, i.e. the time interval between steps will be simulated according to the ‘Simulation Resolution’ setting,
- ‘RunMulti’: multiple simulations in a row.

We point out the ‘RunSingleStep’ method since this way makes it easy to manipulate the simulation ‘online’, i.e. during the simulation run (for example changing the traffic demands continuously).

‘RunSingleStep’ is recommended to use with a ‘for’ loop. In the following example we run a simulation which shows the elapsed simulation time at each step (‘period_time’ and ‘step_time’ variables are defined previously).

```
for i=0:(period_time* step_time)
    sim.RunSingleStep;
    sim.get('AttValue', 'SimSec');
end
```

While using ‘RunSingleStep’, the ‘Simulation Speed’ setting has no effect on the running speed of the simulation. In this case, the simulation runs step by step according to the ‘for’ loop, by running each ‘time step’ on the maximum speed is possible. Therefore, using the above method the simulation speed can be controlled by Matlab ‘pause’ command (e.g. to slow down the simulation for visual observation). In the following example, a 500 ms long pause is inserted after each simulated time step:

```
for i=0:(period_time*step_time)
    sim.RunSingleStep;
    pause(0.5);
end
```

It must be noted that the ‘Snapshot’ functionality (for warm simulation start) has been totally removed from version 7 of Vissim. The last version was Vissim 5 where ‘SaveSnapshot’ and ‘LoadSnapshot’ methods were included. The official site of PTV reports that this functionality will be available in one of the future version of Vissim.

7. Traffic generation

Vissim-COM makes it possible to dynamically change traffic demands, which is very useful, for example in the following cases:

- to run several simulations with different traffic demands (possibly by ‘MultiRun’ method),
- to generate varying traffic demand by following the traffic changes of a day (during the simulation run).

First of all, the ‘Net’ object has to be created, which is located below the main object in the Vissim-COM hierarchy model (see figure below). This can be achieved through the main object ‘vis’ (already defined above):

```
vnet=vis.Net;
```

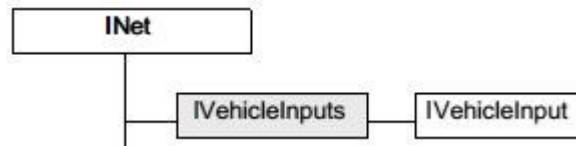

12. ‘VehicleInput’ object in the Vissim-COM hierarchy (on the basis of PTV, 2017)

Next the ‘VehicleInputs’ collection has to be created which contains all vehicle inputs (‘VehicleInput’), defined in the Vissim GUI:

```
vehins=vnet.VehicleInputs;
```

Via the ‘VehicleInputs’ collection any ‘VehicleInput’ object becomes accessible by using the ‘ItemByKey’ method, e.g.:

```
vehin_1=vehins.ItemByKey(1);
```

The given ‘VehicleInput’ object is easily editable through ‘AttValue’ method (by using the attributes in figure below).

>> [Vissim - COM](#) > [VehicleInput](#)

VehicleInput Attributes

[Overview](#) [Collapse All](#)

Summary

Identifier	Short name	Long name
Cont	Cont	Continued
LabPosRelPt	LabPosRelPt	Label position relative
LabPosRelWktPoint	LabPosRelWktPoint	WKT Label position relative
LabPosRelX	LabPosRelX	Label position relative (x)
LabPosRelY	LabPosRelY	Label position relative (y)
Link	Link	Link
Name	Name	Name
No	No	Number
ShowLabel	ShowLabel	Show label
VehComp	VehComp	Vehicle composition
VolType	VolType	Volume type
Volume	Volume	Volume

13. The attribute table of the 'VehicleInput' object (PTV Vissim Online Help)

An example for the modification of a traffic volume attribute in the first time interval of vehicle inputs:

```
vehin_1.set('AttValue', 'Volume(1)', 600);           %(in Volume(1) the '1' stands for the first
                                                    time interval)
```

8. Traffic signal control, detectors

Traffic light control can be programmed via COM interface as well. However, the previously mentioned VisVAP module (flow chart based programming) or Signal Controller API interface (on C++ language) can also be applied for traffic signal programming.

The traffic signal control within Vissim-COM object model is shown in the figure below.

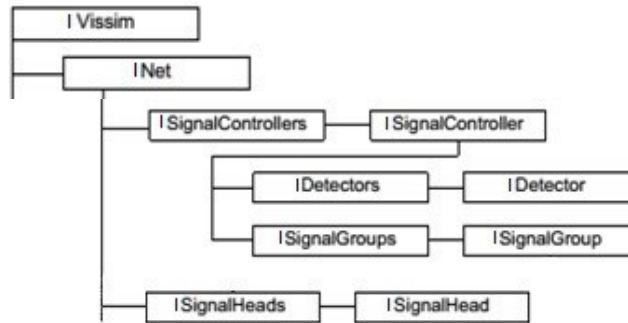

14. Components of traffic signal control within Vissim-COM object model (on the basis of PTV, 2017)

Now, a simple example is provided to demonstrate traffic signal control via Vissim-COM.

A simple signalized intersection is given (see the figure below), where two one-way roads (a main road and a side street) meet. There are two signal groups operating in the junction. By default, the main road is operated by a constant green time signal. At the same time, the signal group of the side road only gets green time when the loop detector is activated. This is the so-called demand-actuated traffic signaling. The system checks the loop detector's availability in every 20 seconds. The demand-actuated stage has 20 seconds.

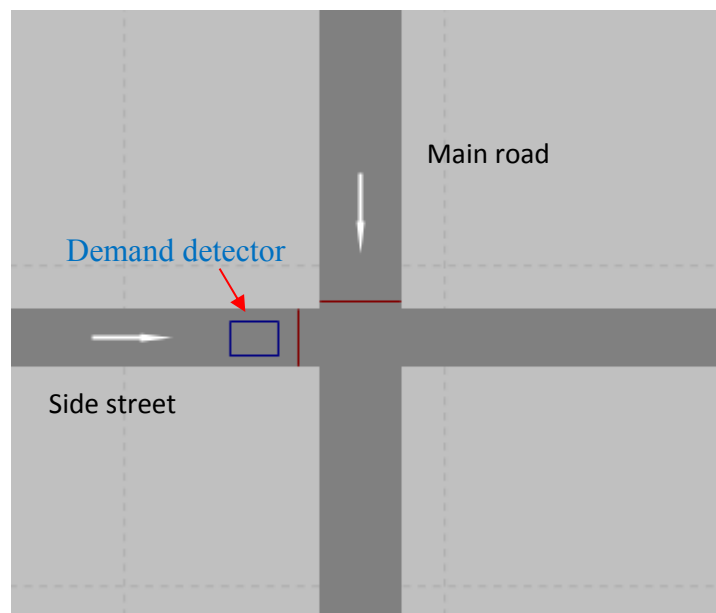

15. Simple intersection in Vissim with traffic demand actuated control

First you must create the necessary elements in the Vissim GUI:

- define signal control system in ‘Signal Control/Edit Controllers’ menu, by choosing ‘Fixed time’ controller (later it will be operated as a traffic-responsive controller from COM program);
- create signal groups (‘Signal Group’) with a given signal program (shown in the figure below);

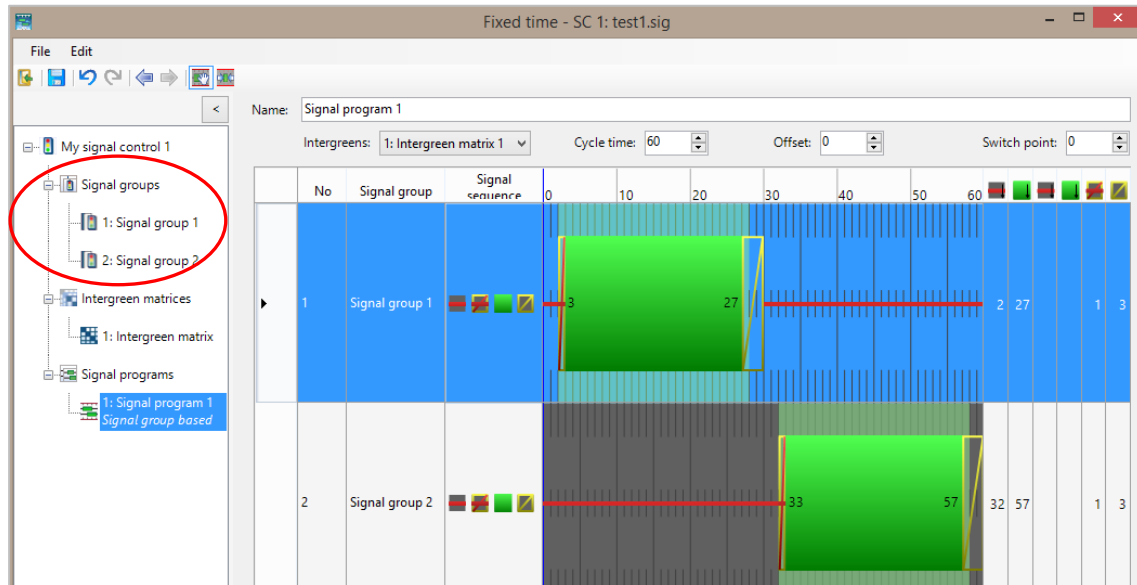

16. Create ‘Signal Group’ in Vissim GUI with signal plan

- locate signal heads (‘Signal Head’) on the main and side roads;
- locate demand detector on the side street (‘Detector’).

Then, the signal controller should be defined through Vissim-COM ‘SignalControllers’ collection:

```
scs=vnet.SignalControllers;
```

```
sc=scs.ItemByKey(1);           %(Signal Controller 1)
```

Create signal group objects through ‘SignalGroups’ collection:

```
sgs=sc.SGs;
```

```
sg_1=sgs.ItemByKey(1);        %(Signal Group 1)
```

```
sg_2=sgs.ItemByKey(2);        %(Signal Group 2)
```

Additionally, define a loop detector object for traffic demand sensing:

```
dets=sc.Detectors;
```

```
det_all=dets.GetAll();         %(All detectors are queried first)
```

```
det_1=det_all{1};             %(The first detector of the detectors)
```

The signals of the signal groups can be controlled by ‘State’ attribute of ‘SignalGroup’ object with the correct codes (see figure below), e.g. setting red signal for State 1:

```
sg_1.set('AttValue', 'State', 1);
```

>> Vissim - COM > SignalizationState Enumeration

SignalizationState Enumeration

Collapse All

Members

Member	Value	Summary
SignalizationStateAlternatingRedGreen	10	
SignalizationStateAmber	4	
SignalizationStateFlashingAmber	7	
SignalizationStateFlashingGreen	9	
SignalizationStateFlashingRed	8	
SignalizationStateGreen	3	
SignalizationStateGreenAmber	11	
SignalizationStateOff	5	
SignalizationStateRed	1	
SignalizationStateRedAmber	2	
SignalizationStateUndefined	6	

Copyright © 2015 PTV AG PTV VISSIM

17. 'State' attribute codes of 'SignalGroup' (PTV Vissim Online Help)

Status of the loop detector is queried also through the 'AttValue' method by various attributes e.g.:

```
det_1.get('AttValue', 'Detection');
det_1.get('AttValue', 'Impulse');
det_1.get('AttValue', 'Occup');           %(Occupancy)
det_1.get('AttValue', 'Presence');
```

In addition to the above, the traffic-responsive logic is created by 'rem' command of Matlab (which gives back the remainder after a division of two numbers):

```
for i=0:( period_time*step_time)
    sim.RunSingleStep;
    if rem(i/step_time,20)==0           % verifying at every 20 seconds
        demand=det_1.get('AttValue', 'Presence'); % verifying detector occupancy: 0/1
        if demand==1                   % demand -> demand-actuated stage
            sg_1.set('AttValue','State',1); % main road red (1)
            sg_2.set('AttValue','State',3); % side street green (3)
        else                             % no demand -> main road is green
```

If you find this manual useful, please, cite this paper: <https://doi.org/10.3311/pp.ci.2012-1.05>

```
    sg_1.set('AttValue', 'State', 3);  
    sg_2.set('AttValue', 'State', 1);  
end  
end  
end
```

So that it is easier to understand the logic, in the example above we neglected the intergreen times between the two phases and we did not use transition signals (red-amber, amber). To create them, further programming is necessary.

9. Evaluation while the program is running

An important advantage of the Vissim-COM is the possibility of evaluation while the program is running. The following example is shown from the numerous evaluation options. We consider the evaluation of data collection points through 'DataCollectionMeasurements'.

Data Collection Points can be used effectively with the Vissim GUI. They can be positioned on any link in the road network, furthermore they are suitable for measuring several parameters in the given cross section (e.g. acceleration, number of vehicles, occupancy).

You can reach the measurements of the given data collection point through the 'Data Collection Measurements' field and the 'ItemByKey' method:

```
datapoints=vnet.DataCollectionMeasurements;  
datapoint1=datapoints.ItemByKey(1);
```

For the evaluation of the data collection points via Vissim-COM (even while the program is running) the 'IDataCollectionMeasurement' attributes can be used with the appropriate parameters (see figure below).

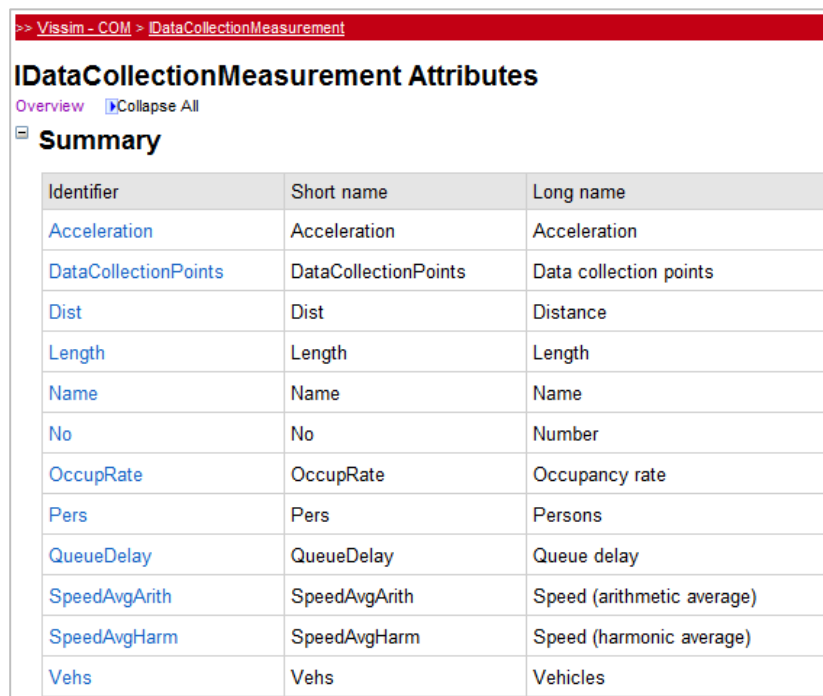

The screenshot shows a window titled '>> Vissim - COM > IDataCollectionMeasurement'. Below the title bar, the text 'IDataCollectionMeasurement Attributes' is displayed. There are two tabs: 'Overview' (selected) and 'Collapse All'. A 'Summary' section is expanded, showing a table with three columns: Identifier, Short name, and Long name. The table lists various attributes such as Acceleration, DataCollectionPoints, Dist, Length, Name, No, OccupRate, Pers, QueueDelay, SpeedAvgArith, SpeedAvgHarm, and Vehs.

Identifier	Short name	Long name
Acceleration	Acceleration	Acceleration
DataCollectionPoints	DataCollectionPoints	Data collection points
Dist	Dist	Distance
Length	Length	Length
Name	Name	Name
No	No	Number
OccupRate	OccupRate	Occupancy rate
Pers	Pers	Persons
QueueDelay	QueueDelay	Queue delay
SpeedAvgArith	SpeedAvgArith	Speed (arithmetic average)
SpeedAvgHarm	SpeedAvgHarm	Speed (harmonic average)
Vehs	Vehs	Vehicles

18. The 'IDataCollectionMeasurement' attributes that can be queried (PTV Vissim Online Help)

The following code is an example for it:

```
datapoint1.get('AttValue', 'Speed(19, 2, All)');
```

where the elements in brackets are:

- parameter to query;
- the number of the simulation run (now: 19);
- the number of the time interval (now: 2);
- Vehicle Class, where 'All' value includes all vehicle classes.

Result attributes can be saved for multiple simulation runs, time intervals and different vehicle classes. It is possible to access all saved result values by COM. To access these values three sub attributes are required given in the figure below. You can replace the constant (19 and 2 in the example above) sub-attributes with periodic inputs.

Sub attribute #	Possible Input	Description
1	SimulationRun	1, 2, 3, ... or Current number according to the attribute No of simulation runs (see Simulation Runs list) or Current for the simulation run currently running
	Avg, StdDev, Min, Max	aggregated value of all simulations runs
2	TimeInterval	1, 2, 3 ... or Last index of one specific time interval (the index for time intervals always starts at 1 which refers to the first time interval) or Last to reference to the last completed time interval.
	Avg, StdDev, Min, Max	aggregated value of all time intervals of one simulation
	Total	sum over all time intervals of one simulation
3	VehicleClass	10, 20, ... or All one or more vehicle class numbers (according to the attribute No of Vehicle Classes) or All. Data is shown only for the vehicle classes defined here.

19. Sub-attributes' table (PTV, 2017)

However, generally sub-attributes 'Current' and 'Last' (see their meaning in Fig. 19.) are suggested to be used only, e.g. `datapoint1.get('AttValue', 'Speed(Current, Last, All)');`

An indispensable condition of measurement by data collection points is (even by using Vissim-COM) that the option of 'Data Collections/Collect data' is flagged (and well configured) in 'Evaluation/Configuration.../Result Attributes' menu in the Vissim GUI. The time interval of data collections is also important. You will get an average value for the measured factors in each time interval. The shorter the interval is the more sophisticated results you get. The adjustment and the evaluation results are depicted in the figure below.

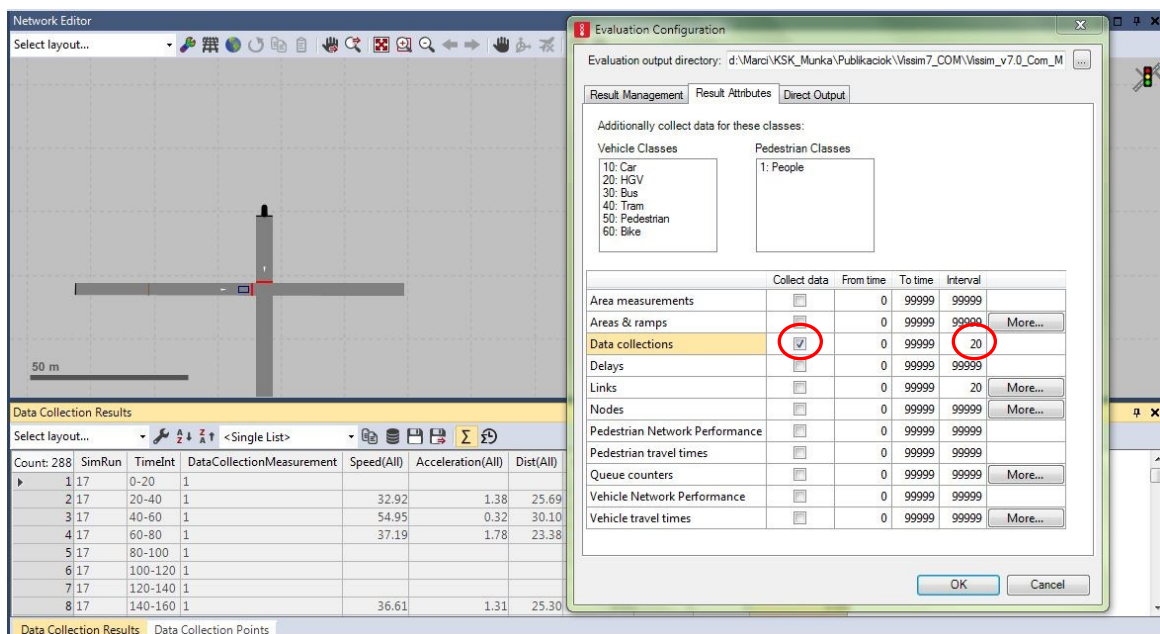

20. Evaluation configuration and evaluation results

10. A complete sample code for Vissim-COM programming

A sample code for Vissim-COM programming (written in Matlab) is presented below based on the examples introduced in this manual.

```
%% Vissim-COM programming - example code %%
clear all;
close all;
clc; % Clears the command window
%% Create Vissim-COM server
vis=actxserver('VISSIM.vissim.900');
%% Loading the traffic network
access_path=pwd;
vis.LoadNet([access_path '\test.inpx']);
vis.LoadLayout([access_path '\test.layx']);
%% Simulation settings
sim=vis.Simulation;
period_time=3600;
sim.set('AttValue', 'SimPeriod', period_time);
step_time=3;
sim.set('AttValue', 'SimRes', step_time);
%% Define the network object
vnet=vis.Net;
%% Setting the traffic demands of the network
vehins=vnet.VehicleInputs;
vehin_1=vehins.ItemByKey(1);
vehin_1.set('AttValue', 'Volume(1)', 1500); % main road
vehin_2=vehins.ItemByKey(2);
vehin_2.set('AttValue', 'Volume(1)', 100); % side street
%% The objects of the traffic signal control
scs=vnet.SignalControllers;
sc=scs.ItemByKey(1);
sgs=sc.SGs; % SGs=SignalGroups
sg_1=sgs.ItemByKey(1);
sg_2=sgs.ItemByKey(2);
dets=sc.Detectors;
det_all=dets.GetAll;
det_1=det_all{1};
%% Access to DataCollectionPoint object
datapoints=vnet.DataCollectionMeasurements;
datapoint1=datapoints.ItemByKey(1);
%% Access to Link object
links=vnet.Links;
link_1=links.ItemByKey(1);
%% Running the simulation
verify=20; % verifying at every 20 seconds
%Evaluation\Configuration...\Interval in the Vissim GUI
for i=0:(period_time*step_time)
    sim.RunSingleStep;
    if rem(i/step_time, verify)==0 % verifying at every 20 seconds
        demand=det_1.get('AttValue', 'Presence'); %get detector occupancy:0/1
        if demand==1 % demand -> demand-actuated stage
            sg_1.set('AttValue', 'State', 1); % main road red (1)
            sg_2.set('AttValue', 'State', 3); % side street green (3)
        else % no demand on loop -> main road's signal is green
            sg_1.set('AttValue', 'State', 3);
            sg_2.set('AttValue', 'State', 1);
        end
        % Query the avg. speed and vehicle number at the end of each eval. interval:
        datapoint1.get('AttValue', 'Vehs(Current, Last, All)')
        datapoint1.get('AttValue', 'Speed(Current, Last, All)')
    end
end
%% Delete Vissim-COM server (also closes the Vissim GUI)
vis.release;
disp('The end')
```

If you find this manual useful, please, cite this paper: <https://doi.org/10.3311/pp.ci.2012-1.05>

11. Bibliography

Box D. Essential COM, Addison-Wesley, ISBN 0-201-63446-5, 1998

PTV, Introduction to the PTV Vissim 9 COM API, PTV Planung Transport Verkehr AG, Germany, 2017

Wiedemann R. Simulation des Straßenverkehrsflusses Schriftenreihe des Instituts für Verkehrswesen der Universität Karlsruhe, Heft 8, 1974