

PROCEEDINGS OF THE INTERNATIONAL CONFERENCE ON METAL STRUCTURES – ICMS-03
MISKOLC, HUNGARY, APRIL 3-5, 2003

METAL STRUCTURES

Design, Fabrication, Economy

Edited by

Károly Jármai
University of Miskolc, Hungary

József Farkas
University of Miskolc, Hungary

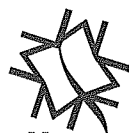

Millpress

MILLPRESS ROTTERDAM NETHERLANDS 2003

Cover design: Millpress

All rights reserved.

This publication may not be reproduced in whole or in part, stored in a retrieval system or transmitted in any form or by any means without permission from the publisher, Millpress Science Publishers.
info@millpress.com

Published and distributed by Millpress Science Publishers, P.O. Box 84118, 3009 CC Rotterdam, Netherlands
Tel.: +31 (0) 10 421 26 97; Fax: +31 (0) 10 209 45 27; www.millpress.com

ISBN 90 77017 75 5
© 2003 Millpress Rotterdam
Printed in the Netherlands

Minimum cost design of uniaxially compressed plates with welded trapezoidal stiffeners considering a reliability constraint

K. Jármai & J. Farkas
University of Miskolc, Hungary

L.C. Simões
University of Coimbra, Portugal

Keywords: structural optimization, reliability, welded structures, stiffened plates, buckling of compressed plates, distortion prevention

ABSTRACT: The cost function to be minimized expresses the material and fabrication costs. Design constraints are as follows: global buckling of the uniaxially compressed longitudinally stiffened plate, local buckling of plate and stiffener elements, torsional buckling of open-section ribs, limitation of the thickness of cold-formed trapezoidal stiffeners, limitation of the distortion caused by shrinkage of welds. Reliability of the global buckling constraint has been taken into account due to a given deviation at the different parameters. The optimum dimensions and number of stiffeners are determined by a mathematical programming method. The cost differences between the best and worst solutions are 5-25%, so the optimization results in significant cost savings. The probability of failure at the optimum is $p_f = 0.00591$.

1 INTRODUCTION

Uncertainties are unavoidable in the design. The engineering analysis should contain tools for the evaluation of uncertainties. Many phenomena or process of concern to engineering contain randomness; i.e. the outcomes are unpredictable.

Traditionally, the reliability of engineering systems is achieved through the use of factors or margins of safety and adopting conservative assumptions in the process of design.

Welded stiffened plates are widely used in various load-carrying structures, e.g. ships, bridges, bunkers, tank roofs, offshore structures, vehicles, etc. They are subject to various loadings, e.g. compression, bending, shear or combined load. The shape of plates can be square rectangular, circular, trapezoidal, etc. They can be stiffened in one or two directions with stiffeners of flat, L, trapezoidal or other shape.

From these structural versions we select here rectangular plates uniaxially compressed and stiffened in the direction of the compressive load. It should be mentioned that we have worked out minimum cost design procedure of square and rectangular orthogonally stiffened and cellular plates loaded in bending (Farkas & Jármai 1997), uniaxially compressed rectangular plates with flat and L-stiffeners (Farkas & Jármai 1998a), welded bridge

decks with open- and closed-section stiffeners (Jármai et al. 1997, Jármai et al. 1998).

It is well known that the instability phenomena are significantly affected by initial imperfections and residual welding stresses. For instance, it has been shown that a compression strut designed using the classical Euler method can be 30% unsafe (Farkas & Jármai 1997). Thus, these effects should be considered in all stability calculations.

In (Farkas & Jármai 1998a) we have used the design rules of API (1987). Mikami and Niwa (1996), (Discussion of Mikami and Niwa (1996) by Bedair 1997) have recently developed a calculation method for orthogonally stiffened uniaxially compressed rectangular plates taking into account the initial imperfections and residual welding stresses. Their formulae are based on experimental results.

The aim of the present study is to apply the Mikami-Niwa method for the optimum design and comparison of uniaxially compressed plates stiffened with ribs (Fig.1). In the minimum cost design the characteristics of the optimal structural version are sought which minimize the cost function and fulfil the design constraints. In recent years we have developed a cost function containing the material and fabrication costs (Farkas & Jármai 1997, Jármai & Farkas 1999) and we have included in the design constraints also the quality requirement, which pre-scribes the allowable deformation caused by residual welding distortions (Farkas & Jármai 1998b).

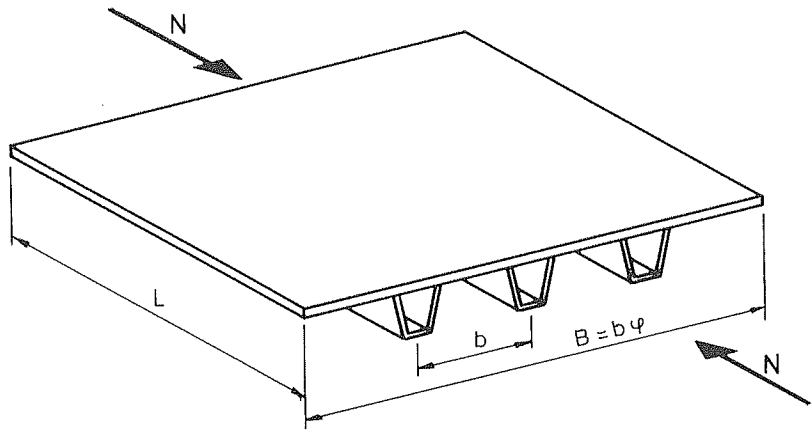

Figure 1. A uniaxially compressed longitudinally stiffened plate

These three important aspects in the design of welded structures are included in the present study as well, to have a realistic basis for comparison. First the general formulae for the cost function and design constraints are treated, then the special calculation of trapezoidal stiffeners is described and a reliability constraint is built into the system. A numerical example illustrates the differences among the structural versions.

2 COST FUNCTION

The objective function to be minimized is defined as the sum of material and fabrication costs

$$K = K_m + K_f = k_m \rho V + k_f \sum T_i, \quad (1)$$

or in another form

$$\frac{K}{k_m} = \rho V + \frac{k_f}{k_m} (T_1 + T_2 + T_3), \quad (2)$$

where ρ is the material density, V is the volume of the structure, K_m and K_f as well as k_m and k_f are the material and fabrication costs as well as cost factors, respectively, T_i are the fabrication times as follows:

time for preparation, tacking and assembly

$$T_1 = \Theta_d \sqrt{\kappa \rho V}, \quad (3)$$

where Θ_d is a difficulty factor expressing the complexity of the welded structure, κ is the number of structural parts to be assembled; T_2 is time of welding, and T_3 is time of additional works such as changing of electrode, deslagging and chipping. $T_3 \approx 0.3T_2$, thus,

$$T_2 + T_3 = 1.3 \sum C_{2i} a_{wi}^n L_{wi}, \quad (4)$$

where L_{wi} is the length of welds, the values of $C_{2i} a_{wi}^n$ can be obtained from formulae or diagrams constructed using the COSTCOMP software (Bodt 1990), a_w is the weld dimension.

3 DESIGN CONSTRAINTS

3.1 Global buckling of the stiffened plate

According to Mikami and Niwa the effect of initial imperfections and residual welding stresses is considered by defining buckling curves for a reduced slenderness

$$\lambda = (f_y / \sigma_{cr})^{1/2}, \quad (5)$$

where σ_{cr} is the classical critical buckling stress, which does not contain the above mentioned effects, f_y is the yield stress.

The classical critical buckling stress for a uniaxially compressed longitudinally stiffened plate (Fig.1) is

$$\sigma_{cr} = \frac{\pi^2 D}{hB^2} \left(\frac{1 + \gamma_s}{\alpha_R^2} + 2 + \alpha_R^2 \right)$$

for $\alpha_R = L/B < \alpha_{R0} = (1 + \gamma_s)^{1/4}$, (6)

$$\sigma_{cr} = \frac{2\pi^2 D}{hB^2} \left[1 + (1 + \gamma_s)^{1/2} \right]$$

for $\alpha_R \geq \alpha_{R0}$, (7)

where, with $\nu = 0.3$.

$$D = \frac{Et_F^3}{12(1 - \nu^2)} = \frac{Et_F^3}{10.92},$$
 (8)

$$h = t_F + \frac{A_s}{bt_F}; \quad b = \frac{B}{\varphi},$$
 (9)

A_s is the cross-sectional area of a stiffener, $\varphi - 1$ is the number of stiffeners,

$$\gamma_s = \frac{EI_s}{bD},$$
 (10)

I_s is the moment of inertia of a stiffener about the ξ axis (Fig. 4).

Knowing the reduced slenderness (Equation 5) the actual global buckling stress can be calculated as follows:

$$\sigma_U / f_y = 1 \quad \text{for} \quad \lambda \leq 0.3 \quad (11a)$$

$$\sigma_U / f_y = 1 - 0.63(\lambda - 0.3) \quad \text{for} \quad 0.3 \leq \lambda \leq 1 \quad (11b)$$

$$\sigma_U / f_y = 1 / (0.8 + \lambda^2) \quad \text{for} \quad \lambda > 1 \quad (11c)$$

This buckling curve is shown in Figure 2. It can be seen that the used buckling curve contains the effect of initial imperfections ($a_0 \neq 0$) and residual welding stresses ($\sigma_R \neq 0$), therefore it gives much lower values than the classical critical buckling curve, which neglects these effects.

The global buckling constraint is defined by

$$\frac{N}{A} \leq \sigma_U^* = \sigma_U \frac{\rho_p + \delta_s}{1 + \delta_s}$$
 (12)

where

$$A = Bt_F + (\varphi - 1)A_s$$
 (13)

$$\text{and} \quad \delta_s = \frac{A_s}{bt_F}$$
 (14)

ρ_p can be determined considering the single panel buckling of the base plate parts between the stiffeners. The factor $(\rho_p + \delta_s)/(1 + \delta_s)$ expresses the effect of the effective width of the base plate parts.

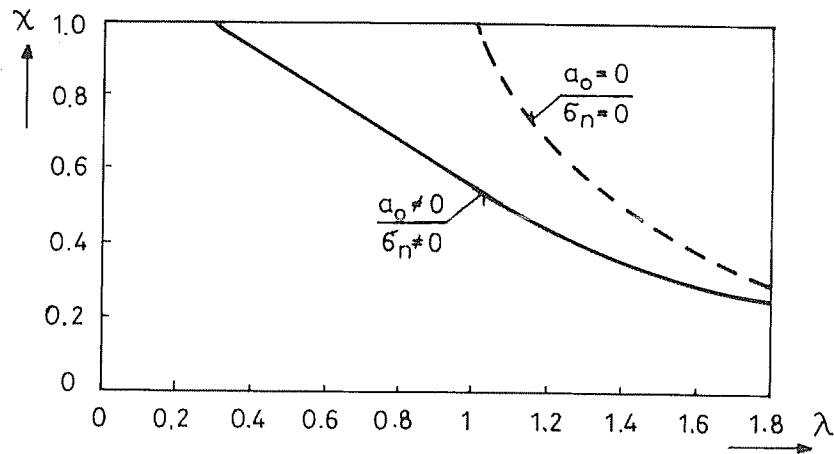

Figure 2. Global buckling curve considering the effect of initial imperfections ($a_0 \neq 0$) and residual welding stresses ($\sigma_R \neq 0$)

3.2 Single panel buckling

This constraint eliminates the local buckling of the base plate parts between the stiffeners. From the classical buckling formula for a simply supported uniformly compressed in one direction

$$\sigma_{crp} = \frac{4\pi^2 E}{10.92} \left(\frac{t_F}{b} \right)^2, \quad (15)$$

the reduced slenderness is

$$\lambda_p = \left(\frac{4\pi^2 E}{10.92 f_y} \right)^{1/2} \frac{b}{t_F} = \frac{b}{t_F} \frac{1}{56.8 \varepsilon};$$

$$\varepsilon = \left(\frac{235}{f_y} \right)^{1/2}, \quad (16)$$

and the actual local buckling stress considering the initial imperfections and residual welding stresses is

$$\sigma_{UP} / f_y = 1 \quad \text{for} \quad \lambda_p \leq 0.526 \quad (17a)$$

$$\frac{\sigma_{UP}}{f_y} = \left(\frac{0.526}{\lambda_p} \right)^{0.7} \quad \text{for} \quad \lambda_p \geq 0.526 \quad (17b)$$

This buckling curve is shown in Figure 3. Then the factor ρ_p is as follows:

$$\rho_p = 1 \quad \text{if} \quad \sigma_{UP} > \sigma_U \quad (18a)$$

$$\rho_p = \sigma_{UP} / f_y \quad \text{if} \quad \sigma_{UP} \leq \sigma_U \quad (18b)$$

3.3 Local and torsional buckling of stiffeners

These instability phenomena depend on the shape of stiffeners and will be treated separately for the trapezoidal stiffeners.

The torsional buckling constraint for open section stiffeners is

$$N / A \leq \sigma_{UT}. \quad (19)$$

The classical torsional buckling stress is (Farkas & Jármai 1997)

$$\sigma_{crT} = \frac{GI_T}{I_p} + \frac{EI_\omega}{L^2 I_p} \quad (20)$$

where $G = E/2.6$ is the shear modulus, I_T is the torsional moment of inertia, I_p is the polar moment of inertia and I_ω is the warping constant. The actual torsional buckling stress can be calculated in the function of the reduced slenderness

$$\lambda_T = (f_y / \sigma_{crT})^{1/2}, \quad (21)$$

$$\sigma_{UT} / f_y = 1 \quad \text{for} \quad \lambda_T \leq 0.45, \quad (22a)$$

$$\frac{\sigma_{UT}}{f_y} = 1 - 0.53(\lambda_T - 0.45) \quad \text{for} \quad 0.3 \leq \lambda_T \leq 1.41, \quad (22b)$$

$$\frac{\sigma_{UT}}{f_y} = \frac{1}{\lambda_T^2} \quad \text{for} \quad \lambda_T \geq 1.41. \quad (22c)$$

This buckling curve is shown in Figure 3.

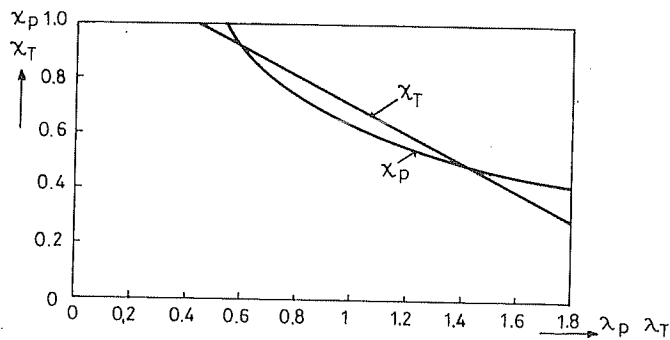

Figure 3. Limiting curves for local plate buckling (χ_p) and torsional buckling of open section ribs (χ_T)

It should be noted that the interaction of above treated instability phenomena (coupled instability) is not considered here, since it has been shown (Farkas & Jármai 1997) that this interaction can be neglected when the effect of initial imperfections and residual welding stresses is taken into account for individual buckling modes.

3.4 Distortion constraint

In order to assure the quality of this type of welded structures large deflections due to weld shrinkage should be avoided. It has been shown that the curvature of a beam-like structure due to shrinkage of longitudinal welds can be calculated by relatively simple formulae (Farkas & Jármai 1998b). The allowable residual deformations f_0 are prescribed by design rules. For compression struts Eurocode 3 (EC3, 1992) prescribes $f_0 = L/1000$, thus the distortion constraint is defined as

$$f_{\max} = CL^2 / 8 \leq f_0 = L / 1000, \quad (23)$$

where the curvature is for steels

$$C = 0.844 \times 10^{-3} Q_T y_T / I_x, \quad (24)$$

Q_T is the heat input, y_T is the weld eccentricity

$$y_T = y_G - t_F / 2, \quad (25)$$

I_x is the moment of inertia of the cross-section containing a stiffener and the base plate strip of width b .

3.5 Local buckling of trapezoidal stiffeners (Figure 4.)

$$A_S = (a_1 + 2a_2)t_3; \quad (26)$$

$$I_S = a_1 h_3^2 t_3 + \frac{2}{3} a_2^3 t_3 \sin^2 \alpha.$$

According to (Stahlbau 1985) $a_1 = 90$, $a_3 = 300$ mm, thus

$$h_3 = (a_2^2 - 105^2)^{1/2}; \quad \sin^2 \alpha = 1 - \left(\frac{105}{a_2}\right)^2 \quad (27)$$

$$y_G = \frac{a_1 t_3 (h_3 + t_F / 2) + 2a_2 t_3 (h_3 + t_F) / 2}{bt_F + A_S} \quad (28)$$

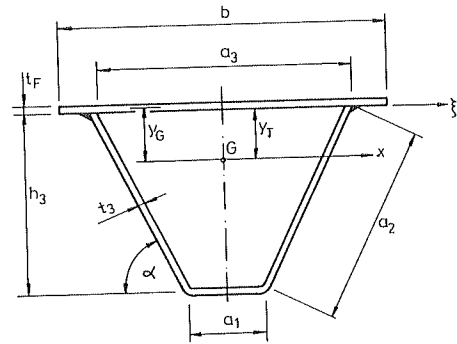

Figure 4. Dimensions of a trapezoidal stiffener

$$I_x = \frac{bt_F^3}{12} + bt_F y_G^2 + a_1 t_3 \left(h_3 + \frac{t_F}{2} - y_G \right)^2 + \frac{1}{6} a_2^3 t_3 \sin^2 \alpha + 2a_2 t_3 \left(\frac{h_3 + t_F}{2} - y_G \right)^2 \quad (29)$$

$$a_W = 0.5t_3, \quad \text{but } a_{W\min} = 4 \text{ mm.}$$

Local buckling of a trapezoidal stiffener is defined as

$$a_2 / t_3 \leq 38\epsilon \quad (30)$$

This constraint is treated as active.

The single panel buckling constraint is given by Equations 15-17, but, in the case of trapezoidal stiffeners, instead of b the larger value of $a_3 = 300$ and $b_3 = b - 300$ should be considered.

Furthermore, the heat input for a stiffener is

$$Q_T = 2x59.5a_W^2 \quad (31)$$

3.6 Reliability constraint

The global buckling constraint is usually active, that is why we use reliability aspect on it. Assume that the variables are uncorrelated (Ang and Tang 1975). Suppose an N compression force, a σ_U^* ultimate stress for global buckling and an A cross section area. So the global buckling constraint looks like

$$\frac{N}{A} \leq \sigma_U^* \quad (32)$$

The performance function $g(x) = \sigma_U^* A - N \geq 0$ is nonlinear, the evaluation of the exact probability of safety or failure will generally be involved. As given in Ang and Tang (1975) the evaluation of the exact probability of safety will involve the iteration of the joint probability density function over the nonlinear region. According to (Schueller 1987) on the failure

surface the minimum distance to the origin of the reduced variants is the most probable failure point.

Choose Coefficient Of Variations for the three parameters

$$COV_N = 0.1, COV_\sigma = 0.2, COV_A = 0.05. \quad (33)$$

Determine the reliability of the global buckling. The corresponding Standard Deviations are

$$\begin{aligned} SD_N &= COV_N * N, \quad SD_\sigma = COV_\sigma * \sigma_U^*, \\ SD_N &= COV_N * N. \end{aligned} \quad (34)$$

The distance from the minimum tangent plane to the origin of the reduced variants is the appropriate reliability index, which may be used to represent the measure of reliability.

In this case the partial derivatives are as follows

$$\left(\frac{\partial g}{\partial N}\right) = -SD_N \quad (35)$$

$$\left(\frac{\partial g}{\partial \sigma}\right) = SD_\sigma * A \quad (36)$$

$$\left(\frac{\partial g}{\partial A}\right) = SD_A * \sigma_U^* \quad (37)$$

For the first iteration assume $N^* = N$, $\sigma^* = \sigma_U^*$ and $A^* = A$.

The most probable failure point is

$$x_i^* = -DC_i^* \beta \quad (39)$$

where the Direction Cosines are as follows

$$DC_i^* = \frac{\left(\frac{\partial g}{\partial x_i}\right)}{\sqrt{\sum_i \left(\frac{\partial g}{\partial x_i}\right)^2}} \quad (40)$$

$$DC_N = DC_1^*, \quad DC_\sigma = DC_2^*, \quad DC_A = DC_3^*. \quad (41)$$

If the partial derivatives have been evaluated than

$$x_i^* = SD_i x_i^* + MV_{xi} = MV_{xi} - DC_i^* SD_i \beta, \quad (42)$$

where MV_{xi} are the Main Values, β is the safety index.

The components of the failure point are

$$x_1^* = N^* = MV_{x1} - DC_1^* SD_1 \beta, \quad (43)$$

$$x_2^* = \sigma_U^* = MV_{x2} - DC_2^* SD_2 \beta, \quad (44)$$

$$x_3^* = A^* = MV_{x3} - DC_3^* SD_3 \beta. \quad (45)$$

Substituting these into the limit-state equation, $g(x) = \sigma_U^* A - N \geq 0$, yields a quadratic equation for the safety index β , from which we obtain the first iteration for β .

The revised failure point then can be calculated by Equations (43-45). Repeating the procedure for subsequent iterations, when the values of β are close in the iterations, the assumed failure point and the safety index can be calculated.

Therefore the underlying probability of failure is

$$p_r = 1 - \Phi(\beta), \quad (46)$$

where $\Phi(\beta)$ is the standard normal probability

$$\Phi(\beta) = \frac{1}{\sqrt{2\pi}} \int_{-\infty}^{\beta} \exp\left(-\frac{1}{2}\xi^2\right) d\xi \quad (47)$$

Table of values of standard normal probability can be found in Ang and Tang (1975).

We have used a curve-fitting software to determine the values of $\Phi(\beta)$ (Fig. 5). Logistic model was chosen:

$$y = \frac{a}{1 + be^{-cx}} \quad (48)$$

Coefficient data are as follows:

$$\begin{aligned} a &= 1.0061396 \\ b &= 1.0263861 \\ c &= 1.6829595 \end{aligned}$$

The limits for the probability of failure were

$$0.0061 > p_f > 0.0.$$

We consider this constraint as a reliability constraint. For a designer the range of $p_f = 10^{-3}$ - 10^{-5} is applicable.

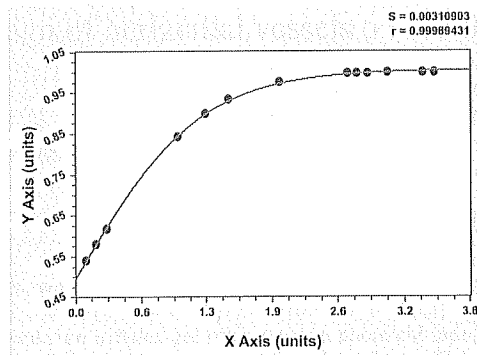

Figure 5. Curvefit for the standard normal probability.

Table 1. Optimum dimensions in mm of compressed plates with trapezoidal stiffeners

k_f/k_m (kg/min)	φ	t_F	t_3	K/k_m (kg)
0	16	11	5	2384
1	12	13	5	3407
	5	20	8	4454
	6	18	7	4275
	7	17	7	4377
2	8	17	5	4255
	9	15	6	4329
	10	15	5	4320
	11	14	5	4346
	12	13	5	4368
	13	13	5	4559
	14	12	5	4576

4 NUMERICAL EXAMPLE

Given data: $B = 6000$ mm, $L = 3000$ mm, $N = 1.974 \times 10^7$ N, $f_y = 235$ MPa, $E = 2.1 \times 10^5$ MPa, $G = E/2.6$, $\rho = 7.85 \times 10^{-6}$ kg/mm³, $\Theta_d = 3$.

The variables are as follows: φ, t_F as well t_3 for thickness of trapezoidal stiffeners.

The optima are computed using the Rosenbrock's Hillelimb mathematical programming method complemented by the final search for discrete rounded values (Farkas & Jármai 1997). The results are summarized in Table 1. The minimum costs for $k_f/k_m = 0, 1$ and 2 are denoted by bold numbers.

It can be seen that, in the regions of φ the cost differences between the best and worst versions are 7% for trapezoidal stiffeners, so it is necessary to optimize the number of stiffeners. The best solution $\varphi=8$, $t_F=17$, $t_3=5$, the probability of failure is $p_f = 0.00591$.

The main advantage of trapezoidal stiffeners is the large torsional stiffness. The material cost for the optimum version with trapezoidal stiffeners is 2789

kg, thus, the fabrication cost is $(4255-2789)/4255 \times 100 = 34\%$ of the total cost, this amount affects the optimum number of stiffeners for various fabrication cost factors.

5 CONCLUSIONS

Cost comparisons of structural versions obtained for a given numerical example by minimum cost design show the following:

(a) The cost difference between the best and worst solutions in the investigated region of stiffeners' number is significant, which emphasizes the necessity of optimization.

(b) The active constraints are as follows: the global buckling of stiffened plate, the torsional buckling of open-section ribs and the reliability constraint. Due to the discrete values, they are not at the limits close to them. Distortion constraint in this case is passive, since the weld length is relatively small.

ACKNOWLEDGEMENTS

The research work was supported by the Hungarian Scientific Research Foundation grants OTKA T38-058 and T37941 and the Fund for the Development of Higher Education FKFP 8/2000 project. The project was also supported by the Hungarian-Portuguese Intergovernmental S&T Co-operation program. The Hungarian partner is the Ministry of Education, R&D Deputy Undersecretary of State, the Portuguese partner is the Portuguese Ministry of Universities and Science.

REFERENCES

- American Petroleum Institute API *Bulletin on design of flat plate structures*. 1987. Bulletin 2V. Washington.
- Ang, A.H.S., Tang, W.H. 1975. *Probability concepts in engineering, Planning and design*, Volume I. John Wiley & Sons, New York, 408 p.*
- Bodt, H.J.M. 1990. *The global approach to welding costs*. The Netherlands Institute of Welding. The Hague.
- DAST (Deutscher Ausschuss für Stahlbau) Richtlinie 016. 1986, *Bemessung und konstruktive Gestaltung von Tragwerken aus dünnwandigen kaltgeformten Bauteilen*. Köln.
- Discussion of Mikami, I., Niwa, K. (1996) by Bedair, O. and authors' closure (1997) *J.Struct.Engng* 123 No.8.1116-1119.
- Eurocode 3. *Design of steel structures* 1992. Part 1.1. General rules and rules for buildings. European Prestandard ENV 1993-1-1. CEN European Committee for Standardisation, Brussels.
- Farkas, J., Jármai, K. 1997. *Analysis and optimum design of metal structures*. Balkema, Rotterdam-Brookfield.
- Farkas, J., Jármai, K. 1998a. Economic design of welded steel structures. *J. Constructional Steel Research* 46Nos.1-3. 35-36. Full paper on CD-ROM. Paper No.142.
- Farkas, J., Jármai, K. 1998b. Analysis of some methods for reducing beam curvatures due to weld shrinkage. *Welding in the World* 41No.4. 385-398.
- Jármai, K., Farkas, J. 1999. Cost calculation and optimization of welded steel structures. *J. Construct.Steel Res.* 50No.2. 115-135.
- Jármai, K., Farkas, J., Horikawa, K. 1998. Economic design of steel bridge decks. *Welding in the World* 41No.1. 49-59.
- Jármai, K., Horikawa, K., Farkas, J. 1997. Economic design of steel bridge decks with open ribs. *Transactions of JWRI (Joining and Welding Research Institute Osaka University)* 26No.1 147-161.
- Mikami, I., Niwa, K. 1996. Ultimate compressive strength of orthogonally stiffened steel plates. *J. Structural Engineering* ASCE 122 No.6. 674-682.
- Schueller, G.I. 1987. Basic Principles of Probability, Stochastic Processes and Reliability Methods, in: *Stochastic Methods in Structural Dynamics*, G.I. Schueller and M. Shinozuka (Eds.), Martinus Nijhoff Publ., Dordrecht / Boston / Lancaster, pp. 1-80.
- Stahlbau Handbuch* Band 2. 1985. Köln, Stahlbau-Verlag.